

# Service Manual

## VRV II<sup>®</sup>

### R-410A Heat Pump 50Hz



Большая библиотека технической документации

<https://splitsystema48.ru/instrukcii-po-ekspluatácii-kondicionerov.html>

каталоги, инструкции, сервисные мануалы, схемы.

# VRV<sup>®</sup> II R410A Heat Pump 50Hz

1. Introduction .....	vi
1.1 Safety Cautions .....	vi
1.2 PREFACE .....	x
Part 1 General Information .....	1
1. Model Names of Indoor/Outdoor Units.....	2
2. External Appearance.....	3
2.1 Indoor Units .....	3
2.2 Outdoor Units .....	4
3. Combination of Outdoor Units.....	5
4. Model Selection.....	6
Part 2 Specifications .....	9
1. Specifications .....	10
1.1 Outdoor Units .....	10
1.2 Indoor Units .....	21
Part 3 Refrigerant Circuit .....	49
1. Refrigerant Circuit .....	50
1.1 RXYQ5M (※ Products after January, 2004).....	50
1.2 RXYQ8, 10, 12M (※ Products after January, 2004).....	52
1.3 RXYQ14, 16M (※ Products after January, 2004) .....	54
1.4 Outdoor air processing unit FXMQ125~250MFV1 .....	56
2. Functional Parts Layout .....	57
2.1 RXYQ5M .....	57
2.2 RXYQ8, 10, 12M .....	58
2.3 RXYQ14, 16M .....	59
3. Refrigerant Flow for Each Operation Mode.....	60
Part 4 Function.....	73
1. Function general .....	74
1.1 Symbol .....	74
1.2 Operation Mode.....	75
2. Basic Control .....	76
2.1 Normal Operation .....	76
2.2 Compressor PI Control.....	77
2.3 Electronic Expansion Valve PI Control.....	83
2.4 Cooling Operation Fan Control.....	84

3. Special Control.....	85
3.1 Startup Control .....	85
3.2 Oil Return Operation .....	86
3.3 Defrosting Operation .....	88
3.4 Pump-down Residual Operation .....	89
3.5 Restart Standby.....	90
3.6 Stopping Operation .....	91
3.7 Pressure Equalization prior to Startup.....	93
4. Protection Control .....	94
4.1 High Pressure Protection Control.....	94
4.2 Low Pressure Protection Control.....	95
4.3 Discharge Pipe Protection Control .....	96
4.4 Inverter Protection Control .....	97
4.5 STD Compressor Overload Protection.....	98
5. Other Control.....	99
5.1 Outdoor Unit Rotation.....	99
5.2 Emergency Operation .....	100
5.3 Demand Operation .....	102
5.4 Heating operation prohibition .....	102
6. Outline of Control (Indoor Unit) .....	103
6.1 Drain Pump Control.....	103
6.2 Louver Control for Preventing Ceiling Dirt.....	105
6.3 Thermostat Sensor in Remote Controller.....	106
6.4 Freeze Prevention.....	108
6.5 Control of outdoor air Processing unit (Unique Control for Outdoor Air Processing Unit).....	109
 Part 5 Test Operation .....	 113
1. Test Operation .....	114
1.1 Procedure and Outline .....	114
1.2 Operation When Power is Turned On .....	117
2. Outdoor Unit PC Board Layout .....	118
3. Field Setting .....	119
3.1 Field Setting from Remote Controller .....	119
3.2 Field Setting from Outdoor Unit.....	132
 Part 6 Troubleshooting .....	 157
1. Troubleshooting by Remote Controller .....	160
1.1 The INSPECTION / TEST Button.....	160
1.2 Self-diagnosis by Wired Remote Controller .....	161
1.3 Self-diagnosis by Wireless Remote Controller .....	162
1.4 Operation of The Remote Controller's Inspection / Test Operation Button .....	165
1.5 Remote Controller Service Mode .....	166
1.6 Remote Controller Self-Diagnosis Function .....	168
2. Troubleshooting by Indication on the Remote Controller .....	173
2.1 "R0" Indoor Unit: Error of External Protection Device .....	173
2.2 "R1" Indoor Unit: PC Board Defect.....	174
2.3 "R3" Indoor Unit: Malfunction of Drain Level Control System (S1L) .....	175
2.4 "R5" Indoor Unit: Fan Motor (M1F) Lock, Overload.....	177

2.5	"R1" Indoor Unit: Malfunction of Swing Flap Motor (MA) .....	178
2.6	"R9" Indoor Unit: Malfunction of Moving Part of Electronic Expansion Valve (20E) .....	180
2.7	"RF" Indoor Unit: Drain Level above Limit.....	182
2.8	"RJ" Indoor Unit: Malfunction of Capacity Determination Device .....	183
2.9	"CY" Indoor Unit: Malfunction of Thermistor (R2T) for Heat Exchanger .....	184
2.10	"CS" Indoor Unit: Malfunction of Thermistor (R3T) for Gas Pipes.....	185
2.11	"CG" Indoor Unit: Malfunction of Thermistor (R1T) for Suction Air.....	186
2.12	"CU" Indoor Unit: Malfunction of Thermostat Sensor in Remote Controller .....	187
2.13	"E1" Outdoor Unit: PC Board Defect .....	188
2.14	"E3" Outdoor Unit: Actuation of High Pressure Switch .....	189
2.15	"E4" Outdoor Unit: Actuation of Low Pressure Sensor .....	190
2.16	"E5" Compressor Motor Lock .....	191
2.17	"E6" Compressor Motor Overcurrent/Lock .....	192
2.18	"E7" Malfunction of Outdoor Unit Fan Motor.....	193
2.19	"E9" Outdoor Unit: Malfunction of Moving Part of Electronic Expansion Valve (Y1E, Y2E).....	195
2.20	"F3" Outdoor Unit: Abnormal Discharge Pipe Temperature .....	197
2.21	"F6" Refrigerant Overcharged .....	198
2.22	"H1" Abnormal Outdoor Fan Motor Signal.....	199
2.23	"H9" Outdoor Unit: Malfunction of Thermistor for Outdoor Air (R1T).....	200
2.24	"J2" Current Sensor Malfunction.....	201
2.25	"J3" Outdoor Unit: Malfunction of Discharge Pipe Thermistor (R3, R31~33T) .....	202
2.26	"J5" Outdoor Unit: Malfunction of Thermistor (R2T) for Suction Pipe .....	203
2.27	"J6" Outdoor Unit: Malfunction of Thermistor (R4T) for Outdoor Unit Heat Exchanger .....	204
2.28	"J8" Malfunction of Oil Equalizing Pipe Thermistor (R7T).....	205
2.29	"J9" Malfunction of Receiver Gas Pipe Thermistor (R5T).....	206
2.30	"JR" Outdoor Unit: Malfunction of Discharge Pipe Pressure Sensor.....	207
2.31	"JC" Outdoor Unit: Malfunction of Suction Pipe Pressure Sensor .....	208
2.32	"L4" Outdoor Unit: Malfunction of Inverter Radiating Fin Temperature Rise.....	209
2.33	"L5" Outdoor Unit: Inverter Compressor Abnormal .....	210
2.34	"L8" Outdoor Unit: Inverter Current Abnormal.....	211
2.35	"L9" Outdoor Unit: Inverter Start up Error.....	212
2.36	"LC" Outdoor Unit: Malfunction of Transmission Between Inverter and Control PC Board .....	213
2.37	"P1" Outdoor Unit: Inverter Over-Ripple Protection .....	215
2.38	"P4" Outdoor Unit: Malfunction of Inverter Radiating Fin Temperature Rise Sensor .....	216
2.39	"UD" Low Pressure Drop Due to Refrigerant Shortage or Electronic Expansion Valve Failure.....	217
2.40	"U1" Reverse Phase, Open Phase.....	218
2.41	"U2" Power Supply Insufficient or Instantaneous Failure .....	219
2.42	"U3" Check Operation not executed .....	221
2.43	"U4" Malfunction of Transmission Between Indoor Units .....	222
2.44	"U5" Malfunction of Transmission Between Remote Controller and Indoor Unit.....	224
2.45	"U7" Malfunction of Transmission Between Outdoor Units.....	225
2.46	"U8" Malfunction of Transmission Between Master and Slave Remote Controllers .....	227

2.47	“U9” Malfunction of Transmission Between Indoor and Outdoor Units in the Same System .....	228
2.48	“UR” Excessive Number of Indoor Units .....	230
2.49	“UL” Address Duplication of Central Remote Controller .....	231
2.50	“UE” Malfunction of Transmission Between Central Remote Controller and Indoor Unit .....	232
2.51	“UF” Refrigerant System not Set, Incompatible Wiring/Piping .....	234
2.52	“UH” Malfunction of System, Refrigerant System Address Undefined .....	235
3.	Troubleshooting (OP: Central Remote Controller) .....	236
3.1	“UE” Malfunction of Transmission Between Central Remote Controller and Indoor Unit .....	236
3.2	“M1” PC Board Defect .....	237
3.3	“M8” Malfunction of Transmission Between Optional Controllers for Centralized Control .....	238
3.4	“M9” Improper Combination of Optional Controllers for Centralized Control .....	239
3.5	“ML” Address Duplication, Improper Setting .....	241
4.	Troubleshooting (OP: Schedule Timer) .....	242
4.1	“UE” Malfunction of Transmission Between Central Remote Controller and Indoor Unit .....	242
4.2	“M1” PC Board Defect .....	244
4.3	“M8” Malfunction of Transmission Between Optional Controllers for Centralized Control .....	245
4.4	“M9” Improper Combination of Optional Controllers for Centralized Control .....	246
4.5	“ML” Address Duplication, Improper Setting .....	248
5.	Troubleshooting (OP: Unified ON/OFF Controller) .....	249
5.1	Operation Lamp Blinks .....	249
5.2	Display “Under Host Computer Integrate Control” Blinks (Repeats Single Blink) .....	251
5.3	Display “Under Host Computer Integrate Control” Blinks (Repeats Double Blink) .....	254

## Part 7 Replacement procedure for INV compressor,

VRV II (RXYQ5M to 48M) .....	257
------------------------------	-----

1. Replacement procedure for INV compressor, VRV II (RXYQ5M-48M) .....	258
1.1 Replacement procedure .....	258

## Part 8 Appendix .....





1. Piping Diagrams .....	260
1.1 Outdoor Unit .....	260
1.2 Indoor Unit .....	263
2. Wiring Diagrams for Reference .....	269
2.1 Outdoor Unit .....	269
2.2 Field Wiring .....	272
2.3 Indoor Unit .....	275
3. List of Electrical and Functional Parts .....	293
3.1 Outdoor Unit .....	293
3.2 Indoor Side .....	295

4. Option List .....	301
4.1 Option List of Controllers .....	301
4.2 Option Lists (Outdoor Unit) .....	303
5. Piping Installation Point .....	304
5.1 Piping Installation Point .....	304
5.2 The Example of A Wrong Pattern .....	305
6. Selection of Pipe Size, Joints and Header .....	306
6.1 RXYQ5MY1B, RXYQ8MY1B, RXYQ10MY1B, RXYQ12MY1B, RXYQ14MY1B, RXYQ16MY1B .....	306
6.2 RXYQ18MY1B, RXYQ20MY1B, RXYQ22MY1B, RXYQ24MY1B, RXYQ26MY1B, RXYQ28MY1B, RXYQ30MY1B, RXYQ32MY1B, RXYQ34MY1B, RXYQ36MY1B, RXYQ38MY1B, RXYQ40MY1B, RXYQ42MY1B, RXYQ44MY1B, RXYQ46MY1B, RXYQ48MY1B .....	308
7. Thermistor Resistance / Temperature Characteristics .....	311
8. Pressure Sensor .....	313
9. Method of Replacing The Inverter's Power Transistors and Diode Modules .....	314
 Part 9 Precautions for New Refrigerant (R410) .....	 317
1. Precautions for New Refrigerant (R410) .....	318
1.1 Outline .....	318
1.2 Refrigerant Cylinders .....	320
1.3 Service Tools .....	321
 Index .....	 i
 Drawings & Flow Charts .....	 v







# 1. Introduction









## 1.1 Safety Cautions

### Cautions and Warnings

- Be sure to read the following safety cautions before conducting repair work.
- The caution items are classified into “ **Warning**” and “ **Caution**”. The “ **Warning**” items are especially important since they can lead to death or serious injury if they are not followed closely. The “ **Caution**” items can also lead to serious accidents under some conditions if they are not followed. Therefore, be sure to observe all the safety caution items described below.
- About the pictograms
  - △ This symbol indicates an item for which caution must be exercised.  
The pictogram shows the item to which attention must be paid.
  - This symbol indicates a prohibited action.  
The prohibited item or action is shown inside or near the symbol.
  - This symbol indicates an action that must be taken, or an instruction.  
The instruction is shown inside or near the symbol.
- After the repair work is complete, be sure to conduct a test operation to ensure that the equipment operates normally, and explain the cautions for operating the product to the customer

### 1.1.1 Caution in Repair

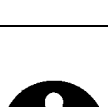

 <b>Warning</b>	
Be sure to disconnect the power cable plug from the plug socket before disassembling the equipment for a repair. Working on the equipment that is connected to a power supply can cause an electrical shock. If it is necessary to supply power to the equipment to conduct the repair or inspecting the circuits, do not touch any electrically charged sections of the equipment.	
If the refrigerant gas discharges during the repair work, do not touch the discharging refrigerant gas. The refrigerant gas can cause frostbite.	
When disconnecting the suction or discharge pipe of the compressor at the welded section, release the refrigerant gas completely at a well-ventilated place first. If there is a gas remaining inside the compressor, the refrigerant gas or refrigerating machine oil discharges when the pipe is disconnected, and it can cause injury.	
If the refrigerant gas leaks during the repair work, ventilate the area. The refrigerant gas can generate toxic gases when it contacts flames.	
The step-up capacitor supplies high-voltage electricity to the electrical components of the outdoor unit. Be sure to discharge the capacitor completely before conducting repair work. A charged capacitor can cause an electrical shock.	
Do not start or stop the air conditioner operation by plugging or unplugging the power cable plug. Plugging or unplugging the power cable plug to operate the equipment can cause an electrical shock or fire.	



 <b>Caution</b>	
Do not repair the electrical components with wet hands. Working on the equipment with wet hands can cause an electrical shock.	
Do not clean the air conditioner by splashing water. Washing the unit with water can cause an electrical shock.	
Be sure to provide the grounding when repairing the equipment in a humid or wet place, to avoid electrical shocks.	
Be sure to turn off the power switch and unplug the power cable when cleaning the equipment. The internal fan rotates at a high speed, and cause injury.	
Do not tilt the unit when removing it. The water inside the unit can spill and wet the furniture and floor.	
Be sure to check that the refrigerating cycle section has cooled down sufficiently before conducting repair work. Working on the unit when the refrigerating cycle section is hot can cause burns.	
Use the welder in a well-ventilated place. Using the welder in an enclosed room can cause oxygen deficiency.	

### 1.1.2 Cautions Regarding Products after Repair





 <b>Warning</b>	
Be sure to use parts listed in the service parts list of the applicable model and appropriate tools to conduct repair work. Never attempt to modify the equipment. The use of inappropriate parts or tools can cause an electrical shock, excessive heat generation or fire.	
When relocating the equipment, make sure that the new installation site has sufficient strength to withstand the weight of the equipment. If the installation site does not have sufficient strength and if the installation work is not conducted securely, the equipment can fall and cause injury.	
Be sure to install the product correctly by using the provided standard installation frame. Incorrect use of the installation frame and improper installation can cause the equipment to fall, resulting in injury.	For integral units only
Be sure to install the product securely in the installation frame mounted on a window frame. If the unit is not securely mounted, it can fall and cause injury.	For integral units only
Be sure to use an exclusive power circuit for the equipment, and follow the technical standards related to the electrical equipment, the internal wiring regulations and the instruction manual for installation when conducting electrical work. Insufficient power circuit capacity and improper electrical work can cause an electrical shock or fire.	





 <b>Warning</b>	
Be sure to use the specified cable to connect between the indoor and outdoor units. Make the connections securely and route the cable properly so that there is no force pulling the cable at the connection terminals. Improper connections can cause excessive heat generation or fire.	
When connecting the cable between the indoor and outdoor units, make sure that the terminal cover does not lift off or dismount because of the cable. If the cover is not mounted properly, the terminal connection section can cause an electrical shock, excessive heat generation or fire.	
Do not damage or modify the power cable. Damaged or modified power cable can cause an electrical shock or fire. Placing heavy items on the power cable, and heating or pulling the power cable can damage the cable.	
Do not mix air or gas other than the specified refrigerant (R410A) in the refrigerant system. If air enters the refrigerating system, an excessively high pressure results, causing equipment damage and injury.	
If the refrigerant gas leaks, be sure to locate the leak and repair it before charging the refrigerant. After charging refrigerant, make sure that there is no refrigerant leak. If the leak cannot be located and the repair work must be stopped, be sure to perform pump-down and close the service valve, to prevent the refrigerant gas from leaking into the room. The refrigerant gas itself is harmless, but it can generate toxic gases when it contacts flames, such as fan and other heaters, stoves and ranges.	
When replacing the coin battery in the remote controller, be sure to disposed of the old battery to prevent children from swallowing it. If a child swallows the coin battery, see a doctor immediately.	

 <b>Caution</b>	
Installation of a leakage breaker is necessary in some cases depending on the conditions of the installation site, to prevent electrical shocks.	
Do not install the equipment in a place where there is a possibility of combustible gas leaks. If a combustible gas leaks and remains around the unit, it can cause a fire.	
Be sure to install the packing and seal on the installation frame properly. If the packing and seal are not installed properly, water can enter the room and wet the furniture and floor.	For integral units only

### 1.1.3 Inspection after Repair





 <b>Warning</b>	
Check to make sure that the power cable plug is not dirty or loose, then insert the plug into a power outlet all the way. If the plug has dust or loose connection, it can cause an electrical shock or fire.	
If the power cable and lead wires have scratches or deteriorated, be sure to replace them. Damaged cable and wires can cause an electrical shock, excessive heat generation or fire.	
Do not use a joined power cable or extension cable, or share the same power outlet with other electrical appliances, since it can cause an electrical shock, excessive heat generation or fire.	

 <b>Caution</b>	
Check to see if the parts and wires are mounted and connected properly, and if the connections at the soldered or crimped terminals are secure. Improper installation and connections can cause excessive heat generation, fire or an electrical shock.	
If the installation platform or frame has corroded, replace it. Corroded installation platform or frame can cause the unit to fall, resulting in injury.	
Check the grounding, and repair it if the equipment is not properly grounded. Improper grounding can cause an electrical shock.	
Be sure to measure the insulation resistance after the repair, and make sure that the resistance is 1 Mohm or higher. Faulty insulation can cause an electrical shock.	
Be sure to check the drainage of the indoor unit after the repair. Faulty drainage can cause the water to enter the room and wet the furniture and floor.	

## 1.1.4 Using Icons

Icons are used to attract the attention of the reader to specific information. The meaning of each icon is described in the table below:

## 1.1.5 Using Icons List

Icon	Type of Information	Description
 Note:	Note	A “note” provides information that is not indispensable, but may nevertheless be valuable to the reader, such as tips and tricks.
 Caution	Caution	A “caution” is used when there is danger that the reader, through incorrect manipulation, may damage equipment, lose data, get an unexpected result or has to restart (part of) a procedure.
 Warning	Warning	A “warning” is used when there is danger of personal injury.
	Reference	A “reference” guides the reader to other places in this binder or in this manual, where he/she will find additional information on a specific topic.

## 1.2 PREFACE

Thank you for your continued patronage of Daikin products.

This is the new service manual for Daikin's Year 2004 VRVII series Heat Pump System. Daikin offers a wide range of models to respond to building and office air conditioning needs. We are confident that customers will be able to find the models that best suit their needs.

This service manual contains information regarding the servicing of VRVII series Heat Pump System.

There are some changes in piping and control system for products before December 2003. Please refer the service information for product before December, 2003 to the service manual Si39-302.

October, 2004

After Sales Service Division

# Part 1

## General Information

1. Model Names of Indoor/Outdoor Units.....	2
2. External Appearance.....	3
2.1 Indoor Units .....	3
2.2 Outdoor Units .....	4
3. Combination of Outdoor Units.....	5
4. Model Selection.....	6

# 1. Model Names of Indoor/Outdoor Units

## Indoor Units

Type		Model Name											Power Supply
Ceiling Mounted Cassette Type (Double Flow)	FXCQ	20M	25M	32M	40M	50M	63M	80M	—	125M	—	—	VE
Ceiling Mounted Cassette Type (Multi Flow) 600x600	FXZQ	20M	25M	32M	40M	50M	—	—	—	—	—	—	
Ceiling Mounted Cassette Type (Multi Flow)	FXFQ	—	25M	32M	40M	50M	63M	80M	100M	125M	—	—	
Ceiling Mounted Cassette Corner Type	FXKQ	—	25M	32M	40M	—	63M	—	—	—	—	—	
Slim Ceiling Mounted Duct Type	FXDQ	20N	25N	32N	40N	50N	63N	—	—	—	—	—	
Ceiling Mounted Built-In Type	FXSQ	20M	25M	32M	40M	50M	63M	80M	100M	125M	—	—	
Ceiling Mounted Duct Type	FXMQ	—	—	—	40M	50M	63M	80M	100M	125M	200M	250M	
Ceiling Suspended Type	FXHQ	—	—	32M	—	—	63M	—	100M	—	—	—	
Wall Mounted Type	FXAQ	20M	25M	32M	40M	50M	63M	—	—	—	—	—	
Floor Standing Type	FXLQ	20M	25M	32M	40M	50M	63M	—	—	—	—	—	
Concealed Floor Standing Type	FXNQ	20M	25M	32M	40M	50M	63M	—	—	—	—	—	
Outdoor Air Processing Unit	FXMQ-MF	—	—	—	—	—	—	—	—	125MF	200MF	250MF	V1

## Indoor Units (Connection Unit Series)

Type		Model Name											Power Supply
Ceiling Suspended Cassette Type	FXUQ	—	—	—	—	—	—	71M	100M	125M	—	—	V1
Wall Mounted Type	FXAQ-MH	20MH	25MH	32MH	40MH	50MH	—	—	—	—	—	—	
Floor Standing Type	FXLQ-MH	20MH	25MH	32MH	40MH	50MH	—	—	—	—	—	—	
Connection Unit	BEVQ-M	50M	50M	50M	50M	50M	—	71M	100M	125M	—	—	VE

Note: BEV unit is required for each indoor unit.













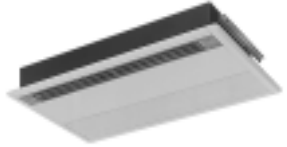

## Outdoor Units

Series		Model Name											Power Supply
Heat Pump	RXYQ	5M	8M	10M	12M	14M	16M	18M	20M	22M	24M	26M	Y1B
Series		Model Name											Power Supply
Heat Pump	RXYQ	28M	30M	32M	34M	36M	38M	40M	42M	44M	46M	48M	Y1B

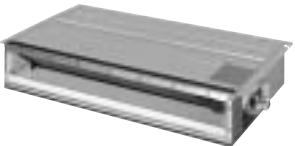
VE: 1φ, 220~240V, 50Hz, 1φ, 220V, 60Hz  
 V1: 1φ, 220~240V, 50Hz  
 Y1B: 3φ, 380~415V, 50Hz

## 2. External Appearance

### 2.1 Indoor Units

<p>Ceiling Mounted Cassette Type (Double Flow)</p> <p>FXCQ20M FXCQ25M FXCQ32M FXCQ40M FXCQ50M FXCQ63M FXCQ80M FXCQ125M</p> 	<p>Wall Mounted Type</p> <p>FXAQ20M FXAQ25M FXAQ32M FXAQ40M FXAQ50M FXAQ63M</p> 
<p>Ceiling Mounted Cassette Type (Multi Flow) 600x600</p> <p>FXZQ20M FXZQ25M FXZQ32M FXZQ40M FXZQ50M</p> 	<p>Floor Standing Type</p> <p>FXLQ20M(H) FXLQ25M(H) FXLQ32M(H) FXLQ40M(H) FXLQ50M(H) FXLQ63M(H)</p> 
<p>Ceiling Mounted Cassette Type (Multi Flow)</p> <p>FXFQ25M FXFQ32M FXFQ40M FXFQ50M FXFQ63M FXFQ80M FXFQ100M FXFQ125M</p> 	<p>Concealed Floor Standing Type</p> <p>FXNQ20M FXNQ25M FXNQ32M FXNQ40M FXNQ50M FXNQ63M</p> 
<p>Ceiling Mounted Cassette Corner Type</p> <p>FXKQ25M FXKQ32M FXKQ40M FXKQ63M</p> 	<p>New Ceiling Suspended Cassette Type</p> <p>FXUQ71M + BEVQ71M FXUQ100M + BEVQ100M FXUQ125M + BEVQ125M</p> <p>Connection Unit</p> 
<p>Slim Ceiling Mounted Duct Type</p> <p>FXDQ20N FXDQ25N FXDQ32N FXDQ40N FXDQ50N FXDQ63N</p> 	<p>Wall Mounted Type (Connection Unit Series)</p> <p>FXAQ20MH FXAQ25MH FXAQ32MH FXAQ40MH FXAQ50MH</p> <p>+BEVQ50M</p> 
<p>Ceiling Mounted Built-In Type</p> <p>FXSQ20M FXSQ25M FXSQ32M FXSQ40M FXSQ50M FXSQ63M FXSQ80M FXSQ100M FXSQ125M</p> 	<p>Floor Standing Type (Connection Unit Series)</p> <p>FXLQ20MH FXLQ25MH FXLQ32MH FXLQ40MH FXLQ50MH</p> <p>+BEVQ50M</p> 
<p>Ceiling Mounted Duct Type</p> <p>FXMQ40M FXMQ50M FXMQ63M FXMQ80M FXMQ100M FXMQ125M FXMQ200M FXMQ250M</p> <p>FXMQ40~125M</p> <p>FXMQ200 · 250M</p> 	<p>Outdoor Air Processing Unit</p> 
<p>Ceiling Suspended Type</p> <p>FXHQ32M FXHQ63M FXHQ100M</p> 	

## 2.2 Outdoor Units

**RXYQ5M**



5HP

**RXYQ8M, 10M**



8,10HP

**RXYQ12M, 14M, 16M**



12,14,16HP

**RXYQ18M, 20M**



18, 20HP

**RXYQ22M, 24M, 26M**



22, 24, 26HP

**RXYQ28M, 30M, 32M**



28, 30, 32HP

**RXYQ34M, 36M**



34, 36HP

**RXYQ38M, 40M, 42M**



38, 40, 42HP

**RXYQ44M, 46M, 48M**



44, 46, 48HP

### 3. Combination of Outdoor Units

System Capacity	Number of units	Module						Outdoor Unit Multi Connection Piping Kit+Pipe Size Reducer (Option)
		5	8	10	12	14	16	
5HP	1							—
8HP	1							
10HP	1							
12HP	1							
14HP	1							
16HP	1							
18HP	2							Heat Pump: BHFP22M90+BHFP22M90P
20HP	2							
22HP	2							
24HP	2							
26HP	2							
28HP	2							
30HP	2							
32HP	2							
34HP	3							Heat Pump: BHFP22M135+BHFP22M135P
36HP	3							
38HP	3							
40HP	3							
42HP	3							
44HP	3							
46HP	3							
48HP	3							



**Note:** For multiple connection of 18HP systems or more, an optional Daikin outdoor unit multi connection piping kit is required.



## 4. Model Selection

### VRV II Heat Pump Series

#### Connectable indoor units number and capacity

HP	5HP	8HP	10HP	12HP	14HP	16HP
System name	RXYQ5M	RXYQ8M	RXYQ10M	RXYQ12M	RXYQ14M	RXYQ16M
Outdoor unit 1	RXYQ5M	RXYQ8M	RXYQ10M	RXYQ12M	RXYQ14M	RXYQ16M
Outdoor unit 2	–	–	–	–	–	–
Outdoor unit 3	–	–	–	–	–	–
Total number of connectable indoor units	8	13	16	19	20	20
Total capacity of connectable indoor units (kW)	7.0~18.2	11.2~29.1	14.0~36.4	16.8~43.6	20.0~52.0	22.5~58.5

HP	18HP	20HP	22HP	24HP	26HP	28HP
System name	RXYQ18M	RXYQ20M	RXYQ22M	RXYQ24M	RXYQ26M	RXYQ28M
Outdoor unit 1	RXYQ8M	RXYQ10M	RXYQ10M	RXYQ10M	RXYQ10M	RXYQ12M
Outdoor unit 2	RXYQ10M	RXYQ10M	RXYQ12M	RXYQ14M	RXYQ16M	RXYQ16M
Outdoor unit 3	–	–	–	–	–	–
Total number of connectable indoor units	20	20	22	32	32	32
Total capacity of connectable indoor units (kW)	25.2~65.5	28.0~72.8	30.8~80.0	34.0~88.4	36.5~94.9	39.3~102.1

HP	30HP	32HP	34HP	36HP	38HP	40HP
System name	RXYQ30M	RXYQ32M	RXYQ34M	RXYQ36M	RXYQ38M	RXYQ40M
Outdoor unit 1	RXYQ14M	RXYQ16M	RXYQ10M	RXYQ10M	RXYQ10M	RXYQ10M
Outdoor unit 2	RXYQ16M	RXYQ16M	RXYQ10M	RXYQ10M	RXYQ12M	RXYQ14M
Outdoor unit 3	–	–	RXYQ14M	RXYQ16M	RXYQ16M	RXYQ16M
Total number of connectable indoor units	32	32	34	36	38	40
Total capacity of connectable indoor units (kW)	42.5~110.5	45.0~117.0	48.0~124.8	50.5~131.3	53.3~138.5	56.5~146.9

HP	42HP	44HP	46HP	48HP
System name	RXYQ42M	RXYQ44M	RXYQ46M	RXYQ48M
Outdoor unit 1	RXYQ10M	RXYQ12M	RXYQ14M	RXYQ16M
Outdoor unit 2	RXYQ16M	RXYQ16M	RXYQ16M	RXYQ16M
Outdoor unit 3	RXYQ16M	RXYQ16M	RXYQ16M	RXYQ16M
Total number of connectable indoor units	40	40	40	40
Total capacity of connectable indoor units (kW)	59.0~153.4	61.8~160.6	65.0~169.0	67.5~175.5

## Connectable Indoor Unit

Type		Model Name											Power Supply
Ceiling Mounted Cassette Type (Double Flow)	FXCQ	20M	25M	32M	40M	50M	63M	80M	—	125M	—	—	VE
Ceiling Mounted Cassette Type (Multi Flow) 600x600	FXZQ	20M	25M	32M	40M	50M	—	—	—	—	—	—	
Ceiling Mounted Cassette Type (Multi Flow)	FXFQ	—	25M	32M	40M	50M	63M	80M	100M	125M	—	—	
Ceiling Mounted Cassette Corner Type	FXKQ	—	25M	32M	40M	—	63M	—	—	—	—	—	
Slim Ceiling Mounted Duct Type	FXDQ	20N	25N	32N	40N	50N	63N	—	—	—	—	—	
Ceiling Mounted Built-In Type	FXSQ	20M	25M	32M	40M	50M	63M	80M	100M	125M	—	—	
Ceiling Mounted Duct Type	FXMQ	—	—	—	40M	50M	63M	80M	100M	125M	200M	250M	
Ceiling Suspended Type	FXHQ	—	—	32M	—	—	63M	—	100M	—	—	—	
Wall Mounted Type	FXAQ	20M	25M	32M	40M	50M	63M	—	—	—	—	—	
Floor Standing Type	FXLQ	20M	25M	32M	40M	50M	63M	—	—	—	—	—	
Concealed Floor Standing Type	FXNQ	20M	25M	32M	40M	50M	63M	—	—	—	—	—	
Outdoor Air Processing Unit	FXMQ-MF	—	—	—	—	—	—	—	—	125MF	200MF	250MF	V1

## Connectable Indoor Unit (Connection Unit Series)

Type		Model Name											Power Supply
Ceiling Suspended Cassette Type	FXUQ	—	—	—	—	—	—	71M	100M	125M	—	—	V1
Wall Mounted Type	FXAQ-MH	20MH	25MH	32MH	40MH	50MH	—	—	—	—	—	—	
Floor Standing Type	FXLQ-MH	20MH	25MH	32MH	40MH	50MH	—	—	—	—	—	—	
Connection Unit	BEVQ-M	50M	50M	50M	50M	50M	—	71M	100M	125M	—	—	VE

Note: BEV unit is required for each indoor unit.

## Indoor unit capacity

New refrigerant model code	P20 type	P25 type	P32 type	P40 type	P50 type	P63 type	P80 type	P100 type	P125 type	P200 type	P250 type
Selecting model capacity	2.2 kW	2.8 kW	3.5 kW	4.5 kW	5.6 kW	7.0 kW	9.0 kW	11.2 kW	14.0 kW	22.4 kW	28.0 kW
Equivalent output	0.8HP	1HP	1.25HP	1.6HP	2.0HP	2.5HP	3.2HP	4HP	5HP	8HP	10HP

Use the above tables to determine the capacities of indoor units to be connected. Make sure the total capacity of indoor units connected to each outdoor unit is within the specified value (kW).

- The total capacity of connected indoor units must be within a range of 50 to 130% of the rated capacity of the outdoor unit.
- In some models, it is not possible to connect the maximum number of connectable indoor units. Select models so the total capacity of connected indoor units conforms to the specification.



# Part 2

# Specifications

1. Specifications .....	10
1.1 Outdoor Units .....	10
1.2 Indoor Units .....	21

# 1. Specifications

## 1.1 Outdoor Units

Model Name			RXYQ5MY1B	RXYQ8MY1B
H1 Cooling Capacity (19.5°CWB)	kcal / h		12,500	20,000
	Btu / h		49,500	78,900
	kW		14.5	23.1
H2 Cooling Capacity (19.0°CWB)	kW		14.0	22.4
H3 Heating Capacity	kcal / h		13,800	21,500
	Btu / h		54,600	85,400
	kW		16.0	25.0
Casing Color			Ivory White (5Y7.5/1)	Ivory White (5Y7.5/1)
Dimensions: (HxWxD)			mm 1600x635x765	1600x930x765
Heat Exchanger			Cross Fin Coil	Cross Fin Coil
Comp.	Type		Hermetically Sealed Scroll Type	Hermetically Sealed Scroll Type
	Piston Displacement	m <sup>3</sup> /h	13.72	13.72+10.47
	Number of Revolutions	r.p.m	6480	6480, 2900
	Motor OutputxNumber of Units	kW	3.2x1	(1.2+4.5)x1
Starting Method			Soft start	Soft start
Fan	Type		Propeller Fan	Propeller Fan
	Motor Output	kW	0.35x1	0.75x1
	Air Flow Rate	m <sup>3</sup> /min	75	175
	Drive		Direct Drive	Direct Drive
Connecting Pipes	Liquid Pipe	mm	φ9.5 (Flare Connection)	φ9.5 (Flare Connection)
	Gas Pipe	mm	φ15.9 (Flare Connection)	φ19.1 (Brazing Connection)
	Oil Equalizing Pipe	mm	—	—
Machine Weight (Mass)			kg 160	230
Safety Devices			High Pressure Switch, Fan Driver Overload Protector, Inverter Overload Protector, Fusible Plugs	High Pressure Switch, Fan Driver Overload Protector, Over Current Relay, Inverter Overload Protector, Fusible Plugs
Defrost Method			Deicer	Deicer
Capacity Control			% 24~100	14~100
Refrigerant	Refrigerant Name		R410A	R410A
	Charge	kg	5.6	8.6
	Control		Electronic Expansion Valve	Electronic Expansion Valve
Refrigerator Oil			Synthetic (ether) oil	Synthetic (ether) oil
	Charge Volume	L	1.2	1.9+1.6
Standard Accessories			Installation Manual, Operation Manual, Connection Pipes, Clamps	Installation Manual, Operation Manual, Connection Pipes, Clamps
Drawing No.			4D038964B	4D038965B

### Notes:

- H1 Indoor temp. : 27°CDB, 19.5°CWB / outdoor temp. : 35°CDB / Equivalent piping length : 7.5m, level difference : 0m.
- H2 Indoor temp. : 27°CDB, 19.0°CWB / outdoor temp. : 35°CDB / Equivalent piping length : 7.5m, level difference : 0m.
- H3 Indoor temp. : 20°CDB / outdoor temp. : 7°CDB, 6°CWB / Equivalent piping length : 7.5m, level difference : 0m.

Conversion Formulae
kcal/h=kWx860
Btu/h=kWx3414
cfm=m <sup>3</sup> /minx35.3

Model Name			RXYQ10MY1B	RXYQ12MY1B
H1 Cooling Capacity (19.5°CWB)	kcal / h		25,000	30,000
	Btu / h		98,700	118,000
	kW		28.9	34.6
H2 Cooling Capacity (19.0°CWB)	kW		28.0	33.5
H3 Heating Capacity	kcal / h		27,000	32,300
	Btu / h		108,000	128,000
	kW		31.5	37.5
Casing Color			Ivory White (5Y7.5/1)	Ivory White (5Y7.5/1)
Dimensions: (HxWxD)			1600x930x765	1600x1240x765
Heat Exchanger			Cross Fin Coil	Cross Fin Coil
Comp.	Type		Hermetically Sealed Scroll Type	Hermetically Sealed Scroll Type
	Piston Displacement	m <sup>3</sup> /h	13.72+10.47	13.72+10.47
	Number of Revolutions	r.p.m	6480, 2900	6480, 2900
	Motor OutputxNumber of Units	kW	(2.7+4.5)x1	(4.2+4.5)x1
	Starting Method		Soft start	Soft start
Fan	Type		Propeller Fan	Propeller Fan
	Motor Output	kW	0.75x1	0.75x1
	Air Flow Rate	m <sup>3</sup> /min	180	210
	Drive		Direct Drive	Direct Drive
Connecting Pipes	Liquid Pipe	mm	φ9.5 (Flare Connection)	φ12.7 (Flare Connection)
	Gas Pipe	mm	φ22.2 (Brazing Connection)	φ28.6 (Brazing Connection)
	Oil Equalizing Pipe	mm	—	—
Machine Weight (Mass)			230	281
Safety Devices			High Pressure Switch, Fan Driver Overload Protector, Over Current Relay, Inverter Overload Protector, Fusible Plugs	High Pressure Switch, Fan Driver Overload Protector, Over Current Relay, Inverter Overload Protector, Fusible Plugs
Defrost Method			Deicer	Deicer
Capacity Control			%	14~100
Refrigerant	Refrigerant Name		R410A	R410A
	Charge	kg	9.6	11.4
	Control		Electronic Expansion Valve	Electronic Expansion Valve
Refrigerator Oil			Synthetic (ether) oil	Synthetic (ether) oil
	Charge Volume	L	1.9+1.6	1.9+1.6
Standard Accessories			Installation Manual, Operation Manual, Connection Pipes, Clamps	Installation Manual, Operation Manual, Connection Pipes, Clamps
Drawing No.			4D038966B	4D038967C

**Notes:**

- H1 Indoor temp. : 27°CDB, 19.5°CWB / outdoor temp. : 35°CDB / Equivalent piping length : 7.5m, level difference : 0m.
- H2 Indoor temp. : 27°CDB, 19.0°CWB / outdoor temp. : 35°CDB / Equivalent piping length : 7.5m, level difference : 0m.
- H3 Indoor temp. : 20°CDB / outdoor temp. : 7°CDB, 6°CWB / Equivalent piping length : 7.5m, level difference : 0m.

**Conversion Formulae**

kcal/h=kW×860  
Btu/h=kW×3414  
cfm=m<sup>3</sup>/min×35.3

Model Name			RXYQ14MY1B	RXYQ16MY1B
H1 Cooling Capacity (19.5°CWB)	kcal / h		35,500	40,000
	Btu / h		141,000	157,000
	kW		41.3	45.9
H2 Cooling Capacity (19.0°CWB)	kW		40.0	44.5
H3 Heating Capacity	kcal / h		38,700	43,000
	Btu / h		154,000	171,000
	kW		45.0	50.0
Casing Color			Ivory White (5Y7.5/1)	Ivory White (5Y7.5/1)
Dimensions: (HxWxD)			mm 1600x1240x765	1600x1240x765
Heat Exchanger			Cross Fin Coil	Cross Fin Coil
Comp.	Type		Hermetically Sealed Scroll Type	Hermetically Sealed Scroll Type
	Piston Displacement	m³/h	13.72+10.47+10.47	13.72+10.47+10.47
	Number of Revolutions	r.p.m	6480, 2900x2	6480, 2900x2
	Motor OutputxNumber of Units	kW	(2.0+4.5+4.5)x1	(3.0+4.5+4.5)x1
	Starting Method		Soft start	Soft start
Fan	Type		Propeller Fan	Propeller Fan
	Motor Output	kW	0.75x1	0.75x1
	Air Flow Rate	m³/min	210	210
	Drive		Direct Drive	Direct Drive
Connecting Pipes	Liquid Pipe	mm	φ12.7 (Flare Connection)	φ12.7 (Flare Connection)
	Gas Pipe	mm	φ28.6 (Brazing Connection)	φ28.6 (Brazing Connection)
	Oil Equalizing Pipe	mm	—	—
Machine Weight (Mass)			kg 323	325
Safety Devices			High Pressure Switch, Fan Driver Overload Protector, Over Current Relay, Inverter Overload Protector, Fusible Plugs	High Pressure Switch, Fan Driver Overload Protector, Over Current Relay, Inverter Overload Protector, Fusible Plugs
Defrost Method			Deicer	Deicer
Capacity Control			% 10~100	10~100
Refrigerant	Refrigerant Name		R410A	R410A
	Charge	kg	12.9	14.4
	Control		Electronic Expansion Valve	Electronic Expansion Valve
Refrigerator Oil			Synthetic (ether) oil	Synthetic (ether) oil
	Charge Volume	L	1.9+1.6+1.6	1.9+1.6+1.6
Standard Accessories			Installation Manual, Operation Manual, Connection Pipes, Clamps	Installation Manual, Operation Manual, Connection Pipes, Clamps
Drawing No.			4D038968C	4D038969C

**Notes:**

- H1 Indoor temp. : 27°CDB, 19.5°CWB / outdoor temp. : 35°CDB / Equivalent piping length : 7.5m, level difference : 0m.
- H2 Indoor temp. : 27°CDB, 19.0°CWB / outdoor temp. : 35°CDB / Equivalent piping length : 7.5m, level difference : 0m.
- H3 Indoor temp. : 20°CDB / outdoor temp. : 7°CDB, 6°CWB / Equivalent piping length : 7.5m, level difference : 0m.

Conversion Formulae
kcal/h=kWx860
Btu/h=kWx3414
cfm=m³/minx35.3

Model Name (Combination Unit)			RXYQ18MY1B	RXYQ20MY1B
Model Name (Independent Unit)			RXYQ8MY1B+RXYQ10MY1B	RXYQ10MY1B+RXYQ10MY1B
H1 Cooling Capacity (19.5°CWB)	kcal / h		45,000	50,000
	Btu / h		178,000	197,000
	kW		52.0	57.8
H2 Cooling Capacity (19.0°CWB)	kW		50.4	56.0
H3 Heating Capacity	kcal / h		48,500	54,000
	Btu / h		193,000	216,000
	kW		56.5	63.0
Casing Color			Ivory White (5Y7.5/1)	Ivory White (5Y7.5/1)
Dimensions: (HxWxD)		mm	(1600x930x765)+(1600x930x765)	(1600x930x765)+(1600x930x765)
Heat Exchanger			Cross Fin Coil	Cross Fin Coil
Comp.	Type		Hermetically Sealed Scroll Type	Hermetically Sealed Scroll Type
	Piston Displacement	m <sup>3</sup> /h	(13.72+10.47)×2	(13.72+10.47)×2
	Number of Revolutions	r.p.m	(6480, 2900)×2	(6480, 2900)×2
	Motor Output×Number of Units	kW	(1.2+4.5)+(2.7+4.5)	(2.7+4.5)×2
	Starting Method		Soft start	Soft start
Fan	Type		Propeller Fan	Propeller Fan
	Motor Output	kW	0.75×2	0.75×2
	Air Flow Rate	m <sup>3</sup> /min	175+180	180+180
	Drive		Direct Drive	Direct Drive
Connecting Pipes	Liquid Pipe	mm	φ15.9 (Brazing Connection)	φ15.9 (Brazing Connection)
	Gas Pipe	mm	φ28.6 (Brazing Connection)	φ28.6 (Brazing Connection)
	Oil Equalizing Pipe	mm	φ6.4 (Flare Connection)	φ6.4 (Flare Connection)
Machine Weight (Mass)		kg	230+230	230+230
Safety Devices			High Pressure Switch, Fan Driver Overload Protector, Over Current Relay, Inverter Overload Protector, Fusible Plugs	High Pressure Switch, Fan Driver Overload Protector, Over Current Relay, Inverter Overload Protector, Fusible Plugs
Defrost Method			Deicer	Deicer
Capacity Control		%	7~100	7~100
Refrigerant	Refrigerant Name		R410A	R410A
	Charge	kg	8.6+9.6	9.6+9.6
	Control		Electronic Expansion Valve	Electronic Expansion Valve
Refrigerator Oil			Synthetic (ether) oil	Synthetic (ether) oil
	Charge Volume	L	(1.9+1.6)+(1.9+1.6)	(1.9+1.6)+(1.9+1.6)
Standard Accessories			Installation Manual, Operation Manual, Connection Pipes, Clamps	Installation Manual, Operation Manual, Connection Pipes, Clamps
Drawing No.			4D038965B, 4D038966B	4D038966B

**Notes:**

- H1 Indoor temp. : 27°CDB, 19.5°CWB / outdoor temp. : 35°CDB / Equivalent piping length : 7.5m, level difference : 0m.
- H2 Indoor temp. : 27°CDB, 19.0°CWB / outdoor temp. : 35°CDB / Equivalent piping length : 7.5m, level difference : 0m.
- H3 Indoor temp. : 20°CDB / outdoor temp. : 7°CDB, 6°CWB / Equivalent piping length : 7.5m, level difference : 0m.

Conversion Formulae
kcal/h=kW×860
Btu/h=kW×3414
cfm=m <sup>3</sup> /min×35.3



Model Name (Combination Unit)		RXYQ22MY1B		RXYQ24MY1B		
Model Name (Independent Unit)		RXYQ10MY1B+RXYQ12MY1B		RXYQ10MY1B+RXYQ14MY1B		
H1 Cooling Capacity (19.5°CWB)	kcal / h	55,000		60,500		
	Btu / h	217,000		240,000		
	kW	63.5		70.2		
H2 Cooling Capacity (19.0°CWB)	kW	61.5		68.0		
H3 Heating Capacity	kcal / h	59,300		65,700		
	Btu / h	236,000		262,000		
	kW	69.0		76.5		
Casing Color		Ivory White (5Y7.5/1)		Ivory White (5Y7.5/1)		
Dimensions: (HxWxD)		mm	(1600x930x765)+(1600x1240x765)		(1600x930x765)+(1600x1240x765)	
Heat Exchanger		Cross Fin Coil		Cross Fin Coil		
Comp.	Type		Hermetically Sealed Scroll Type		Hermetically Sealed Scroll Type	
	Piston Displacement	m³/h	(13.72+10.47)×2		(13.72+10.47)+(13.72+10.47+10.47)	
	Number of Revolutions	r.p.m	(6480, 2900)×2		(6480, 2900)+(6480, 2900×2)	
	Motor Output×Number of Units	kW	(2.7+4.5)+(4.2+4.5)		(2.7+4.5)+(2.0+4.5+4.5)	
	Starting Method		Soft start		Soft start	
Fan	Type		Propeller Fan		Propeller Fan	
	Motor Output	kW	0.75×2		0.75×2	
	Air Flow Rate	m³/min	180+210		180+210	
	Drive		Direct Drive		Direct Drive	
Connecting Pipes	Liquid Pipe	mm	φ15.9 (Brazing Connection)		φ15.9 (Brazing Connection)	
	Gas Pipe	mm	φ28.6 (Brazing Connection)		φ34.9 (Brazing Connection)	
	Oil Equalizing Pipe	mm	φ6.4 (Flare Connection)		φ6.4 (Flare Connection)	
Machine Weight (Mass)		kg	230+281		230+323	
Safety Devices		High Pressure Switch, Fan Driver Overload Protector, Over Current Relay, Inverter Overload Protector, Fusible Plugs		High Pressure Switch, Fan Driver Overload Protector, Over Current Relay, Inverter Overload Protector, Fusible Plugs		
Defrost Method		Deicer		Deicer		
Capacity Control		%	7~100		6~100	
Refrigerant	Refrigerant Name		R410A		R410A	
	Charge	kg	9.6+11.4		9.6+12.9	
	Control		Electronic Expansion Valve		Electronic Expansion Valve	
Refrigerator Oil			Synthetic (ether) oil		Synthetic (ether) oil	
	Charge Volume	L	(1.9+1.6)+(1.9+1.6)		(1.9+1.6)+(1.9+1.6+1.6)	
Standard Accessories		Installation Manual, Operation Manual, Connection Pipes, Clamps		Installation Manual, Operation Manual, Connection Pipes, Clamps		
Drawing No.		4D038966B, 4D038967C		4D038966B, 4D038968C		

**Notes:**

- H1 Indoor temp. : 27°CDB, 19.5°CWB / outdoor temp. : 35°CDB / Equivalent piping length : 7.5m, level difference : 0m.
- H2 Indoor temp. : 27°CDB, 19.0°CWB / outdoor temp. : 35°CDB / Equivalent piping length : 7.5m, level difference : 0m.
- 3 Indoor temp. : 20°CDB / outdoor temp. : 7°CDB, 6°CWB / Equivalent piping length : 7.5m, level difference : 0m.

Conversion Formulae
kcal/h=kW×860
Btu/h=kW×3414
cfm=m³/min×35.3

Model Name (Combination Unit)		RXYQ26MY1B		RXYQ28MY1B		
Model Name (Independent Unit)		RXYQ10MY1B+RXYQ16MY1B		RXYQ12MY1B+RXYQ16MY1B		
H1 Cooling Capacity (19.5°CWB)	kcal / h	65,000		70,000		
	Btu / h	256,000		275,000		
	kW	74.9		80.5		
H2 Cooling Capacity (19.0°CWB)	kW	72.5		78.0		
H3 Heating Capacity	kcal / h	70,000		75,300		
	Btu / h	279,000		299,000		
	kW	81.5		87.5		
Casing Color		Ivory White (5Y7.5/1)		Ivory White (5Y7.5/1)		
Dimensions: (H×W×D)		mm	(1600×930×765)+(1600×1240×765)		(1600×1240×765)+(1600×1240×765)	
Heat Exchanger		Cross Fin Coil		Cross Fin Coil		
Comp.	Type		Hermetically Sealed Scroll Type		Hermetically Sealed Scroll Type	
	Piston Displacement	m³/h	(13.72+10.47)+(13.72+10.47+10.47)		(13.72+10.47)+(13.72+10.47+10.47)	
	Number of Revolutions	r.p.m	(6480, 2900)+(6480, 2900×2)		(6480, 2900)+(6480, 2900×2)	
	Motor Output×Number of Units	kW	(2.7+4.5)+(3.0+4.5+4.5)		(4.2+4.5)+(3.0+4.5+4.5)	
	Starting Method		Soft start		Soft start	
Fan	Type		Propeller Fan		Propeller Fan	
	Motor Output	kW	0.75×2		0.75×2	
	Air Flow Rate	m³/min	180+210		210+210	
	Drive		Direct Drive		Direct Drive	
Connecting Pipes	Liquid Pipe	mm	φ19.1 (Brazing Connection)		φ19.1 (Brazing Connection)	
	Gas Pipe	mm	φ34.9 (Brazing Connection)		φ34.9 (Brazing Connection)	
	Oil Equalizing Pipe	mm	φ6.4 (Flare Connection)		φ6.4 (Flare Connection)	
Machine Weight (Mass)		kg	230+325		281+325	
Safety Devices		High Pressure Switch, Fan Driver Overload Protector, Over Current Relay, Inverter Overload Protector, Fusible Plugs		High Pressure Switch, Fan Driver Overload Protector, Over Current Relay, Inverter Overload Protector, Fusible Plugs		
Defrost Method		Deicer		Deicer		
Capacity Control		%	6~100		6~100	
Refrigerant	Refrigerant Name		R410A		R410A	
	Charge	kg	9.6+14.4		11.4+14.4	
	Control		Electronic Expansion Valve		Electronic Expansion Valve	
Refrigerator Oil	Synthetic (ether) oil		Synthetic (ether) oil		Synthetic (ether) oil	
	Charge Volume	L	(1.9+1.6)+(1.9+1.6+1.6)		(1.9+1.6)+(1.9+1.6+1.6)	
Standard Accessories		Installation Manual, Operation Manual, Connection Pipes, Clamps		Installation Manual, Operation Manual, Connection Pipes, Clamps		
Drawing No.		4D038966B, 4D038969C		4D038967C, 4D038969C		

**Notes:**

- H1 Indoor temp. : 27°CDB, 19.5°CWB / outdoor temp. : 35°CDB / Equivalent piping length : 7.5m, level difference : 0m.
- H2 Indoor temp. : 27°CDB, 19.0°CWB / outdoor temp. : 35°CDB / Equivalent piping length : 7.5m, level difference : 0m.
- H3 Indoor temp. : 20°CDB / outdoor temp. : 7°CDB, 6°CWB / Equivalent piping length : 7.5m, level difference : 0m.

Conversion Formulae
kcal/h=kW×860
Btu/h=kW×3414
cfm=m³/min×35.3

Model Name (Combination Unit)			RXYQ30MY1B	RXYQ32MY1B
Model Name (Independent Unit)			RXYQ14MY1B+RXYQ16MY1B	RXYQ16MY1B+RXYQ16MY1B
H1 Cooling Capacity (19.5°CWB)	kcal / h		75,500	80,000
	Btu / h		298,000	314,000
	kW		87.2	91.9
H2 Cooling Capacity (19.0°CWB)	kW		84.5	89.0
H3 Heating Capacity	kcal / h		81,700	86,000
	Btu / h		325,000	342,000
	kW		95.0	100
Casing Color			Ivory White (5Y7.5/1)	Ivory White (5Y7.5/1)
Dimensions: (HxWxD)			mm (1600x1240x765)+(1600x1240x765)	(1600x1240x765)+(1600x1240x765)
Heat Exchanger			Cross Fin Coil	Cross Fin Coil
Comp.	Type		Hermetically Sealed Scroll Type	Hermetically Sealed Scroll Type
	Piston Displacement	m³/h	(13.72+10.47+10.47)×2	(13.72+10.47+10.47)×2
	Number of Revolutions	r.p.m	(6480, 2900×2)×2	(6480, 2900×2)×2
	Motor Output×Number of Units	kW	(2.0+4.5+4.5)+(3.0+4.5+4.5)	(3.0+4.5+4.5)+(3.0+4.5+4.5)
	Starting Method		Soft start	Soft start
Fan	Type		Propeller Fan	Propeller Fan
	Motor Output	kW	0.75×2	0.75×2
	Air Flow Rate	m³/min	210×2	210×2
	Drive		Direct Drive	Direct Drive
Connecting Pipes	Liquid Pipe	mm	φ19.1 (Brazing Connection)	φ19.1 (Brazing Connection)
	Gas Pipe	mm	φ34.9 (Brazing Connection)	φ34.9 (Brazing Connection)
	Oil Equalizing Pipe	mm	φ6.4 (Flare Connection)	φ6.4 (Flare Connection)
Machine Weight (Mass)		kg	323+325	325+325
Safety Devices			High Pressure Switch, Fan Driver Overload Protector, Over Current Relay, Inverter Overload Protector, Fusible Plugs	High Pressure Switch, Fan Driver Overload Protector, Over Current Relay, Inverter Overload Protector, Fusible Plugs
Defrost Method			Deicer	Deicer
Capacity Control		%	5-100	5-100
Refrigerant	Refrigerant Name		R410A	R410A
	Charge	kg	12.9+14.4	14.4+14.4
	Control		Electronic Expansion Valve	Electronic Expansion Valve
Refrigerator Oil			Synthetic (ether) oil	Synthetic (ether) oil
	Charge Volume	L	(1.9+1.6+1.6)+(1.9+1.6+1.6)	(1.9+1.6+1.6)+(1.9+1.6+1.6)
Standard Accessories			Installation Manual, Operation Manual, Connection Pipes, Clamps	Installation Manual, Operation Manual, Connection Pipes, Clamps
Drawing No.			4D038968C, 4D038969C	4D038969C

**Notes:**

- H1 Indoor temp. : 27°CDB, 19.5°CWB / outdoor temp. : 35°CDB / Equivalent piping length : 7.5m, level difference : 0m.
- H2 Indoor temp. : 27°CDB, 19.0°CWB / outdoor temp. : 35°CDB / Equivalent piping length : 7.5m, level difference : 0m.
- H3 Indoor temp. : 20°CDB / outdoor temp. : 7°CDB, 6°CWB / Equivalent piping length : 7.5m, level difference : 0m.

Conversion Formulae
kcal/h=kW×860
Btu/h=kW×3414
cfm=m³/min×35.3

Model Name (Combination Unit)		RXYQ34MY1B		RXYQ36MY1B		
Model Name (Independent Unit)		RXYQ10MY1B+RXYQ10MY1B+RXYQ14MY1B		RXYQ10MY1B+RXYQ10MY1B+RXYQ16MY1B		
H1 Cooling Capacity (19.5°CWB)	kcal / h	85,500		90,000		
	Btu / h	338,000		354,000		
	kW	99.1		104		
H2 Cooling Capacity (19.0°CWB)	kW	96.0		101		
H3 Heating Capacity	kcal / h	92,700		97,000		
	Btu / h	370,000		387,000		
	kW	108		113		
Casing Color		Ivory White (5Y7.5/1)		Ivory White (5Y7.5/1)		
Dimensions: (H×W×D)		mm	(1600×930×765)+(1600×930×765)+(1600×1240×765)		(1600×930×765)+(1600×930×765)+(1600×1240×765)	
Heat Exchanger		Cross Fin Coil		Cross Fin Coil		
Comp.	Type		Hermetically Sealed Scroll Type		Hermetically Sealed Scroll Type	
	Piston Displacement	m³/h	(13.72+10.47)×2+(13.72+10.47+10.47)		(13.72+10.47)×2+(13.72+10.47+10.47)	
	Number of Revolutions	r.p.m	(6480, 2900)×2+(6480, 2900×2)		(6480, 2900)×2+(6480, 2900×2)	
	Motor Output×Number of Units	kW	(2.7+4.5)+(2.7+4.5)+(2.0+4.5+4.5)		(2.7+4.5)+(2.7+4.5)+(3.0+4.5+4.5)	
	Starting Method		Soft start		Soft start	
Fan	Type		Propeller Fan		Propeller Fan	
	Motor Output	kW	0.75×3		0.75×3	
	Air Flow Rate	m³/min	180+180+210		180+180+210	
	Drive		Direct Drive		Direct Drive	
Connecting Pipes	Liquid Pipe	mm	φ19.1 (Brazing Connection)		φ19.1 (Brazing Connection)	
	Gas Pipe	mm	φ34.9 (Brazing Connection)		φ41.3 (Brazing Connection)	
	Oil Equalizing Pipe	mm	φ6.4 (Flare Connection)		φ6.4 (Flare Connection)	
Machine Weight (Mass)		kg	230+230+323		230+230+325	
Safety Devices		High Pressure Switch, Fan Driver Overload Protector, Over Current Relay, Inverter Overload Protector, Fusible Plugs		High Pressure Switch, Fan Driver Overload Protector, Over Current Relay, Inverter Overload Protector, Fusible Plugs		
Defrost Method		Deicer		Deicer		
Capacity Control		%	4~100		4~100	
Refrigerant	Refrigerant Name		R410A		R410A	
	Charge	kg	9.6+9.6+12.9		9.6+9.6+14.4	
	Control		Electronic Expansion Valve		Electronic Expansion Valve	
Refrigerator Oil			Synthetic (ether) oil		Synthetic (ether) oil	
	Charge Volume	L	(1.9+1.6)+(1.9+1.6)+(1.9+1.6+1.6)		(1.9+1.6)+(1.9+1.6)+(1.9+1.6+1.6)	
Standard Accessories		Installation Manual, Operation Manual, Connection Pipes, Clamps		Installation Manual, Operation Manual, Connection Pipes, Clamps		
Drawing No.		4D038966B, 4D038968C		4D038966B, 4D038969C		

**Notes:**

- H1 Indoor temp. : 27°CDB, 19.5°CWB / outdoor temp. : 35°CDB / Equivalent piping length : 7.5m, level difference : 0m.
- H2 Indoor temp. : 27°CDB, 19.0°CWB / outdoor temp. : 35°CDB / Equivalent piping length : 7.5m, level difference : 0m.
- H3 Indoor temp. : 20°CDB / outdoor temp. : 7°CDB, 6°CWB / Equivalent piping length : 7.5m, level difference : 0m.

**Conversion Formulae**

kcal/h=kW×860  
Btu/h=kW×3414  
cfm=m³/min×35.3

Model Name (Combination Unit)		RXYQ38MY1B		RXYQ40MY1B		
Model Name (Independent Unit)		RXYQ10MY1B+RXYQ12MY1B+RXYQ16MY1B		RXYQ10MY1B+RXYQ14MY1B+RXYQ16MY1B		
H1 Cooling Capacity (19.5°CWB)	kcal / h	95,000		101,000		
	Btu / h	374,000		397,000		
	kW	109		117		
H2 Cooling Capacity (19.0°CWB)	kW	106		113		
H3 Heating Capacity	kcal / h	102,000		109,000		
	Btu / h	407,000		433,000		
	kW	119		127		
Casing Color		Ivory White (5Y7.5/1)		Ivory White (5Y7.5/1)		
Dimensions: (H×W×D)		mm	(1600×930×765)+(1600×1240×765)+(1600×1240×765)	(1600×930×765)+(1600×1240×765)+(1600×1240×765)		
Heat Exchanger		Cross Fin Coil		Cross Fin Coil		
Comp.	Type		Hermetically Sealed Scroll Type		Hermetically Sealed Scroll Type	
	Piston Displacement	m³/h	(13.72+10.47)×2+(13.72+10.47+10.47)		(13.72+10.47)+(13.72+10.47+10.47)×2	
	Number of Revolutions	r.p.m	(6480, 2900)×2+(6480, 2900×2)		(6480, 2900), (6480, 2900×2)×2	
	Motor Output×Number of Units	kW	(2.7+4.5)+(4.2+4.5)+(3.0+4.5+4.5)		(2.7+4.5)+(2.0+4.5+4.5)+(3.0+4.5+4.5)	
	Starting Method		Soft start		Soft start	
Fan	Type		Propeller Fan		Propeller Fan	
	Motor Output	kW	0.75×3		0.75×3	
	Air Flow Rate	m³/min	180+210+210		180+210+210	
	Drive		Direct Drive		Direct Drive	
Connecting Pipes	Liquid Pipe	mm	φ19.1 (Brazing Connection)		φ19.1 (Brazing Connection)	
	Gas Pipe	mm	φ41.3 (Brazing Connection)		φ41.3 (Brazing Connection)	
	Oil Equalizing Pipe	mm	φ6.4 (Flare Connection)		φ6.4 (Flare Connection)	
Machine Weight (Mass)		kg	230+281+325		230+323+325	
Safety Devices		High Pressure Switch, Fan Driver Overload Protector, Over Current Relay, Inverter Overload Protector, Fusible Plugs		High Pressure Switch, Fan Driver Overload Protector, Over Current Relay, Inverter Overload Protector, Fusible Plugs		
Defrost Method		Deicer		Deicer		
Capacity Control		%	4~100		4~100	
Refrigerant	Refrigerant Name		R410A		R410A	
	Charge	kg	9.6+11.4+14.4		9.6+12.9+14.4	
	Control		Electronic Expansion Valve		Electronic Expansion Valve	
Refrigerator Oil			Synthetic (ether) oil		Synthetic (ether) oil	
	Charge Volume	L	(1.9+1.6)+(1.9+1.6)+(1.9+1.6+1.6)		(1.9+1.6)+(1.9+1.6+1.6)+(1.9+1.6+1.6)	
Standard Accessories		Installation Manual, Operation Manual, Connection Pipes, Clamps		Installation Manual, Operation Manual, Connection Pipes, Clamps		
Drawing No.		4D038966B, 4D038967C, 4D038969C		4D038966B, 4D038968C, 4D038969C		

**Notes:**

- H1 Indoor temp. : 27°CDB, 19.5°CWB / outdoor temp. : 35°CDB / Equivalent piping length : 7.5m, level difference : 0m.
- H2 Indoor temp. : 27°CDB, 19.0°CWB / outdoor temp. : 35°CDB / Equivalent piping length : 7.5m, level difference : 0m.
- H3 Indoor temp. : 20°CDB / outdoor temp. : 7°CDB, 6°CWB / Equivalent piping length : 7.5m, level difference : 0m.

Conversion Formulae
kcal/h=kW×860
Btu/h=kW×3414
cfm=m³/min×35.3

Model Name (Combination Unit)		RXYQ42MY1B		RXYQ44MY1B		
Model Name (Independent Unit)		RXYQ10MY1B+RXYQ16MY1B+RXYQ16MY1B		RXYQ12MY1B+RXYQ16MY1B+RXYQ16MY1B		
H1 Cooling Capacity (19.5°CWB)	kcal / h	105,000		110,000		
	Btu / h	413,000		432,000		
	kW	121		127		
H2 Cooling Capacity (19.0°CWB)	kW	117		123		
H3 Heating Capacity	kcal / h	113,000		118,000		
	Btu / h	450,000		470,000		
	kW	132		138		
Casing Color		Ivory White (5Y7.5/1)		Ivory White (5Y7.5/1)		
Dimensions: (H×W×D)		mm	(1600×930×765)+(1600×1240×765)+(1600×1240×765)	(1600×1240×765)+(1600×1240×765)+(1600×1240×765)		
Heat Exchanger		Cross Fin Coil		Cross Fin Coil		
Comp.	Type		Hermetically Sealed Scroll Type		Hermetically Sealed Scroll Type	
	Piston Displacement	m³/h	(13.72+10.47)+(13.72+10.47+10.47)×2		(13.72+10.47)+(13.72+10.47+10.47)×2	
	Number of Revolutions	r.p.m	(6480, 2900), (6480, 2900×2)×2		(6480, 2900), (6480, 2900×2)×2	
	Motor Output×Number of Units	kW	(2.7+4.5)+(3.0+4.5+4.5)×2		(4.2+4.5)+(3.0+4.5+4.5)×2	
	Starting Method		Soft start		Soft start	
Fan	Type		Propeller Fan		Propeller Fan	
	Motor Output	kW	0.75×3		0.75×3	
	Air Flow Rate	m³/min	180+210+210		210+210+210	
	Drive		Direct Drive		Direct Drive	
Connecting Pipes	Liquid Pipe	mm	φ19.1 (Brazing Connection)		φ19.1 (Brazing Connection)	
	Gas Pipe	mm	φ41.3 (Brazing Connection)		φ41.3 (Brazing Connection)	
	Oil Equalizing Pipe	mm	φ6.4 (Flare Connection)		φ6.4 (Flare Connection)	
Machine Weight (Mass)		kg	230+325+325		281+325+325	
Safety Devices		High Pressure Switch, Fan Driver Overload Protector, Over Current Relay, Inverter Overload Protector, Fusible Plugs		High Pressure Switch, Fan Driver Overload Protector, Over Current Relay, Inverter Overload Protector, Fusible Plugs		
Defrost Method		Deicer		Deicer		
Capacity Control		%	4~100		4~100	
Refrigerant	Refrigerant Name		R410A		R410A	
	Charge	kg	9.6+14.4+14.4		11.4+14.4+14.4	
	Control		Electronic Expansion Valve		Electronic Expansion Valve	
Refrigerator Oil			Synthetic (ether) oil		Synthetic (ether) oil	
	Charge Volume	L	(1.9+1.6)+(1.9+1.6+1.6)+(1.9+1.6+1.6)		(1.9+1.6)+(1.9+1.6+1.6)+(1.9+1.6+1.6)	
Standard Accessories		Installation Manual, Operation Manual, Connection Pipes, Clamps		Installation Manual, Operation Manual, Connection Pipes, Clamps		
Drawing No.		4D038966B, 4D038969C		4D038967C, 4D038969C		

**Notes:**

- H1 Indoor temp. : 27°CDB, 19.5°CWB / outdoor temp. : 35°CDB / Equivalent piping length : 7.5m, level difference : 0m.
- H2 Indoor temp. : 27°CDB, 19.0°CWB / outdoor temp. : 35°CDB / Equivalent piping length : 7.5m, level difference : 0m.
- H3 Indoor temp. : 20°CDB / outdoor temp. : 7°CDB, 6°CWB / Equivalent piping length : 7.5m, level difference : 0m.

**Conversion Formulae**

kcal/h=kW×860  
Btu/h=kW×3414  
cfm=m³/min×35.3

Model Name (Combination Unit)		RXYQ46MY1B		RXYQ48MY1B		
Model Name (Independent Unit)		RXYQ14MY1B+RXYQ16MY1B+RXYQ16MY1B		RXYQ16MY1B+RXYQ16MY1B+RXYQ16MY1B		
H1 Cooling Capacity (19.5°CWB)	kcal / h	116,000		120,000		
	Btu / h	455,000		471,000		
	kW	133		138		
H2 Cooling Capacity (19.0°CWB)	kW	129		134		
H3 Heating Capacity	kcal / h	125,000		129,000		
	Btu / h	496,000		513,000		
	kW	145		150		
Casing Color		Ivory White (5Y7.5/1)		Ivory White (5Y7.5/1)		
Dimensions: (H×W×D)		mm	(1600×1240×765)+(1600×1240×765)+(1600×1240×765)	(1600×1240×765)+(1600×1240×765)+(1600×1240×765)		
Heat Exchanger		Cross Fin Coil		Cross Fin Coil		
Comp.	Type		Hermetically Sealed Scroll Type		Hermetically Sealed Scroll Type	
	Piston Displacement	m³/h	(13.72+10.47+10.47)×3		(13.72+10.47+10.47)×3	
	Number of Revolutions	r.p.m	(6480, 2900×2)×3		(6480, 2900×2)×3	
	Motor Output×Number of Units	kW	(2.0+4.5+4.5)+(3.0+4.5+4.5)×2		(3.0+4.5+4.5)×3	
	Starting Method		Soft start		Soft start	
Fan	Type		Propeller Fan		Propeller Fan	
	Motor Output	kW	0.75×3		0.75×3	
	Air Flow Rate	m³/min	210+210+210		210+210+210	
	Drive		Direct Drive		Direct Drive	
Connecting Pipes	Liquid Pipe	mm	φ19.1 (Brazing Connection)		φ19.1 (Brazing Connection)	
	Gas Pipe	mm	φ41.3 (Brazing Connection)		φ41.3 (Brazing Connection)	
	Oil Equalizing Pipe	mm	φ6.4 (Flare Connection)		φ6.4 (Flare Connection)	
Machine Weight (Mass)		kg	323+325+325		325+325+325	
Safety Devices		High Pressure Switch, Fan Driver Overload Protector, Over Current Relay, Inverter Overload Protector, Fusible Plugs		High Pressure Switch, Fan Driver Overload Protector, Over Current Relay, Inverter Overload Protector, Fusible Plugs		
Defrost Method		Deicer		Deicer		
Capacity Control		%	3~100		3~100	
Refrigerant	Refrigerant Name		R410A		R410A	
	Charge	kg	12.9+14.4+14.4		14.4+14.4+14.4	
	Control		Electronic Expansion Valve		Electronic Expansion Valve	
Refrigerator Oil			Synthetic (ether) oil		Synthetic (ether) oil	
	Charge Volume	L	(1.9+1.6+1.6)+(1.9+1.6+1.6)+(1.9+1.6+1.6)		(1.9+1.6+1.6)+(1.9+1.6+1.6)+(1.9+1.6+1.6)	
Standard Accessories		Installation Manual, Operation Manual, Connection Pipes, Clamps		Installation Manual, Operation Manual, Connection Pipes, Clamps		
Drawing No.		4D038968C, 4D038969C		4D038969C		

**Notes:**

- H1 Indoor temp. : 27°CDB, 19.5°CWB / outdoor temp. : 35°CDB / Equivalent piping length : 7.5m, level difference : 0m.  
H2 Indoor temp. : 27°CDB, 19.0°CWB / outdoor temp. : 35°CDB / Equivalent piping length : 7.5m, level difference : 0m.  
H3 Indoor temp. : 20°CDB / outdoor temp. : 7°CDB, 6°CWB / Equivalent piping length : 7.5m, level difference : 0m.

Conversion Formulae
kcal/h=kW×860
Btu/h=kW×3414
cfm=m³/min×35.3

## 1.2 Indoor Units

### Ceiling Mounted Cassette Type (Double Flow)

Model		FXCQ20MVE	FXCQ25MVE	FXCQ32MVE	FXCQ40MVE		
H1 Cooling Capacity (19.5°CWB)	kcal/h	2,000	2,500	3,150	4,000		
	Btu/h	7,900	9,900	12,500	15,900		
	kW	2.3	2.9	3.7	4.7		
H2 Cooling Capacity (19.0°CWB)		kW	2.2	2.8	3.6	4.5	
H3 Heating Capacity	kcal/h	2,200	2,800	3,400	4,300		
	Btu/h	8,500	10,900	13,600	17,000		
	kW	2.5	3.2	4.0	5.0		
Casing		Galvanized Steel Plate	Galvanized Steel Plate	Galvanized Steel Plate	Galvanized Steel Plate		
Dimensions: (HxWxD)		mm	305x775x600	305x775x600	305x775x600	305x990x600	
Coil (Cross Fin Coil)	RowsxStagesxFin Pitch	mm	2x10x1.5	2x10x1.5	2x10x1.5	2x10x1.5	
	Face Area	m <sup>2</sup>	2x0.100	2x0.100	2x0.100	2x0.145	
Fan	Model		D17K2AA1	D17K2AB1	D17K2AB1	2D17K1AA1	
	Type		Sirocco Fan	Sirocco Fan	Sirocco Fan	Sirocco Fan	
	Motor Output x Number of Units	W	10x1	15x1	15x1	20x1	
	Air Flow Rate (H/L)	m <sup>3</sup> /min	7/5	9/6.5	9/6.5	12/9	
		cfm	247/177	318/230	318/230	424/318	
Drive		Direct Drive	Direct Drive	Direct Drive	Direct Drive		
Temperature Control		Microprocessor Thermostat for Cooling and Heating	Microprocessor Thermostat for Cooling and Heating	Microprocessor Thermostat for Cooling and Heating	Microprocessor Thermostat for Cooling and Heating		
Sound Absorbing Thermal Insulation Material		Glass Wool/Urethane Foam	Glass Wool/Urethane Foam	Glass Wool/Urethane Foam	Glass Wool/Urethane Foam		
Piping Connections	Liquid Pipes	mm	φ6.4 (Flare Connection)	φ6.4 (Flare Connection)	φ6.4 (Flare Connection)	φ6.4 (Flare Connection)	
	Gas Pipes	mm	φ12.7 (Flare Connection)	φ12.7 (Flare Connection)	φ12.7 (Flare Connection)	φ12.7 (Flare Connection)	
	Drain Pipe	mm	VP25 ( External Dia. 32 ) ( Internal Dia. 25 )	VP25 ( External Dia. 32 ) ( Internal Dia. 25 )	VP25 ( External Dia. 32 ) ( Internal Dia. 25 )	VP25 ( External Dia. 32 ) ( Internal Dia. 25 )	
Machine Weight (Mass)		kg	26	26	26	31	
H5 Sound Level (H/L) (220V)		dBA	32/27	34/28	34/28	34/29	
Safety Devices		Fuse, Thermal Protector for Fan Motor	Fuse, Thermal Protector for Fan Motor	Fuse, Thermal Protector for Fan Motor	Fuse, Thermal Protector for Fan Motor		
Refrigerant Control		Electronic Expansion Valve	Electronic Expansion Valve	Electronic Expansion Valve	Electronic Expansion Valve		
Connectable outdoor unit		R410A M Series	R410A M Series	R410A M Series	R410A M Series		
Decoration Panels (Option)	Model		BYBC32G-W1	BYBC32G-W1	BYBC32G-W1	BYBC50G-W1	
	Panel Color		White (10Y9/0.5)	White (10Y9/0.5)	White (10Y9/0.5)	White (10Y9/0.5)	
	Dimensions: (HxWxD)		mm	53x1,030x680	53x1,030x680	53x1,030x680	53x1,245x680
	Air Filter		Resin Net (with Mold Resistant)	Resin Net (with Mold Resistant)	Resin Net (with Mold Resistant)	Resin Net (with Mold Resistant)	
Weight		kg	8	8	8	8.5	
Standard Accessories		Operation Manual, Installation Manual, Paper Pattern for Installation, Washer for Hanging Brackets, Clamp Metal, Drain Hose, Insulation for Fitting, Washer Fixing Plates, Sealing Pads, Clamps, Screws, Washers.	Operation Manual, Installation Manual, Paper Pattern for Installation, Washer for Hanging Brackets, Clamp Metal, Drain Hose, Insulation for Fitting, Washer Fixing Plates, Sealing Pads, Clamps, Screws, Washers.	Operation Manual, Installation Manual, Paper Pattern for Installation, Washer for Hanging Brackets, Clamp Metal, Drain Hose, Insulation for Fitting, Washer Fixing Plates, Sealing Pads, Clamps, Screws, Washers.	Operation Manual, Installation Manual, Paper Pattern for Installation, Washer for Hanging Brackets, Clamp Metal, Drain Hose, Insulation for Fitting, Washer Fixing Plates, Sealing Pads, Clamps, Screws, Washers.		
Drawing No.		3D039413					

#### Notes:

- H1 Indoor temp. : 27°CDB, 19.5°CWB / outdoor temp.: 35°CDB / Equivalent piping length: 7.5m, level difference: 0m.
- H2 Indoor temp. : 27°CDB, 19.0°CWB / outdoor temp.: 35°CDB / Equivalent piping length: 7.5m, level difference: 0m.
- H3 Indoor temp. : 20°CDB / outdoor temp.: 7°CDB, 6°CWB / Equivalent piping length: 7.5m, level difference: 0m. (Heat pump only)
- 4 Capacities are net, including a deduction for cooling (an addition for heating) for indoor fan motor heat.
- H5 Anechoic chamber conversion value, measured under JISB8616 conditions. During actual operation, these values are normally somewhat higher as a result of ambient conditions.

#### Conversion Formulae

$$\begin{aligned} \text{kcal/h} &= \text{kW} \times 860 \\ \text{Btu/h} &= \text{kW} \times 3414 \\ \text{cfm} &= \text{m}^3/\text{min} \times 35.3 \end{aligned}$$



**Ceiling Mounted Cassette Type (Double Flow)**

Model		FXCQ50MVE	FXCQ63MVE	FXCQ80MVE	FXCQ125MVE	
H1 Cooling Capacity (19.5°CWB)	kcal/h	5,000	6,300	8,000	12,500	
	Btu/h	19,900	25,000	31,800	49,600	
	kW	5.8	7.3	9.3	14.5	
H2 Cooling Capacity (19.0°CWB)	kW	5.6	7.1	9.0	14.0	
H3 Heating Capacity	kcal/h	5,400	6,900	8,600	13,800	
	Btu/h	21,500	27,300	34,100	54,600	
	kW	6.3	8.0	10.0	16.0	
Casing		Galvanized Steel Plate	Galvanized Steel Plate	Galvanized Steel Plate	Galvanized Steel Plate	
Dimensions: (HxWxD)		mm	305x990x600	305x1,175x600	305x1,665x600	
Coil (Cross Fin Coil)	RowsxStagesxFin Pitch	mm	2x10x1.5	2x10x1.5	2x10x1.5	
	Face Area	m <sup>2</sup>	2x0.145	2x0.184	2x0.287	
Fan	Model		2D17K1AA1	2D17K2AA1VE	3D17K2AA1	3D17K2AB1
	Type		Sirocco Fan	Sirocco Fan	Sirocco Fan	Sirocco Fan
	Motor Output x Number of Units	W	20x1	30x1	50x1	85x1
	Air Flow Rate (H/L)	m <sup>3</sup> /min	12/9	16.5/13	26/21	33/25
		cfm	424/318	582/459	918/741	1,165/883
Drive		Direct Drive	Direct Drive	Direct Drive	Direct Drive	
Temperature Control		Microprocessor Thermostat for Cooling and Heating	Microprocessor Thermostat for Cooling and Heating	Microprocessor Thermostat for Cooling and Heating	Microprocessor Thermostat for Cooling and Heating	
Sound Absorbing Thermal Insulation Material		Glass Wool/Urethane Foam	Glass Wool/Urethane Foam	Glass Wool/Urethane Foam	Glass Wool/Urethane Foam	
Piping Connections	Liquid Pipes	mm	φ6.4 (Flare Connection)	φ9.5 (Flare Connection)	φ9.5 (Flare Connection)	φ9.5 (Flare Connection)
	Gas Pipes	mm	φ12.7 (Flare Connection)	φ15.9 (Flare Connection)	φ15.9 (Flare Connection)	φ15.9 (Flare Connection)
	Drain Pipe	mm	VP25 ( External Dia. 32 Internal Dia. 25 )	VP25 ( External Dia. 32 Internal Dia. 25 )	VP25 ( External Dia. 32 Internal Dia. 25 )	VP25 ( External Dia. 32 Internal Dia. 25 )
Machine Weight (Mass)	kg	32	35	47	48	
H5 Sound Level (H/L)	dBA	34/29	37/32	39/34	44/38	
Safety Devices		Fuse, Thermal Protector for Fan Motor	Fuse, Thermal Protector for Fan Motor	Fuse, Thermal Protector for Fan Motor	Fuse, Thermal Protector for Fan Motor	
Refrigerant Control		Electronic Expansion Valve	Electronic Expansion Valve	Electronic Expansion Valve	Electronic Expansion Valve	
Connectable outdoor unit		R410A M Series	R410A M Series	R410A M Series	R410A M Series	
Decoration Panels (Option)	Model		BYBC50G-W1	BYBC63G-W1	BYBC125G-W1	BYBC125G-W1
	Panel Color		White (10Y9/0.5)	White (10Y9/0.5)	White (10Y9/0.5)	White (10Y9/0.5)
	Dimensions: (HxWxD)	mm	53x1,245x680	53x1,430x680	53x1,920x680	53x1,920x680
	Air Filter		Resin Net (with Mold Resistant)	Resin Net (with Mold Resistant)	Resin Net (with Mold Resistant)	Resin Net (with Mold Resistant)
	Weight	kg	8.5	9.5	12	12
Standard Accessories		Operation Manual, Installation Manual, Paper Pattern for Installation, Washer for Hanging Brackets, Clamp Metal, Drain Hose, Insulation for Fitting, Washer Fixing Plates, Sealing Pads, Clamps, Screws, Washers.	Operation Manual, Installation Manual, Paper Pattern for Installation, Washer for Hanging Brackets, Clamp Metal, Drain Hose, Insulation for Fitting, Washer Fixing Plates, Sealing Pads, Clamps, Screws, Washers.	Operation Manual, Installation Manual, Paper Pattern for Installation, Washer for Hanging Brackets, Clamp Metal, Drain Hose, Insulation for Fitting, Washer Fixing Plates, Sealing Pads, Clamps, Screws, Washers.	Operation Manual, Installation Manual, Paper Pattern for Installation, Washer for Hanging Brackets, Clamp Metal, Drain Hose, Insulation for Fitting, Washer Fixing Plates, Sealing Pads, Clamps, Screws, Washers.	
Drawing No.		3D039413				

**Notes:**

- H1 Indoor temp. : 27°CDB, 19.5°CWB / outdoor temp.: 35°CDB / Equivalent piping length: 7.5m, level difference: 0m.
- H2 Indoor temp. : 27°CDB, 19.0°CWB / outdoor temp.: 35°CDB / Equivalent piping length: 7.5m, level difference: 0m.
- H3 Indoor temp. : 20°CDB / outdoor temp.: 7°CDB, 6°CWB / Equivalent piping length; 7.5m, level difference: 0m. (Heat pump only)
- 4 Capacities are net, including a deduction for cooling (an addition for heating) for indoor fan motor heat.
- H5 Anechoic chamber conversion value, measured under JISB8616 conditions. During actual operation, these values are normally somewhat higher as a result of ambient conditions.

Conversion Formulae

kcal/h=kWx860  
Btu/h=kWx3414  
cfm=m<sup>3</sup>/minx35.3

## Ceiling Mounted Cassette Type (Multi Flow) 600×600

Model			FXZQ20MVE	FXZQ25MVE	FXZQ32MVE	
H1 Cooling Capacity (19.5°CWB)		kcal/h	2,000	2,500	3,150	
		Btu/h	7,900	9,900	12,500	
		kW	2.3	2.9	3.7	
H2 Cooling Capacity (19.0°CWB)		kW	2.2	2.8	3.6	
H3 Heating Capacity		kcal/h	2,200	2,800	3,400	
		Btu/h	8,500	10,900	13,600	
		kW	2.5	3.2	4.0	
Casing			Galvanized Steel Plate	Galvanized Steel Plate	Galvanized Steel Plate	
Dimensions: (H×W×D)		mm	260×575×575	260×575×575	260×575×575	
Coil (Cross Fin Coil)	Rows×Stages×Fin Pitch	mm	2×10×1.5	2×10×1.5	2×10×1.5	
	Face Area	m <sup>2</sup>	0.269	0.269	0.269	
Fan	Model		QTS32C15M	QTS32C15M	QTS32C15M	
	Type		Turbo Fan	Turbo Fan	Turbo Fan	
	Motor Output × Number of Units	W	55×1	55×1	55×1	
	Air Flow Rate (H/L)	m <sup>3</sup> /min	9/7	9/7	9.5/7.5	
		cfm	318/247	318/247	335/265	
Drive			Direct Drive	Direct Drive	Direct Drive	
Temperature Control			Microprocessor Thermostat for Cooling and Heating	Microprocessor Thermostat for Cooling and Heating	Microprocessor Thermostat for Cooling and Heating	
Sound Absorbing Thermal Insulation Material			Foamed Polystyrene/ Foamed Polyethylene	Foamed Polystyrene/ Foamed Polyethylene	Foamed Polystyrene/ Foamed Polyethylene	
Piping Connections	Liquid Pipes	mm	φ6.4 (Flare Connection)	φ6.4 (Flare Connection)	φ6.4 (Flare Connection)	
	Gas Pipes	mm	φ12.7 (Flare Connection)	φ12.7 (Flare Connection)	φ12.7 (Flare Connection)	
	Drain Pipe	mm	VP20 ( External Dia. 26 ) ( Internal Dia. 20 )	VP20 ( External Dia. 26 ) ( Internal Dia. 20 )	VP20 ( External Dia. 26 ) ( Internal Dia. 20 )	
Machine Weight (Mass)		kg	18	18	18	
H5 Sound Level (H/L) (230V)		dBA	30/25	30/25	32/26	
Safety Devices			Fuse	Fuse	Fuse	
Refrigerant Control			Electronic Expansion Valve	Electronic Expansion Valve	Electronic Expansion Valve	
Connectable outdoor unit			R410A M Series	R410A M Series	R410A M Series	
Decoration Panels (Option)	Model		BYFQ60BW1	BYFQ60BW1	BYFQ60BW1	
	Panel Color		White (Ral 9010)	White (Ral 9010)	White (Ral 9010)	
	Dimensions: (H×W×D)	mm	55×700×700	55×700×700	55×700×700	
	Air Filter			Resin Net (with Mold Resistant)	Resin Net (with Mold Resistant)	Resin Net (with Mold Resistant)
	Weight	kg	2.7	2.7	2.7	
Standard Accessories			Operation Manual, Installation Manual, Paper Pattern for Installation, Drain Hose, Clamp Metal, Washer Fixing Plate, Sealing Pads, Clamps, Screws, Washer for Hanging Bracket, Insulation for Fitting.	Operation Manual, Installation Manual, Paper Pattern for Installation, Drain Hose, Clamp Metal, Washer Fixing Plate, Sealing Pads, Clamps, Screws, Washer for Hanging Bracket, Insulation for Fitting.	Operation Manual, Installation Manual, Paper Pattern for Installation, Drain Hose, Clamp Metal, Washer Fixing Plate, Sealing Pads, Clamps, Screws, Washer for Hanging Bracket, Insulation for Fitting.	
Drawing No.			3D038929A			

## Notes:

- H1 Indoor temp. : 27°CDB, 19.5°CWB / outdoor temp.: 35°CDB / Equivalent piping length: 7.5m, level difference: 0m.
- H2 Indoor temp. : 27°CDB, 19.0°CWB / outdoor temp.: 35°CDB / Equivalent piping length: 7.5m, level difference: 0m.
- H3 Indoor temp. : 20°CDB / outdoor temp.: 7°CDB, 6°CWB / Equivalent piping length: 7.5m, level difference: 0m. (Heat pump only)
- 4 Capacities are net, including a deduction for cooling (an addition for heating) for indoor fan motor heat.
- H5 Anechoic chamber conversion value, measured under JISB8616 conditions. During actual operation, these values are normally somewhat higher as a result of ambient conditions.

## Conversion Formulae

$$\begin{aligned} \text{kcal/h} &= \text{kW} \times 860 \\ \text{Btu/h} &= \text{kW} \times 3414 \\ \text{cfm} &= \text{m}^3/\text{min} \times 35.3 \end{aligned}$$

## Ceiling Mounted Cassette Type (Multi Flow) 600×600

Model			FXZQ40MVE	FXZQ50MVE
H1 Cooling Capacity (19.5°CWB)		kcal/h	4,000	5,000
		Btu/h	15,900	19,900
		kW	4.7	5.8
H2 Cooling Capacity (19.0°CWB)		kW	4.5	5.6
H3 Heating Capacity		kcal/h	4,300	5,400
		Btu/h	17,000	21,500
		kW	5.0	6.3
Casing			Galvanized Steel Plate	Galvanized Steel Plate
Dimensions: (H×W×D)		mm	260×575×575	260×575×575
Coil (Cross Fin Coil)	Rows×Stages×Fin Pitch	mm	2×10×1.5	2×10×1.5
	Face Area	m <sup>2</sup>	0.269	0.269
Fan	Model		QTS32C15M	QTS32C15M
	Type		Turbo Fan	Turbo Fan
	Motor Output × Number of Units	W	55×1	55×1
	Air Flow Rate (H/L)	m <sup>3</sup> /min	11/8	14/10
		cfm	388/282	494/353
Drive			Direct Drive	Direct Drive
Temperature Control			Microprocessor Thermostat for Cooling and Heating	Microprocessor Thermostat for Cooling and Heating
Sound Absorbing Thermal Insulation Material			Foamed Polystyrene/Foamed Polyethylene	Foamed Polystyrene/Foamed Polyethylene
Piping Connections	Liquid Pipes	mm	φ6.4 (Flare Connection)	φ6.4 (Flare Connection)
	Gas Pipes	mm	φ12.7 (Flare Connection)	φ12.7 (Flare Connection)
	Drain Pipe	mm	VP20 ( External Dia. 26 ) ( Internal Dia. 20 )	VP20 ( External Dia. 26 ) ( Internal Dia. 20 )
Machine Weight (Mass)		kg	18	18
H5 Sound Level (H/L) (230V)		dBA	36/28	41/33
Safety Devices			Fuse	Fuse,
Refrigerant Control			Electronic Expansion Valve	Electronic Expansion Valve
Connectable outdoor unit			R410A M Series	R410A M Series
Decoration Panels (Option)	Model		BYFQ60BW1	BYFQ60BW1
	Panel Color		White (Ral 9010)	White (Ral 9010)
	Dimensions: (H×W×D)	mm	55×700×700	55×700×700
	Air Filter		Resin Net (with Mold Resistant)	Resin Net (with Mold Resistant)
	Weight	kg	2.7	2.7
Standard Accessories			Operation Manual, Installation Manual, Paper Pattern for Installation, Drain Hose, Clamp Metal, Washer Fixing Plate, Sealing Pads, Clamps, Screws, Washer for Hanging Bracket, Insulation for Fitting.	Operation Manual, Installation Manual, Paper Pattern for Installation, Drain Hose, Clamp Metal, Washer Fixing Plate, Sealing Pads, Clamps, Screws, Washer for Hanging Bracket, Insulation for Fitting.
Drawing No.			3D038929A	

## Notes:

- H1 Indoor temp. : 27°CDB, 19.5°CWB / outdoor temp.: 35°CDB / Equivalent piping length: 7.5m, level difference: 0m.
- H2 Indoor temp. : 27°CDB, 19.0°CWB / outdoor temp.: 35°CDB / Equivalent piping length: 7.5m, level difference: 0m.
- H3 Indoor temp. : 20°CDB / outdoor temp.: 7°CDB, 6°CWB / Equivalent piping length; 7.5m, level difference; 0m. (Heat pump only)
- 4 Capacities are net, including a deduction for cooling (an addition for heating) for indoor fan motor heat.
- H5 Anechoic chamber conversion value, measured under JISB8616 conditions. During actual operation, these values are normally somewhat higher as a result of ambient conditions.

## Conversion Formulae

kcal/h=kW×860  
Btu/h=kW×3414  
cfm=m<sup>3</sup>/min×35.3

## Ceiling Mounted Cassette Type (Multi-flow)

Model		FXFQ25MVE	FXFQ32MVE	FXFQ40MVE	FXFQ50MVE	
H1 Cooling Capacity (19.5°CWB)	kcal/h	2,500	3,150	4,000	5,000	
	Btu/h	9,900	12,500	15,900	19,900	
	kW	2.9	3.7	4.7	5.8	
H2 Cooling Capacity (19.0°CWB)	kW	2.8	3.6	4.5	5.6	
H3 Heating Capacity	kcal/h	2,800	3,400	4,300	5,400	
	Btu/h	10,900	13,600	17,000	21,500	
	kW	3.2	4.0	5.0	6.3	
Casing		Galvanized Steel Plate	Galvanized Steel Plate	Galvanized Steel Plate	Galvanized Steel Plate	
Dimensions: (HxWxD)		mm	246x840x840	246x840x840	246x840x840	
Coil (Cross Fin Coil)	RowsxStagesxFin Pitch	mm	2x8x1.2	2x8x1.2	2x8x1.2	
	Face Area	m <sup>2</sup>	0.363	0.363	0.363	
Fan	Model		QTS46D14M	QTS46D14M	QTS46D14M	QTS46D14M
	Type		Turbo Fan	Turbo Fan	Turbo Fan	Turbo Fan
	Motor Output x Number of Units	W	30x1	30x1	30x1	30x1
	Air Flow Rate (H/L)	m <sup>3</sup> /min	13/10	13/10	15/11	16/11
		cfm	459/353	459/353	530/388	565/388
Drive		Direct Drive	Direct Drive	Direct Drive	Direct Drive	
Temperature Control		Microprocessor Thermostat for Cooling and Heating	Microprocessor Thermostat for Cooling and Heating	Microprocessor Thermostat for Cooling and Heating	Microprocessor Thermostat for Cooling and Heating	
Sound Absorbing Thermal Insulation Material		Polyurethane Form	Polyurethane Form	Polyurethane Form	Polyurethane Form	
Piping Connections	Liquid Pipes	mm	φ6.4 (Flare Connection)	φ6.4 (Flare Connection)	φ6.4 (Flare Connection)	φ6.4 (Flare Connection)
	Gas Pipes	mm	φ12.7 (Flare Connection)	φ12.7 (Flare Connection)	φ12.7 (Flare Connection)	φ12.7 (Flare Connection)
	Drain Pipe	mm	VP25 ( External Dia. 32 Internal Dia. 25 )	VP25 ( External Dia. 32 Internal Dia. 25 )	VP25 ( External Dia. 32 Internal Dia. 25 )	VP25 ( External Dia. 32 Internal Dia. 25 )
Machine Weight (Mass)		kg	24	24	24	24
H5 Sound Level (H/L) (220V)		dBA	30/27	30/27	31/27	32/27
Safety Devices			Fuse	Fuse	Fuse	Fuse
Refrigerant Control			Electronic Expansion Valve	Electronic Expansion Valve	Electronic Expansion Valve	Electronic Expansion Valve
Connectable outdoor unit			R410A M Series	R410A M Series	R410A M Series	R410A M Series
Decoration Panels (Option)	Model		BYCP125D-W1	BYCP125D-W1	BYCP125D-W1	BYCP125D-W1
	Panel Color		White (10Y9/0.5)	White (10Y9/0.5)	White (10Y9/0.5)	White (10Y9/0.5)
	Dimensions: (HxWxD)	mm	45x950x950	45x950x950	45x950x950	45x950x950
	Air Filter		Resin Net (with Mold Resistant)	Resin Net (with Mold Resistant)	Resin Net (with Mold Resistant)	Resin Net (with Mold Resistant)
	Weight	kg	5.5	5.5	5.5	5.5
Standard Accessories			Operation manual, Installation manual, Paper pattern for installation, Drain hose, Clamp metal, Washer fixing plate, Sealing pads, Clamps, Screws, Washer for hanging bracket, Insulation for fitting.	Operation manual, Installation manual, Paper pattern for installation, Drain hose, Clamp metal, Washer fixing plate, Sealing pads, Clamps, Screws, Washer for hanging bracket, Insulation for fitting.	Operation manual, Installation manual, Paper pattern for installation, Drain hose, Clamp metal, Washer fixing plate, Sealing pads, Clamps, Screws, Washer for hanging bracket, Insulation for fitting.	Operation manual, Installation manual, Paper pattern for installation, Drain hose, Clamp metal, Washer fixing plate, Sealing pads, Clamps, Screws, Washer for hanging bracket, Insulation for fitting.
Drawing No.			3D038812			

## Notes:

- H1 Indoor temp. : 27°CDB, 19.5°CWB / outdoor temp.: 35°CDB / Equivalent piping length: 7.5m, level difference: 0m.
- H2 Indoor temp. : 27°CDB, 19.0°CWB / outdoor temp.: 35°CDB / Equivalent piping length: 7.5m, level difference: 0m.
- H3 Indoor temp. : 20°CDB / outdoor temp.: 7°CDB, 6°CWB / Equivalent piping length: 7.5m, level difference: 0m. (Heat pump only)
- 4 Capacities are net, including a deduction for cooling (an addition for heating) for indoor fan motor heat.
- H5 Anechoic chamber conversion value, measured under JISB8616 conditions. During actual operation, these values are normally somewhat higher as a result of ambient conditions.

## Conversion Formulae

$$\begin{aligned} \text{kcal/h} &= \text{kW} \times 860 \\ \text{Btu/h} &= \text{kW} \times 3414 \\ \text{cfm} &= \text{m}^3/\text{min} \times 35.3 \end{aligned}$$

**Ceiling Mounted Cassette Type (Multi-flow)**

Model		FXFQ63MVE	FXFQ80MVE	FXFQ100MVE	FXFQ125MVE	
H1 Cooling Capacity (19.5°CWB)	kcal/h	6,300	8,000	10,000	12,500	
	Btu/h	25,000	31,800	39,700	49,600	
	kW	7.3	9.3	11.6	14.5	
H2 Cooling Capacity (19.0°CWB)	kW	7.1	9.0	11.2	14.0	
H3 Heating Capacity	kcal/h	6,900	8,600	10,800	13,800	
	Btu/h	27,300	34,100	42,700	54,600	
	kW	8.0	10.0	12.5	16.0	
Casing		Galvanized Steel Plate	Galvanized Steel Plate	Galvanized Steel Plate	Galvanized Steel Plate	
Dimensions: (HxWxD)		mm	246x840x840	246x840x840	288x840x840	
Coil (Cross Fin Coil)	RowsxStagesxFin Pitch	mm	2x10x1.2	2x10x1.2	2x12x1.2	
	Face Area	m <sup>2</sup>	0.454	0.454	0.544	
Fan	Model		QTS46D14M	QTS46D14M	QTS46C17M	QTS46C17M
	Type		Turbo Fan	Turbo Fan	Turbo Fan	Turbo Fan
	Motor Output x Number of Units	W	30x1	30x1	120x1	120x1
	Air Flow Rate (H/L)	m <sup>3</sup> /min	18.5/14	20/15	26/21	30/24
		cfm	653/494	706/530	918/741	1,059/847
Drive		Direct Drive	Direct Drive	Direct Drive	Direct Drive	
Temperature Control		Microprocessor Thermostat for Cooling and Heating	Microprocessor Thermostat for Cooling and Heating	Microprocessor Thermostat for Cooling and Heating	Microprocessor Thermostat for Cooling and Heating	
Sound Absorbing Thermal Insulation Material		Polyurethane Form	Polyurethane Form	Polyurethane Form	Polyurethane Form	
Piping Connections	Liquid Pipes	mm	φ9.5 (Flare Connection)	φ9.5 (Flare Connection)	φ9.5 (Flare Connection)	φ9.5 (Flare Connection)
	Gas Pipes	mm	φ15.9 (Flare Connection)	φ15.9 (Flare Connection)	φ15.9 (Flare Connection)	φ15.9 (Flare Connection)
	Drain Pipe	mm	VP25 ( External Dia. 32 Internal Dia. 25 )	VP25 ( External Dia. 32 Internal Dia. 25 )	VP25 ( External Dia. 32 Internal Dia. 25 )	VP25 ( External Dia. 32 Internal Dia. 25 )
Machine Weight (Mass)	kg	25	25	29	29	
H5 Sound Level (H/L)	dBA	33/28	36/31	39/33	42/36	
Safety Devices		Fuse	Fuse	Fuse	Fuse	
Refrigerant Control		Electronic Expansion Valve	Electronic Expansion Valve	Electronic Expansion Valve	Electronic Expansion Valve	
Connectable outdoor unit		R410A M Series	R410A M Series	R410A M Series	R410A M Series	
Decoration Panels (Option)	Model		BYCP125D-W1	BYCP125D-W1	BYCP125D-W1	BYCP125D-W1
	Panel Color		White (10Y9/0.5)	White (10Y9/0.5)	White (10Y9/0.5)	White (10Y9/0.5)
	Dimensions: (HxWxD)	mm	45x950x950	45x950x950	45x950x950	45x950x950
	Air Filter		Resin Net (with Mold Resistant)	Resin Net (with Mold Resistant)	Resin Net (with Mold Resistant)	Resin Net (with Mold Resistant)
	Weight	kg	5.5	5.5	5.5	5.5
Standard Accessories		Operation manual, Installation manual, Paper pattern for installation, Drain hose, Clamp metal, Washer fixing plate, Sealing pads, Clamps, Screws, Washer for hanging bracket, Insulation for fitting.	Operation manual, Installation manual, Paper pattern for installation, Drain hose, Clamp metal, Washer fixing plate, Sealing pads, Clamps, Screws, Washer for hanging bracket, Insulation for fitting.	Operation manual, Installation manual, Paper pattern for installation, Drain hose, Clamp metal, Washer fixing plate, Sealing pads, Clamps, Screws, Washer for hanging bracket, Insulation for fitting.	Operation manual, Installation manual, Paper pattern for installation, Drain hose, Clamp metal, Washer fixing plate, Sealing pads, Clamps, Screws, Washer for hanging bracket, Insulation for fitting.	
Drawing No.		3D038812				

**Notes:**

- H1 Indoor temp. : 27°CDB, 19.5°CWB / outdoor temp.: 35°CDB / Equivalent piping length: 7.5m, level difference: 0m.
- H2 Indoor temp. : 27°CDB, 19.0°CWB / outdoor temp.: 35°CDB / Equivalent piping length: 7.5m, level difference: 0m.
- H3 Indoor temp. : 20°CDB / outdoor temp.: 7°CDB, 6°CWB / Equivalent piping length; 7.5m, level difference; 0m. (Heat pump only)
- 4 Capacities are net, including a deduction for cooling (an addition for heating) for indoor fan motor heat.
- H5 Anechoic chamber conversion value, measured under JISB8616 conditions. During actual operation, these values are normally somewhat higher as a result of ambient conditions.

Conversion Formulae
kcal/h=kWx860
Btu/h=kWx3414
cfm=m <sup>3</sup> /minx35.3

## Ceiling Mounted Cassette Corner Type

Model			FXKQ25MVE	FXKQ32MVE	FXKQ40MVE	FXKQ63MVE	
H1 Cooling Capacity (19.5°CWB)		kcal/h	2,500	3,150	4,000	6,300	
		Btu/h	9,900	12,500	15,900	25,000	
		kW	2.9	3.7	4.7	7.3	
H2 Cooling Capacity (19.0°CWB)		kW	2.8	3.6	4.5	7.1	
H3 Heating Capacity		kcal/h	2,800	3,400	4,300	6,900	
		Btu/h	10,900	13,600	17,000	27,300	
		kW	3.2	4.0	5.0	8.0	
Casing			Galvanized Steel Plate	Galvanized Steel Plate	Galvanized Steel Plate	Galvanized Steel Plate	
Dimensions: (HxWxD)		mm	215x1,110x710	215x1,110x710	215x1,110x710	215x1,310x710	
Coil (Cross Fin Coil)	RowsxStagesxFin Pitch	mm	2x11x1.75	2x11x1.75	2x11x1.75	3x11x1.75	
	Face Area	m <sup>2</sup>	0.180	0.180	0.180	0.226	
Fan	Model		3D12H1AN1V1	3D12H1AN1V1	3D12H1AP1V1	4D12H1AJ1V1	
	Type		Sirocco Fan	Sirocco Fan	Sirocco Fan	Sirocco Fan	
	Motor Output x Number of Units	W	15x1	15x1	20x1	45x1	
	Air Flow Rate (H/L)	m <sup>3</sup> /min	11/9	11/9	13/10	18/15	
		cfm	388/318	388/318	459/353	635/530	
Drive			Direct Drive	Direct Drive	Direct Drive	Direct Drive	
Temperature Control			Microprocessor Thermostat for Cooling and Heating	Microprocessor Thermostat for Cooling and Heating	Microprocessor Thermostat for Cooling and Heating	Microprocessor Thermostat for Cooling and Heating	
Sound Absorbing Thermal Insulation Material			Polyethylene Foam	Polyethylene Foam	Polyethylene Foam	Polyethylene Foam	
Piping Connections	Liquid Pipes	mm	φ6.4 (Flare Connection)	φ6.4 (Flare Connection)	φ6.4 (Flare Connection)	φ9.5 (Flare Connection)	
	Gas Pipes	mm	φ12.7 (Flare Connection)	φ12.7 (Flare Connection)	φ12.7 (Flare Connection)	φ15.9 (Flare Connection)	
	Drain Pipe	mm	VP25 ( External Dia. 32 Internal Dia. 25 )	VP25 ( External Dia. 32 Internal Dia. 25 )	VP25 ( External Dia. 32 Internal Dia. 25 )	VP25 ( External Dia. 32 Internal Dia. 25 )	
Machine Weight (Mass)		kg	31	31	31	34	
H5 Sound Level (H/L) (220V)		dBA	38/33	38/33	40/34	42/37	
Safety Devices			Fuse, Thermal Fuse for Fan Motor	Fuse, Thermal Fuse for Fan Motor	Fuse, Thermal Fuse for Fan Motor	Fuse, Thermal Fuse for Fan Motor	
Refrigerant Control			Electronic Expansion Valve	Electronic Expansion Valve	Electronic Expansion Valve	Electronic Expansion Valve	
Connectable Outdoor Units			R410A M Series	R410A M Series	R410A M Series	R410A M Series	
Decoration Panels (Option)	Model		BYK45FJW1	BYK45FJW1	BYK45FJW1	BYK71FJW1	
	Panel Color		White (10Y9/0.5)	White (10Y9/0.5)	White (10Y9/0.5)	White (10Y9/0.5)	
	Dimensions: (HxWxD)	mm	70x1,240x800	70x1,240x800	70x1,240x800	70x1,440x800	
	Air Filter			Resin Net (with Mold Resistant)	Resin Net (with Mold Resistant)	Resin Net (with Mold Resistant)	Resin Net (with Mold Resistant)
	Weight	kg	8.5	8.5	8.5	9.5	
Standard Accessories			Operation Manual, Installation Manual, Paper Pattern for Installation, Drain Hose, Clamp Metal, Insulation for Fitting, Sealing Pads, Clamps, Screws, Washers, Positioning Jig for Installation, Insulation for Hanger Bracket, Air Outlet Blocking Pad.	Operation Manual, Installation Manual, Paper Pattern for Installation, Drain Hose, Clamp Metal, Insulation for Fitting, Sealing Pads, Clamps, Screws, Washers, Positioning Jig for Installation, Insulation for Hanger Bracket, Air Outlet Blocking Pad.	Operation Manual, Installation Manual, Paper Pattern for Installation, Drain Hose, Clamp Metal, Insulation for Fitting, Sealing Pads, Clamps, Screws, Washers, Positioning Jig for Installation, Insulation for Hanger Bracket, Air Outlet Blocking Pad.	Operation Manual, Installation Manual, Paper Pattern for Installation, Drain Hose, Clamp Metal, Insulation for Fitting, Sealing Pads, Clamps, Screws, Washers, Positioning Jig for Installation, Insulation for Hanger Bracket, Air Outlet Blocking Pad.	
Drawing No.			3D038813				

## Notes:

- H1 Indoor temp. : 27°CDB, 19.5°CWB / outdoor temp.: 35°CDB / Equivalent piping length: 7.5m, level difference: 0m.
- H2 Indoor temp. : 27°CDB, 19.0°CWB / outdoor temp.: 35°CDB / Equivalent piping length: 7.5m, level difference: 0m.
- H3 Indoor temp. : 20°CDB / outdoor temp.: 7°CDB, 6°CWB / Equivalent piping length; 7.5m, level difference: 0m. (Heat pump only)
- 4 Capacities are net, including a deduction for cooling (an addition for heating) for indoor fan motor heat.
- H5 Anechoic chamber conversion value, measured at a point 1m in front of the unit and 1m downward. During actual operation, these values are normally somewhat higher as a result of ambient conditions.

## Conversion Formulae

kcal/h=kWx860  
Btu/h=kWx3414  
cfm=m<sup>3</sup>/minx35.3

## Slim Ceiling Mounted Duct Type

Model			FXDQ20NVE	FXDQ25NVE	FXDQ32NVE
H1 Cooling Capacity (19.5°CWB)	kcal/h		2,000	2,500	3,150
	Btu/h		7,900	9,900	12,500
	kW		2.3	2.9	3.7
H2 Cooling Capacity (19.0°CWB)	kW		2.2	2.8	3.6
H3 Heating Capacity	kcal/h		2,200	2,800	3,400
	Btu/h		8,500	10,900	13,600
	kW		2.5	3.2	4.0
Casing			Galvanized Steel Plate	Galvanized Steel Plate	Galvanized Steel Plate
Dimensions: (HxWxD)		mm	200x900x620	200x900x620	200x900x620
Coil (Cross Fin Coil)	RowsxStagesxFin Pitch	mm	2x12x1.5	2x12x1.5	2x12x1.5
	Face Area	m <sup>2</sup>	0.176	0.176	0.176
Fan	Model		—	—	—
	Type		Sirocco Fan	Sirocco Fan	Sirocco Fan
	Motor Output x Number of Units	W	62x1	62x1	62x1
	Air Flow Rate (H/L)	m <sup>3</sup> /min	9.5/7.5	9.5/7.5	10.5/8.5
	External Static Pressure	Pa	44-15 H5	44-15 H5	44-15 H5
	Drive		Direct Drive	Direct Drive	Direct Drive
Temperature Control			Microprocessor Thermostat for Cooling and Heating	Microprocessor Thermostat for Cooling and Heating	Microprocessor Thermostat for Cooling and Heating
Sound Absorbing Thermal Insulation Material			Foamed Polyethylene	Foamed Polyethylene	Foamed Polyethylene
Air Filter			Removal / Washable / Mildew Proof	Removal / Washable / Mildew Proof	Removal / Washable / Mildew Proof
Piping Connections	Liquid Pipes	mm	φ6.4 (Flare Connection)	φ6.4 (Flare Connection)	φ6.4 (Flare Connection)
	Gas Pipes	mm	φ12.7 (Flare Connection)	φ12.7 (Flare Connection)	φ12.7 (Flare Connection)
	Drain Pipe	mm	VP20 (External Dia. 26 Internal Dia. 20)	VP20 (External Dia. 26 Internal Dia. 20)	VP20 (External Dia. 26 Internal Dia. 20)
Machine Weight (Mass)		kg	26	26	26
H6 Sound Level (H/L)		dBA	33/29	33/29	33/29
Safety Devices			Fuse, Thermal Protector for Fan Motor	Fuse, Thermal Protector for Fan Motor	Fuse, Thermal Protector for Fan Motor
Refrigerant Control			Electronic Expansion Valve	Electronic Expansion Valve	Electronic Expansion Valve
Standard Accessories			Operation Manual, Installation Manual, Warranty, Drain Hose, Sealing Pads, Clamps, Washers, Insulation for Fitting, Clamp Metal, Washer Fixing Plate, Screws for Duct Flanges, Air Filter	Operation Manual, Installation Manual, Warranty, Drain Hose, Sealing Pads, Clamps, Washers, Insulation for Fitting, Clamp Metal, Washer Fixing Plate, Screws for Duct Flanges, Air Filter	Operation Manual, Installation Manual, Warranty, Drain Hose, Sealing Pads, Clamps, Washers, Insulation for Fitting, Clamp Metal, Washer Fixing Plate, Screws for Duct Flanges, Air Filter
Drawing No.			3D045744		

## Notes:

- H1 Indoor temp. : 27°CDB, 19.5°CWB / outdoor temp; 35°CDB / Equivalent piping length: 7.5m, level difference: 0m.
- H2 Indoor temp. : 27°CDB, 19.0°CWB / outdoor temp; 35°CDB / Equivalent piping length: 7.5m, level difference: 0m.
- H3 Indoor temp. : 20°CDB / outdoor temp.: 7°CDB, 6°CWB / Equivalent piping length; 7.5m, level difference; 0m. (Heat pump only)
- H4 Capacities are net, including a deduction for cooling (an addition for heating) for indoor fan motor heat.
- H5 External static pressure is changeable to set by the remote controller this pressure means "High static pressure - Standard static pressure".
- H6 The operation sound levels are the conversion values in anechoic chamber. In practice, the sound tend to be larger than the specified values due to ambient noise or reflections.  
When the place of suction is changed to the bottom suction, the sound level will increase by approx. 5dBA.

## Conversion Formulae

kcal/h=kW×860  
Btu/h=kW×3414  
cfm=m<sup>3</sup>/min×35.3

## Slim Ceiling Mounted Duct Type

Model			FXDQ40NVE	FXDQ50NVE	FXDQ63NVE
H1 Cooling Capacity (19.5°CWB)		kcal/h	4,000	5,000	6,300
		Btu/h	15,900	19,900	25,000
		kW	4.7	5.8	7.3
H2 Cooling Capacity (19.0°CWB)		kW	4.5	5.6	7.1
H3 Heating Capacity		kcal/h	4,300	5,400	6,900
		Btu/h	17,000	21,500	27,300
		kW	5.0	6.3	8.0
Casing Color			Galvanized Steel Plate	Galvanized Steel Plate	Galvanized Steel Plate
Dimensions: (HxWxD)		mm	200x900x620	200x900x620	200x1100x620
Coil (Cross Fin Coil)	RowsxStagesxFin Pitch	mm	3x12x1.5	3x12x1.5	3x12x1.5
	Face Area	m <sup>2</sup>	0.176	0.176	0.227
Fan	Model		—		
	Type		Sirocco Fan		
	Motor Output x Number of Units	W	62x1	130x1	130x1
	Air Flow Rate (H/L)	m <sup>3</sup> /min	10.5/8.5	12.5/10.0	16.5/13.0
	External Static Pressure	Pa	44-15 H5	44-15 H5	44-15 H5
	Drive		Direct Drive		
Temperature Control			Microprocessor Thermostat for Cooling and Heating	Microprocessor Thermostat for Cooling and Heating	Microprocessor Thermostat for Cooling and Heating
Sound Absorbing Thermal Insulation Material			Foamed Polyethylene	Foamed Polyethylene	Foamed Polyethylene
Air Filter			Removal / Washable / Mildew Proof	Removal / Washable / Mildew Proof	Removal / Washable / Mildew Proof
Piping Connections	Liquid Pipes	mm	φ6.4 (Flare Connection)	φ6.4 (Flare Connection)	φ9.5 (Flare Connection)
	Gas Pipes	mm	φ12.7 (Flare Connection)	φ12.7 (Flare Connection)	φ15.9 (Flare Connection)
	Drain Pipe	mm	VP20 (External Dia. 26 Internal Dia. 20)	VP20 (External Dia. 26 Internal Dia. 20)	VP20 (External Dia. 26 Internal Dia. 20)
Machine Weight (Mass)		kg	27	28	31
H6 Sound Level (H/L)		dBA	34/30	35/31	36/32
Safety Devices			Fuse, Thermal Protector for Fan Motor	Fuse, Thermal Protector for Fan Motor	Fuse, Thermal Protector for Fan Motor
Refrigerant Control			Electronic Expansion Valve	Electronic Expansion Valve	Electronic Expansion Valve
Standard Accessories			Operation Manual, Installation Manual, Warranty, Drain Hose, Sealing Pads, Clamps, Washers, Insulation for Fitting, Clamp Metal, Washer Fixing Plate, Screws for Duct Flanges, Air Filter	Operation Manual, Installation Manual, Warranty, Drain Hose, Sealing Pads, Clamps, Washers, Insulation for Fitting, Clamp Metal, Washer Fixing Plate, Screws for Duct Flanges, Air Filter	Operation Manual, Installation Manual, Warranty, Drain Hose, Sealing Pads, Clamps, Washers, Insulation for Fitting, Clamp Metal, Washer Fixing Plate, Screws for Duct Flanges, Air Filter
Drawing No.			3D045744		

## Notes:

- H1 Indoor temp. : 27°CDB, 19.5°CWB / outdoor temp; 35°CDB / Equivalent piping length: 7.5m, level difference: 0m.
- H2 Indoor temp. : 27°CDB, 19.0°CWB / outdoor temp; 35°CDB / Equivalent piping length: 7.5m, level difference: 0m.
- H3 Indoor temp. : 20°CDB / outdoor temp.: 7°CDB, 6°CWB / Equivalent piping length; 7.5m, level difference; 0m. (Heat pump only)
- H4 Capacities are net, including a deduction for cooling (an addition for heating) for indoor fan motor heat.
- H5 External static pressure is changeable to set by the remote controller this pressure means "High static pressure - Standard static pressure".
- H6 The operation sound levels are the conversion values in anechoic chamber. In practice, the sound tend to be larger than the specified values due to ambient noise or reflections.  
When the place of suction is changed to the bottom suction, the sound level will increase by approx. 5dBA.

## Conversion Formulae

kcal/h=kW×860  
Btu/h=kW×3414  
cfm=m<sup>3</sup>/min×35.3



## Ceiling Mounted Built-in Type

Model			FXSQ20MVE	FXSQ25MVE	FXSQ32MVE
H1 Cooling Capacity (19.5°CWB)		kcal/h	2,000	2,500	3,150
		Btu/h	7,900	9,900	12,500
		kW	2.3	2.9	3.7
H2 Cooling Capacity (19.0°CWB)		kW	2.2	2.8	3.6
H3 Heating Capacity		kcal/h	2,200	2,800	3,400
		Btu/h	8,500	10,900	13,600
		kW	2.5	3.2	4.0
Casing			Galvanized Steel Plate	Galvanized Steel Plate	Galvanized Steel Plate
Dimensions: (HxWxD)		mm	300x550x800	300x550x800	300x550x800
Coil (Cross Fin Coil)	RowsxStagesxFin Pitch	mm	3x14x1.75	3x14x1.75	3x14x1.75
	Face Area	m <sup>2</sup>	0.088	0.088	0.088
Fan	Model		D18H3A	D18H3A	D18H3A
	Type		Sirocco Fan	Sirocco Fan	Sirocco Fan
	Motor Output x Number of Units	W	50x1	50x1	50x1
	Air Flow Rate (H/L)	m <sup>3</sup> /min	9/6.5	9/6.5	9.5/7
	H4 Static external pressure	Pa	88-39-20	88-39-20	64-39-15
	Drive		Direct Drive	Direct Drive	Direct Drive
Temperature Control			Microprocessor Thermostat for Cooling and Heating	Microprocessor Thermostat for Cooling and Heating	Microprocessor Thermostat for Cooling and Heating
Sound Absorbing Thermal Insulation Material			Glass Fiber	Glass Fiber	Glass Fiber
Air Filter			Resin Net (with Mold Resistant)	Resin Net (with Mold Resistant)	Resin Net (with Mold Resistant)
Piping Connections	Liquid Pipes	mm	φ6.4 (Flare Connection)	φ6.4 (Flare Connection)	φ6.4 (Flare Connection)
	Gas Pipes	mm	φ12.7 (Flare Connection)	φ12.7 (Flare Connection)	φ12.7 (Flare Connection)
	Drain Pipe	mm	VP25 (External Dia. 32 Internal Dia. 25)	VP25 (External Dia. 32 Internal Dia. 25)	VP25 (External Dia. 32 Internal Dia. 25)
Machine Weight (Mass)		kg	30	30	30
H7 Sound Level (H/L) (220V)		dBA	37/32	37/32	38/32
Safety Devices			Fuse, Thermal Protector for Fan Motor	Fuse, Thermal Protector for Fan Motor	Fuse, Thermal Protector for Fan Motor
Refrigerant Control			Electronic Expansion Valve	Electronic Expansion Valve	Electronic Expansion Valve
Connectable outdoor unit			R410A M Series	R410A M Series	R410A M Series
Decoration Panel (Option)	Model		BYBS32DJW1	BYBS32DJW1	BYBS32DJW1
	Panel Color		White (10Y9/0.5)	White (10Y9/0.5)	White (10Y9/0.5)
	Dimensions: (HxWxD)	mm	55x650x500	55x650x500	55x650x500
	Weight	kg	3	3	3
Standard Accessories			Operation Manual, Installation Manual, Paper Pattern for Installation, Drain Hose, Clamp Metal, Insulation for Fitting, Sealing Pads, Clamps, Screws, Washers.	Operation Manual, Installation Manual, Paper Pattern for Installation, Drain Hose, Clamp Metal, Insulation for Fitting, Sealing Pads, Clamps, Screws, Washers.	Operation Manual, Installation Manual, Paper Pattern for Installation, Drain Hose, Clamp Metal, Insulation for Fitting, Sealing Pads, Clamps, Screws, Washers.
Drawing No.			3D039431		

## Notes:

- H1 Indoor temp. : 27°CDB, 19.5°CWB / outdoor temp.: 35°CDB / Equivalent piping length: 7.5m, level difference: 0m.
- H2 Indoor temp. : 27°CDB, 19.0°CWB / outdoor temp.: 35°CDB / Equivalent piping length: 7.5m, level difference: 0m.
- H3 Indoor temp. : 20°CDB / outdoor temp.: 7°CDB, 6°CWB / Equivalent piping length; 7.5m, level difference; 0m. (Heat pump only)
- H4 Static external pressure is changeable to change over the connectors inside electrical box, this pressure means "High static pressure-Standard -Low static pressure".
- H5 Static external pressure is changeable to change over the connectors inside electrical box, this pressure means "High static pressure-Standard".
- 6 Capacities are net, including a deduction for cooling (an additional for heating) for indoor fan motor heat.
- H7 Anechoic chamber conversion value, measured at a point 1.5m downward from the unit center. These values are normally somewhat higher during actual operation as a result of ambient conditions.

## Conversion Formulae

$$\begin{aligned} \text{kcal/h} &= \text{kW} \times 860 \\ \text{Btu/h} &= \text{kW} \times 3414 \\ \text{cfm} &= \text{m}^3/\text{min} \times 35.3 \end{aligned}$$

## Ceiling Mounted Built-in Type

Model			FXSQ40MVE	FXSQ50MVE	FXSQ63MVE
H1 Cooling Capacity (19.5°CWB)		kcal/h	4,000	5,000	6,300
		Btu/h	15,900	19,900	25,000
		kW	4.7	5.8	7.3
H2 Cooling Capacity (19.0°CWB)		kW	4.5	5.6	7.1
H3 Heating Capacity		kcal/h	4,300	5,400	6,900
		Btu/h	17,000	21,500	27,300
		kW	5.0	6.3	8.0
Casing			Galvanized Steel Plate	Galvanized Steel Plate	Galvanized Steel Plate
Dimensions: (HxWxD)		mm	300x700x800	300x700x800	300x1,000x800
Coil (Cross Fin Coil)	RowsxStagesxFin Pitch	mm	3x14x1.75	3x14x1.75	3x14x1.75
	Face Area	m <sup>2</sup>	0.132	0.132	0.221
Fan	Model		D18H2A	D18H2A	2D18H2A
	Type		Sirocco Fan	Sirocco Fan	Sirocco Fan
	Motor Output x Number of Units	W	65x1	85x1	125x1
	Air Flow Rate (H/L)	m <sup>3</sup> /min	11.5/9	15/11	21/15.5
	H4 Static external pressure	Pa	88-49-20	88-59-29	88-49-20
	Drive		Direct Drive	Direct Drive	Direct Drive
Temperature Control			Microprocessor Thermostat for Cooling and Heating	Microprocessor Thermostat for Cooling and Heating	Microprocessor Thermostat for Cooling and Heating
Sound Absorbing Thermal Insulation Material			Glass Fiber	Glass Fiber	Glass Fiber
Air Filter			Resin Net (with Mold Resistant)	Resin Net (with Mold Resistant)	Resin Net (with Mold Resistant)
Piping Connections	Liquid Pipes	mm	φ6.4 (Flare Connection)	φ6.4 (Flare Connection)	φ9.5 (Flare Connection)
	Gas Pipes	mm	φ12.7 (Flare Connection)	φ12.7 (Flare Connection)	φ15.9 (Flare Connection)
	Drain Pipe	mm	VP25 (External Dia. 32 Internal Dia. 25)	VP25 (External Dia. 32 Internal Dia. 25)	VP25 (External Dia. 32 Internal Dia. 25)
Machine Weight (Mass)	kg	30	31	41	
H7 Sound Level (H/L)	dBA	38/32	41/36	42/35	
Safety Devices			Fuse, Thermal Protector for Fan Motor	Fuse, Thermal Protector for Fan Motor	Fuse, Thermal Protector for Fan Motor
Refrigerant Control			Electronic Expansion Valve	Electronic Expansion Valve	Electronic Expansion Valve
Connectable outdoor unit			R410A M Series	R410A M Series	R410A M Series
Decoration Panel (Option)	Model		BYBS45DJW1	BYBS45DJW1	BYBS71DJW1
	Panel Color		White (10Y9/0.5)	White (10Y9/0.5)	White (10Y9/0.5)
	Dimensions: (HxWxD)	mm	55x800x500	55x800x500	55x1,100x500
	Weight	kg	3.5	3.5	4.5
Standard Accessories			Operation Manual, Installation Manual, Paper Pattern for Installation, Drain Hose, Clamp Metal, Insulation for Fitting, Sealing Pads, Clamps, Screws, Washers.	Operation Manual, Installation Manual, Paper Pattern for Installation, Drain Hose, Clamp Metal, Insulation for Fitting, Sealing Pads, Clamps, Screws, Washers.	Operation Manual, Installation Manual, Paper Pattern for Installation, Drain Hose, Clamp Metal, Insulation for Fitting, Sealing Pads, Clamps, Screws, Washers.
Drawing No.			3D039431		

## Notes:

- H1 Indoor temp. : 27°CDB, 19.5°CWB / outdoor temp.: 35°CDB / Equivalent piping length: 7.5m, level difference: 0m.
- H2 Indoor temp. : 27°CDB, 19.0°CWB / outdoor temp.: 35°CDB / Equivalent piping length: 7.5m, level difference: 0m.
- H3 Indoor temp. : 20°CDB / outdoor temp.: 7°CDB, 6°CWB / Equivalent piping length; 7.5m, level difference; 0m. (Heat pump only)
- H4 Static external pressure is changeable to change over the connectors inside electrical box, this pressure means "High static pressure-Standard -Low static pressure".
- H5 Static external pressure is changeable to change over the connectors inside electrical box, this pressure means "High static pressure-Standard".
- 6 Capacities are net, including a deduction for cooling (an additional for heating) for indoor fan motor heat.
- H7 Anechoic chamber conversion value, measured at a point 1.5m downward from the unit center. These values are normally somewhat higher during actual operation as a result of ambient conditions.

## Conversion Formulae

$$\begin{aligned} \text{kcal/h} &= \text{kW} \times 860 \\ \text{Btu/h} &= \text{kW} \times 3414 \\ \text{cfm} &= \text{m}^3/\text{min} \times 35.3 \end{aligned}$$

## Ceiling Mounted Built-in Type

Model		FXSQ80MVE	FXSQ100MVE	FXSQ125MVE
H1 Cooling Capacity (19.5°CWB)	kcal/h	8,000	10,000	12,500
	Btu/h	31,800	39,700	49,600
	kW	9.3	11.6	14.5
H2 Cooling Capacity (19.0°CWB)	kW	9.0	11.2	14.0
H3 Heating Capacity	kcal/h	8,600	10,800	13,800
	Btu/h	34,100	42,700	54,600
	kW	10.0	12.5	16.0
Casing		Galvanized Steel Plate	Galvanized Steel Plate	Galvanized Steel Plate
Dimensions: (HxWxD)		300x1,400x800	300x1,400x800	300x1,400x800
Coil (Cross Fin Coil)	RowsxStagesxFin Pitch	mm	3x14x1.75	3x14x1.75
	Face Area	m <sup>2</sup>	0.338	0.338
Fan	Model		3D18H2A	3D18H2A
	Type		Sirocco Fan	Sirocco Fan
	Motor Output x Number of Units	W	225x1	225x1
	Air Flow Rate (H/L)	m <sup>3</sup> /min	27/21.5	28/22
	H5 Static external pressure	Pa	113-82	107-75
	Drive		Direct Drive	Direct Drive
Temperature Control		Microprocessor Thermostat for Cooling and Heating	Microprocessor Thermostat for Cooling and Heating	Microprocessor Thermostat for Cooling and Heating
Sound Absorbing Thermal Insulation Material		Glass Fiber	Glass Fiber	Glass Fiber
Air Filter		Resin Net (with Mold Resistant)	Resin Net (with Mold Resistant)	Resin Net (with Mold Resistant)
Piping Connections	Liquid Pipes	mm	φ9.5 (Flare Connection)	φ9.5 (Flare Connection)
	Gas Pipes	mm	φ15.9 (Flare Connection)	φ15.9 (Flare Connection)
	Drain Pipe	mm	VP25 (External Dia. 32 Internal Dia. 25)	VP25 (External Dia. 32 Internal Dia. 25)
Machine Weight (Mass)	kg	51	51	52
H7 Sound Level (H/L)	dBA	43/37	43/37	46/41
Safety Devices		Fuse, Thermal Protector for Fan Motor	Fuse, Thermal Protector for Fan Motor	Fuse, Thermal Protector for Fan Motor
Refrigerant Control		Electronic Expansion Valve	Electronic Expansion Valve	Electronic Expansion Valve
Connectable outdoor unit		R410A M Series	R410A M Series	R410A M Series
Decoration Panel (Option)	Model		BYBS125DJW1	BYBS125DJW1
	Panel Color		White (10Y9/0.5)	White (10Y9/0.5)
	Dimensions: (HxWxD)	mm	55x1,500x500	55x1,500x500
	Weight	kg	6.5	6.5
Standard Accessories		Operation Manual, Installation Manual, Paper Pattern for Installation, Drain Hose, Clamp Metal, Insulation for Fitting, Sealing Pads, Clamps, Screws, Washers.	Operation Manual, Installation Manual, Paper Pattern for Installation, Drain Hose, Clamp Metal, Insulation for Fitting, Sealing Pads, Clamps, Screws, Washers.	Operation Manual, Installation Manual, Paper Pattern for Installation, Drain Hose, Clamp Metal, Insulation for Fitting, Sealing Pads, Clamps, Screws, Washers.
Drawing No.		3D039431		

## Notes:

- H1 Indoor temp. : 27°CDB, 19.5°CWB / outdoor temp.: 35°CDB / Equivalent piping length: 7.5m, level difference: 0m.
- H2 Indoor temp. : 27°CDB, 19.0°CWB / outdoor temp.: 35°CDB / Equivalent piping length: 7.5m, level difference: 0m.
- H3 Indoor temp. : 20°CDB / outdoor temp.: 7°CDB, 6°CWB / Equivalent piping length; 7.5m, level difference; 0m. (Heat pump only)
- H4 Static external pressure is changeable to change over the connectors inside electrical box, this pressure means "High static pressure-Standard -Low static pressure".
- H5 Static external pressure is changeable to change over the connectors inside electrical box, this pressure means "High static pressure-Standard".
- 6 Capacities are net, including a deduction for cooling (an additional for heating) for indoor fan motor heat.
- H7 Anechoic chamber conversion value, measured at a point 1.5m downward from the unit center. These values are normally somewhat higher during actual operation as a result of ambient conditions.

## Conversion Formulae

$$\begin{aligned} \text{kcal/h} &= \text{kW} \times 860 \\ \text{Btu/h} &= \text{kW} \times 3414 \\ \text{cfm} &= \text{m}^3/\text{min} \times 35.3 \end{aligned}$$

## Ceiling Mounted Duct Type

Model		FXMQ40MVE	FXMQ50MVE	FXMQ63MVE	FXMQ80MVE	
H1 Cooling Capacity (19.5°CWB)	kcal/h	4,000	5,000	6,300	8,000	
	Btu/h	15,900	19,900	25,000	31,800	
	kW	4.7	5.8	7.3	9.3	
H2 Cooling Capacity (19.0°CWB)	kW	4.5	5.6	7.1	9.0	
H3 Heating Capacity	kcal/h	4,300	5,400	6,900	8,600	
	Btu/h	17,000	21,500	27,300	34,100	
	kW	5.0	6.3	8.0	10.0	
Casing		Galvanized Steel Plate	Galvanized Steel Plate	Galvanized Steel Plate	Galvanized Steel Plate	
Dimensions: (HxWxD)		mm	390x720x690	390x720x690	390x720x690	
Coil (Cross Fin Coil)	RowsxStagesxFin Pitch	mm	3x16x2.0	3x16x2.0	3x16x2.0	
	Face Area	m <sup>2</sup>	0.181	0.181	0.181	
Fan	Model		D11/2D3AB1VE	D11/2D3AB1VE	D11/2D3AB1VE	D11/2D3AA1VE
	Type		Sirocco Fan	Sirocco Fan	Sirocco Fan	Sirocco Fan
	Motor Output x Number of Units	W	100x1	100x1	100x1	160x1
	Air Flow Rate (H/L)	m <sup>3</sup> /min	14/11.5	14/11.5	14/11.5	19.5/16
		cfm	494/406	494/406	494/406	688/565
	External Static Pressure 50 / 60Hz	Pa	157/157-118/108 H4	157/157-118/108 H4	157/157-118/108 H4	157/160-108/98 H4
Drive		Direct Drive	Direct Drive	Direct Drive	Direct Drive	
Temperature Control		Microprocessor Thermostat for Cooling and Heating	Microprocessor Thermostat for Cooling and Heating	Microprocessor Thermostat for Cooling and Heating	Microprocessor Thermostat for Cooling and Heating	
Sound Absorbing Thermal Insulation Material		Glass Fiber	Glass Fiber	Glass Fiber	Glass Fiber	
Air Filter		H5	H5	H5	H5	
Piping Connections	Liquid Pipes	mm	φ6.4 (Flare Connection)	φ6.4 (Flare Connection)	φ9.5 (Flare Connection)	φ9.5 (Flare Connection)
	Gas Pipes	mm	φ12.7 (Flare Connection)	φ12.7 (Flare Connection)	φ15.9 (Flare Connection)	φ15.9 (Flare Connection)
	Drain Pipe	mm	VP25 ( External Dia. 32 ) ( Internal Dia. 25 )	VP25 ( External Dia. 32 ) ( Internal Dia. 25 )	VP25 ( External Dia. 32 ) ( Internal Dia. 25 )	VP25 ( External Dia. 32 ) ( Internal Dia. 25 )
Machine Weight (Mass)	kg	44	44	44	45	
H7 Sound Level (H/L)	dBA	39/35	39/35	39/35	42/38	
Safety Devices		Fuse, Thermal Fuse for Fan Motor	Fuse, Thermal Fuse for Fan Motor	Fuse, Thermal Fuse for Fan Motor	Fuse, Thermal Fuse for Fan Motor	
Refrigerant Control		Electronic Expansion Valve	Electronic Expansion Valve	Electronic Expansion Valve	Electronic Expansion Valve	
Connectable outdoor unit		R410A M Series	R410A M Series	R410A M Series	R410A M Series	
Standard Accessories		Operation Manual, Installation Manual, Drain Hose, Clamp Metal, Insulation for Fitting, Sealing Pads, Clamps, Screws.	Operation Manual, Installation Manual, Drain Hose, Clamp Metal, Insulation for Fitting, Sealing Pads, Clamps, Screws.	Operation Manual, Installation Manual, Drain Hose, Clamp Metal, Insulation for Fitting, Sealing Pads, Clamps, Screws.	Operation Manual, Installation Manual, Drain Hose, Clamp Metal, Insulation for Fitting, Sealing Pads, Clamps, Screws.	
Drawing No.		3D038814				

## Notes:

- H1 Indoor temp. : 27°CDB, 19.5°CWB / outdoor temp.: 35°CDB / Equivalent piping length: 7.5m, level difference: 0m.
- H2 Indoor temp. : 27°CDB, 19.0°CWB / outdoor temp.: 35°CDB / Equivalent piping length: 7.5m, level difference: 0m.
- H3 Indoor temp. : 20°CDB / outdoor temp.: 7°CDB, 6°CWB / Equivalent piping length: 7.5m, level difference: 0m. (Heat pump only)
- H4 Static external pressure is changeable to change over the connectors inside electrical box, this pressure means "High static pressure-Standard".
- H5 Air filter is not standard accessory, but please mount it in the duct system of the suction side. Select its colorimetric method (gravity method) 50% or more.
- 6 Capacities are net, including a deduction for cooling (an addition for heating) for indoor fan motor heat.
- H7 Anechoic chamber conversion value, measured at a point 1.5m downward from the unit center. These values are normally somewhat higher during actual operation as a result of ambient conditions.

Conversion Formulae
kcal/h=kWx860
Btu/h=kWx3414
cfm=m <sup>3</sup> /minx35.3

**Ceiling Mounted Duct Type**

Model		FXMQ100MVE	FXMQ125MVE	FXMQ200MVE	FXMQ250MVE	
H1 Cooling Capacity (19.5°CWB)	kcal/h	10,000	12,500	20,000	25,000	
	Btu/h	39,700	49,600	79,000	99,000	
	kW	11.6	14.5	23.0	28.8	
H2 Cooling Capacity (19.0°CWB)	kW	11.2	14.0	22.4	28.0	
H3 Heating Capacity	kcal/h	10,800	13,800	21,500	27,000	
	Btu/h	42,700	54,600	85,300	107,500	
	kW	12.5	16.0	25.0	31.5	
Casing		Galvanized Steel Plate	Galvanized Steel Plate	Galvanized Steel Plate	Galvanized Steel Plate	
Dimensions: (HxWxD)		mm	390x1,110x690	390x1,110x690	470x1,380x1,100	
Coil (Cross Fin Coil)	RowsxStagesxFin Pitch	mm	3x16x2.0	3x16x2.0	3x26x2.0	
	Face Area	m <sup>2</sup>	0.319	0.319	0.68	
Fan	Model		2D11/2D3AG1VE	2D11/2D3AF1VE	D13/4G2DA1x2	D13/4G2DA1x2
	Type		Sirocco Fan	Sirocco Fan	Sirocco Fan	Sirocco Fan
	Motor Output x Number of Units	W	270x1	430x1	380x2	380x2
	Air Flow Rate (H/L)	m <sup>3</sup> /min	29/23	36/29	58/50	72/62
		cfm	1,024/812	1,271/1,024	2,047/1,765	2,542/2,189
	External Static Pressure 50 / 60Hz	Pa	157/172-98/98 H4	191/245-152/172 H4	221/270-132 H4	270/191-147 H4
Drive		Direct Drive	Direct Drive	Direct Drive	Direct Drive	
Temperature Control		Microprocessor Thermostat for Cooling and Heating	Microprocessor Thermostat for Cooling and Heating	Microprocessor Thermostat for Cooling and Heating	Microprocessor Thermostat for Cooling and Heating	
Sound Absorbing Thermal Insulation Material		Glass Fiber	Glass Fiber	Glass Fiber	Glass Fiber	
Air Filter		H5	H5	H5	H5	
Piping Connections	Liquid Pipes	mm	φ9.5 (Flare Connection)	φ9.5 (Flare Connection)	φ9.5 (Flare Connection)	φ9.5 (Flare Connection)
	Gas Pipes	mm	φ15.9 (Flare Connection)	φ15.9 (Flare Connection)	φ19.1 (Brazing Connection)	φ22.2 (Brazing Connection)
	Drain Pipe	mm	VP25 ( External Dia. 32 Internal Dia. 25 )	VP25 ( External Dia. 32 Internal Dia. 25 )	PS1B	PS1B
Machine Weight (Mass)	kg	63	65	137	137	
H7 Sound Level (H/L)	dBA	43/39	45/42	48/45	48/45	
Safety Devices		Fuse, Thermal Fuse for Fan Motor	Fuse, Thermal Fuse for Fan Motor	Fuse, Thermal Protector for Fan Motor	Fuse, Thermal Protector for Fan Motor	
Refrigerant Control		Electronic Expansion Valve	Electronic Expansion Valve	Electronic Expansion Valve	Electronic Expansion Valve	
Connectable outdoor unit		R410A M Series	R410A M Series	R410A M Series	R410A M Series	
Standard Accessories		Operation Manual, Installation Manual, Drain Hose, Clamp Metal, Insulation for Fitting, Sealing Pads, Clamps, Screws.	Operation Manual, Installation Manual, Drain Hose, Clamp Metal, Insulation for Fitting, Sealing Pads, Clamps, Screws.	Operation Manual, Installation Manual, Sealing Pads, Connection Pipes, Screws, Clamps.	Operation Manual, Installation Manual, Sealing Pads, Connection Pipes, Screws, Clamps.	
Drawing No.		3D038814				

**Notes:**

- H1 Indoor temp. : 27°CDB, 19.5°CWB / outdoor temp.: 35°CDB / Equivalent piping length: 7.5m, level difference: 0m.
- H2 Indoor temp. : 27°CDB, 19.0°CWB / outdoor temp.: 35°CDB / Equivalent piping length: 7.5m, level difference: 0m.
- H3 Indoor temp. : 20°CDB / outdoor temp.: 7°CDB, 6°CWB / Equivalent piping length: 7.5m, level difference: 0m. (Heat pump only)
- H4 Static external pressure is changeable to change over the connectors inside electrical box, this pressure means "High static pressure-Standard".
- H5 Air filter is not standard accessory, but please mount it in the duct system of the suction side. Select its colorimetric method (gravity method) 50% or more.
- 6 Capacities are net, including a deduction for cooling (an addition for heating) for indoor fan motor heat.
- H7 Anechoic chamber conversion value, measured at a point 1.5m downward from the unit center. These values are normally somewhat higher during actual operation as a result of ambient conditions.

Conversion Formulae
kcal/h=kWx860
Btu/h=kWx3414
cfm=m <sup>3</sup> /minx35.3

## Ceiling Suspended Type

Model		FXHQ32MVE	FXHQ63MVE	FXHQ100MVE	
H1 Cooling Capacity (19.5°CWB)	kcal/h	3,150	6,300	10,000	
	Btu/h	12,500	25,000	39,700	
	kW	3.7	7.3	11.6	
H2 Cooling Capacity (19.0°CWB)	kW	3.6	7.1	11.2	
H3 Heating Capacity	kcal/h	3,400	6,900	10,800	
	Btu/h	13,600	27,300	42,700	
	kW	4.0	8.0	12.5	
Casing Color		White (10Y9/0.5)	White (10Y9/0.5)	White (10Y9/0.5)	
Dimensions: (HxWxD)		mm	195x960x680	195x1,160x680	195x1,400x680
Coil (Cross Fin Coil)	RowsxStagesxFin Pitch	mm	2x12x1.75	3x12x1.75	3x12x1.75
	Face Area	m <sup>2</sup>	0.182	0.233	0.293
Fan	Model		3D12K1AA1	4D12K1AA1	3D12K2AA1
	Type		Sirocco Fan	Sirocco Fan	Sirocco Fan
	Motor Output x Number of Units	W	62x1	62x1	130x1
	Air Flow Rate (H/L)	m <sup>3</sup> /min	12/10	17.5/14	25/19.5
		cfm	424/353	618/494	883/688
Drive		Direct Drive	Direct Drive	Direct Drive	
Temperature Control		Microprocessor Thermostat for Cooling and Heating	Microprocessor Thermostat for Cooling and Heating	Microprocessor Thermostat for Cooling and Heating	
Sound Absorbing Thermal Insulation Material		Glass Wool	Glass Wool	Glass Wool	
Air Filter		Resin Net (with Mold Resistant)	Resin Net (with Mold Resistant)	Resin Net (with Mold Resistant)	
Piping Connections	Liquid Pipes	mm	φ6.4 (Flare Connection)	φ9.5 (Flare Connection)	φ9.5 (Flare Connection)
	Gas Pipes	mm	φ12.7 (Flare Connection)	φ15.9 (Flare Connection)	φ15.9 (Flare Connection)
	Drain Pipe	mm	VP20 (External Dia. 26 Internal Dia. 20)	VP20 (External Dia. 26 Internal Dia. 20)	VP20 (External Dia. 26 Internal Dia. 20)
Machine Weight (Mass)		kg	24	28	33
H5 Sound Level (H/L)		dBA	36/31	39/34	45/37
Safety Devices		Fuse, Thermal Protector for Fan Motor	Fuse, Thermal Protector for Fan Motor	Fuse, Thermal Protector for Fan Motor	
Refrigerant Control		Electronic Expansion Valve	Electronic Expansion Valve	Electronic Expansion Valve	
Connectable outdoor unit		R410A M Series	R410A M Series	R410A M Series	
Standard Accessories		Operation Manual, Installation Manual, Paper Pattern for Installation, Drain Hose, Clamp Metal, Insulation for Fitting, Clamps, Washers.	Operation Manual, Installation Manual, Paper Pattern for Installation, Drain Hose, Clamp Metal, Insulation for Fitting, Clamps, Washers.	Operation Manual, Installation Manual, Paper Pattern for Installation, Drain Hose, Clamp Metal, Insulation for Fitting, Clamps, Washers.	
Drawing No.		3D038815			

## Notes:

- H1 Indoor temp. : 27°CDB, 19.5°CWB / outdoor temp.: 35°CDB / Equivalent piping length: 7.5m, level difference: 0m.
- H2 Indoor temp. : 27°CDB, 19.0°CWB / outdoor temp.: 35°CDB / Equivalent piping length: 7.5m, level difference: 0m.
- H3 Indoor temp. : 20°CDB / outdoor temp.: 7°CDB, 6°CWB / Equivalent piping length: 7.5m, level difference: 0m. (Heat pump only)
- 4 Capacities are net, including a deduction for cooling (an addition for heating) for indoor fan motor heat.
- H5 Anechoic chamber conversion value, measured under JISB8616 conditions. During actual operation, these values are normally somewhat higher as a result of ambient conditions.

## Conversion Formulae

kcal/h=kWx860  
Btu/h=kWx3414  
cfm=m<sup>3</sup>/minx35.3

## Wall Mounted Type

Model			FXAQ20MVE	FXAQ25MVE	FXAQ32MVE	
H1 Cooling Capacity (19.5°CWB)	kcal/h		2,000	2,500	3,150	
	Btu/h		7,900	9,900	12,500	
	kW		2.3	2.9	3.7	
H2 Cooling Capacity (19.0°CWB)	kW		2.2	2.8	3.6	
H3 Heating Capacity	kcal/h		2,200	2,800	3,400	
	Btu/h		8,500	10,900	13,600	
	kW		2.5	3.2	4.0	
Casing Color			White (3.0Y8.5/10.5)	White (3.0Y8.5/10.5)	White (3.0Y8.5/10.5)	
Dimensions: (HxWxD)		mm	290x795x230	290x795x230	290x795x230	
Coil (Cross Fin Coil)	RowsxStagesxFin Pitch	mm	2x14x1.4	2x14x1.4	2x14x1.4	
	Face Area	m <sup>2</sup>	0.161	0.161	0.161	
Fan	Model		QCL9661M	QCL9661M	QCL9661M	
	Type		Cross Flow Fan	Cross Flow Fan	Cross Flow Fan	
	Motor Output x Number of Units	W	40x1	40x1	40x1	
	Air Flow Rate (H/L)	m <sup>3</sup> /min		7.5/4.5	8/5	9/5.5
		cfm		265/159	282/177	318/194
Drive			Direct Drive	Direct Drive	Direct Drive	
Temperature Control			Microprocessor Thermostat for Cooling and Heating	Microprocessor Thermostat for Cooling and Heating	Microprocessor Thermostat for Cooling and Heating	
Sound Absorbing Thermal Insulation Material			Foamed Polystyrene / Foamed Polyethylene	Foamed Polystyrene / Foamed Polyethylene	Foamed Polystyrene / Foamed Polyethylene	
Air Filter			Resin Net (Washable)	Resin Net (Washable)	Resin Net (Washable)	
Piping Connections	Liquid Pipes	mm	φ6.4 (Flare Connection)	φ6.4 (Flare Connection)	φ6.4 (Flare Connection)	
	Gas Pipes	mm	φ12.7 (Flare Connection)	φ12.7 (Flare Connection)	φ12.7 (Flare Connection)	
	Drain Pipe	mm	VP13 (External Dia. 18 Internal Dia. 13)	VP13 (External Dia. 18 Internal Dia. 13)	VP13 (External Dia. 18 Internal Dia. 13)	
Machine Weight (Mass)	kg		11	11	11	
H5 Sound Level (H/L)	dBA		35/29	36/29	37/29	
Safety Devices			Fuse	Fuse	Fuse	
Refrigerant Control			Electronic Expansion Valve	Electronic Expansion Valve	Electronic Expansion Valve	
Connectable outdoor unit			R410A M Series	R410A M Series	R410A M Series	
Standard Accessories			Operation Manual, Installation Manual, Installation Panel, Paper Pattern for Installation, Insulation Tape, Clamps, screws.	Operation Manual, Installation Manual, Installation Panel, Paper Pattern for Installation, Insulation Tape, Clamps, screws.	Operation Manual, Installation Manual, Installation Panel, Paper Pattern for Installation, Insulation Tape, Clamps, screws.	
Drawing No.			3D039370A			

## Notes:

- H1 Indoor temp. : 27°CDB, 19.5°CWB / outdoor temp.: 35°CDB / Equivalent piping length: 7.5m, level difference: 0m.
- H2 Indoor temp. : 27°CDB, 19.0°CWB / outdoor temp.: 35°CDB / Equivalent piping length: 7.5m, level difference: 0m.
- H3 Indoor temp. : 20°CDB / outdoor temp.: 7°CDB, 6°CWB / Equivalent piping length: 7.5m, level difference: 0m. (Heat pump only)
- 4 Capacities are net, including a deduction for cooling (an addition for heating) for indoor fan motor heat.
- H5 Anechoic chamber conversion value, measured under JISB8616 conditions. During actual operation, these values are normally somewhat higher as a result of ambient conditions.

## Conversion Formulae

$$\begin{aligned} \text{kcal/h} &= \text{kW} \times 860 \\ \text{Btu/h} &= \text{kW} \times 3414 \\ \text{cfm} &= \text{m}^3/\text{min} \times 35.3 \end{aligned}$$

## Wall Mounted Type

Model			FXAQ40MVE	FXAQ50MVE	FXAQ63MVE	
H1 Cooling Capacity (19.5°CWB)	kcal/h		4,000	5,000	6,300	
	Btu/h		15,900	19,900	25,000	
	kW		4.7	5.8	7.3	
H2 Cooling Capacity (19.0°CWB)	kW		4.5	5.6	7.1	
H3 Heating Capacity	kcal/h		4,300	5,400	6,900	
	Btu/h		17,000	21,500	27,300	
	kW		5.0	6.3	8.0	
Casing Color			White (3.0Y8.5/10.5)	White (3.0Y8.5/10.5)	White (3.0Y8.5/10.5)	
Dimensions: (HxWxD)		mm	290x1,050x230	290x1,050x230	290x1,050x230	
Coil (Cross Fin Coil)	RowsxStagesxFin Pitch	mm	2x14x1.4	2x14x1.4	2x14x1.4	
	Face Area	m <sup>2</sup>	0.213	0.213	0.213	
Fan	Model		QCL9686M	QCL9686M	QCL9686M	
	Type		Cross Flow Fan	Cross Flow Fan	Cross Flow Fan	
	Motor Output x Number of Units	W	43x1	43x1	43x1	
	Air Flow Rate (H/L)	m <sup>3</sup> /min		12/9	15/12	19/14
		cfm		424/318	530/424	671/494
Drive			Direct Drive	Direct Drive	Direct Drive	
Temperature Control			Microprocessor Thermostat for Cooling and Heating	Microprocessor Thermostat for Cooling and Heating	Microprocessor Thermostat for Cooling and Heating	
Sound Absorbing Thermal Insulation Material			Foamed Polystyrene / Foamed Polyethylene	Foamed Polystyrene / Foamed Polyethylene	Foamed Polystyrene / Foamed Polyethylene	
Air Filter			Resin Net (Washable)	Resin Net (Washable)	Resin Net (Washable)	
Piping Connections	Liquid Pipes	mm	φ6.4 (Flare Connection)	φ6.4 (Flare Connection)	φ9.5 (Flare Connection)	
	Gas Pipes	mm	φ12.7 (Flare Connection)	φ12.7 (Flare Connection)	φ15.9 (Flare Connection)	
	Drain Pipe	mm	VP13 (External Dia. 18 Internal Dia. 13)	VP13 (External Dia. 18 Internal Dia. 13)	VP13 (External Dia. 18 Internal Dia. 13)	
Machine Weight (Mass)	kg		14	14	14	
H5 Sound Level (H/L)	dBA		39/34	42/36	46/39	
Safety Devices			Fuse	Fuse	Fuse	
Refrigerant Control			Electronic Expansion Valve	Electronic Expansion Valve	Electronic Expansion Valve	
Connectable outdoor unit			R410A M Series	R410A M Series	R410A M Series	
Standard Accessories			Operation Manual, Installation Manual, Installation Panel, Paper Pattern for Installation, Insulation Tape, Clamps, screws.	Operation Manual, Installation Manual, Installation Panel, Paper Pattern for Installation, Insulation Tape, Clamps, screws.	Operation Manual, Installation Manual, Installation Panel, Paper Pattern for Installation, Insulation Tape, Clamps, screws.	
Drawing No.			3D039370A			

## Notes:

- H1 Indoor temp. : 27°CDB, 19.5°CWB / outdoor temp; 35°CDB / Equivalent piping length: 7.5m, level difference: 0m.
- H2 Indoor temp. : 27°CDB, 19.0°CWB / outdoor temp; 35°CDB / Equivalent piping length: 7.5m, level difference: 0m.
- H3 Indoor temp. : 20°CDB / outdoor temp.: 7°CDB, 6°CWB / Equivalent piping length; 7.5m, level difference; 0m. (Heat pump only)
- 4 Capacities are net, including a deduction for cooling (an addition for heating) for indoor fan motor heat.
- H5 Anechoic chamber conversion value, measured under JISB8616 conditions. During actual operation, these values are normally somewhat higher as a result of ambient conditions.

## Conversion Formulae

kcal/h=kWx860  
Btu/h=kWx3414  
cfm=m<sup>3</sup>/minx35.3



## Floor Standing Type

Model			FXLQ20MVE	FXLQ25MVE	FXLQ32MVE
H1 Cooling Capacity (19.5°CWB)		kcal/h	2,000	2,500	3,150
		Btu/h	7,900	9,900	12,500
		kW	2.3	2.9	3.7
H2 Cooling Capacity (19.0°CWB)		kW	2.2	2.8	3.6
H3 Heating Capacity		kcal/h	2,200	2,800	3,400
		Btu/h	8,500	10,900	13,600
		kW	2.5	3.2	4.0
Casing Color			Ivory White (5Y7.5/1)	Ivory White (5Y7.5/1)	Ivory White (5Y7.5/1)
Dimensions: (HxWxD)		mm	600x1,000x222	600x1,000x222	600x1,140x222
Coil (Cross Fin Coil)	RowsxStagesxFin Pitch	mm	3x14x1.5	3x14x1.5	3x14x1.5
	Face Area	m <sup>2</sup>	0.159	0.159	0.200
Fan	Model		D14B20	D14B20	2D14B13
	Type		Sirocco Fan	Sirocco Fan	Sirocco Fan
	Motor Output x Number of Units	W	15x1	15x1	25x1
	Air Flow Rate (H/L)	m <sup>3</sup> /min	7/6	7/6	8/6
		cfm	247/212	247/212	282/212
Drive			Direct Drive	Direct Drive	Direct Drive
Temperature Control			Microprocessor Thermostat for Cooling and Heating	Microprocessor Thermostat for Cooling and Heating	Microprocessor Thermostat for Cooling and Heating
Sound Absorbing Thermal Insulation Material			Glass Fiber/ Urethane Foam	Glass Fiber/ Urethane Foam	Glass Fiber/ Urethane Foam
Air Filter			Resin Net (with Mold Resistant)	Resin Net (with Mold Resistant)	Resin Net (with Mold Resistant)
Piping Connections	Liquid Pipes	mm	φ6.4 (Flare Connection)	φ6.4 (Flare Connection)	φ6.4 (Flare Connection)
	Gas Pipes	mm	φ12.7 (Flare Connection)	φ12.7 (Flare Connection)	φ12.7 (Flare Connection)
	Drain Pipe	mm	φ21 O.D (Vinyl Chloride)	φ21 O.D (Vinyl Chloride)	φ21 O.D (Vinyl Chloride)
Machine Weight (Mass)	kg	25	25	30	
H5 Sound Level (H/L)	dBA	35/32	35/32	35/32	
Safety Devices			Fuse, Thermal Protector for Fan Motor	Fuse, Thermal Protector for Fan Motor	Fuse, Thermal Protector for Fan Motor
Refrigerant Control			Electronic Expansion Valve	Electronic Expansion Valve	Electronic Expansion Valve
Connectable Outdoor Unit			R410A M Series	R410A M Series	R410A M Series
Standard Accessories			Operation Manual, Installation Manual, Insulation for Fitting, Drain Hose, Clamps, Screws, Washers, Level Adjustment Screw.	Operation Manual, Installation Manual, Insulation for Fitting, Drain Hose, Clamps, Screws, Washers, Level Adjustment Screw.	Operation Manual, Installation Manual, Insulation for Fitting, Drain Hose, Clamps, Screws, Washers, Level Adjustment Screw.
Drawing No.			3D038816		

## Notes:

- H1 Indoor temp. : 27°CDB, 19.5°CWB / outdoor temp.: 35°CDB / Equivalent piping length: 7.5m, level difference: 0m.
- H2 Indoor temp. : 27°CDB, 19.0°CWB / outdoor temp.: 35°CDB / Equivalent piping length: 7.5m, level difference: 0m.
- H3 Indoor temp. : 20°CDB / outdoor temp.: 7°CDB, 6°CWB / Equivalent piping length: 7.5m, level difference: 0m. (Heat pump only)
- 4 Capacities are net, including a deduction for cooling (an addition for heating) for indoor fan motor heat.
- H5 Anechoic chamber conversion value, measured at a point 1.5 m in front of the unit at a height of 1.5 m. During actual operation, these values are normally somewhat higher as a result of ambient conditions.

## Conversion Formulae

kcal/h=kWx860  
Btu/h=kWx3414  
cfm=m<sup>3</sup>/minx35.3

## Floor Standing Type

Model			FXLQ40MVE	FXLQ50MVE	FXLQ63MVE
H1 Cooling Capacity (19.5°CWB)		kcal/h	4,000	5,000	6,300
		Btu/h	15,900	19,900	25,000
		kW	4.7	5.8	7.3
H2 Cooling Capacity (19.0°CWB)		kW	4.5	5.6	7.1
H3 Heating Capacity		kcal/h	4,300	5,400	6,900
		Btu/h	17,000	21,500	27,300
		kW	5.0	6.3	8.0
Casing Color			Ivory White (5Y7.5/1)	Ivory White (5Y7.5/1)	Ivory White (5Y7.5/1)
Dimensions: (HxWxD)		mm	600x1,140x222	600x1,420x222	600x1,420x222
Coil (Cross Fin Coil)	RowsxStagesxFin Pitch	mm	3x14x1.5	3x14x1.5	3x14x1.5
	Face Area	m <sup>2</sup>	0.200	0.282	0.282
Fan	Model		2D14B13	2D14B20	2D14B20
	Type		Sirocco Fan	Sirocco Fan	Sirocco Fan
	Motor Output x Number of Units	W	25x1	35x1	35x1
	Air Flow Rate (H/L)	m <sup>3</sup> /min	11/8.5	14/11	16/12
		cfm	388/300	494/388	565/424
Drive			Direct Drive	Direct Drive	Direct Drive
Temperature Control			Microprocessor Thermostat for Cooling and Heating	Microprocessor Thermostat for Cooling and Heating	Microprocessor Thermostat for Cooling and Heating
Sound Absorbing Thermal Insulation Material			Glass Fiber/ Urethane Foam	Glass Fiber/ Urethane Foam	Glass Fiber/ Urethane Foam
Air Filter			Resin Net (with Mold Resistant)	Resin Net (with Mold Resistant)	Resin Net (with Mold Resistant)
Piping Connections	Liquid Pipes	mm	φ6.4 (Flare Connection)	φ6.4 (Flare Connection)	φ9.5 (Flare Connection)
	Gas Pipes	mm	φ12.7 (Flare Connection)	φ12.7 (Flare Connection)	φ15.9 (Flare Connection)
	Drain Pipe	mm	φ21 O.D (Vinyl Chloride)	φ21 O.D (Vinyl Chloride)	φ21 O.D (Vinyl Chloride)
Machine Weight (Mass)	kg	30	36	36	
H5 Sound Level (H/L)	dBA	38/33	39/34	40/35	
Safety Devices			Fuse, Thermal Protector for Fan Motor	Fuse, Thermal Protector for Fan Motor	Fuse, Thermal Protector for Fan Motor
Refrigerant Control			Electronic Expansion Valve	Electronic Expansion Valve	Electronic Expansion Valve
Connectable Outdoor Unit			R410A M Series	R410A M Series	R410A M Series
Standard Accessories			Operation Manual, Installation Manual, Insulation for Fitting, Drain Hose, Clamps, Screws, Washers, Level Adjustment Screw.	Operation Manual, Installation Manual, Insulation for Fitting, Drain Hose, Clamps, Screws, Washers, Level Adjustment Screw.	Operation Manual, Installation Manual, Insulation for Fitting, Drain Hose, Clamps, Screws, Washers, Level Adjustment Screw.
Drawing No.			3D038816		

## Notes:

- H1 Indoor temp. : 27°CDB, 19.5°CWB / outdoor temp.: 35°CDB / Equivalent piping length: 7.5m, level difference: 0m.
- H2 Indoor temp. : 27°CDB, 19.0°CWB / outdoor temp.: 35°CDB / Equivalent piping length: 7.5m, level difference: 0m.
- H3 Indoor temp. : 20°CDB / outdoor temp.: 7°CDB, 6°CWB / Equivalent piping length: 7.5m, level difference: 0m. (Heat pump only)
- 4 Capacities are net, including a deduction for cooling (an addition for heating) for indoor fan motor heat.
- H5 Anechoic chamber conversion value, measured at a point 1.5 m in front of the unit at a height of 1.5 m. During actual operation, these values are normally somewhat higher as a result of ambient conditions.

## Conversion Formulae

kcal/h=kWx860  
Btu/h=kWx3414  
cfm=m<sup>3</sup>/minx35.3

**Concealed Floor Standing Type**

Model			FXNQ20MVE	FXNQ25MVE	FXNQ32MVE
H1 Cooling Capacity (19.5°CWB)		kcal/h	2,000	2,500	3,150
		Btu/h	7,900	9,900	12,500
		kW	2.3	2.9	3.7
H2 Cooling Capacity (19.0°CWB)		kW	2.2	2.8	3.6
H3 Heating Capacity		kcal/h	2,200	2,800	3,400
		Btu/h	8,500	10,900	13,600
		kW	2.5	3.2	4.0
Casing Color			Galvanized Steel Plate	Galvanized Steel Plate	Galvanized Steel Plate
Dimensions: (HxWxD)		mm	610x930x220	610x930x220	610x1,070x220
Coil (Cross Fin Coil)	RowsxStagesxFin Pitch	mm	3x14x1.5	3x14x1.5	3x14x1.5
	Face Area	m <sup>2</sup>	0.159	0.159	0.200
Fan	Model		D14B20	D14B20	2D14B13
	Type		Sirocco Fan	Sirocco Fan	Sirocco Fan
	Motor Output x Number of Units	W	15x1	15x1	25x1
	Air Flow Rate (H/L)	m <sup>3</sup> /min	7/6	7/6	8/6
		cfm	247/212	247/212	282/212
Drive			Direct Drive	Direct Drive	Direct Drive
Temperature Control			Microprocessor Thermostat for Cooling and Heating	Microprocessor Thermostat for Cooling and Heating	Microprocessor Thermostat for Cooling and Heating
Sound Absorbing Thermal Insulation Material			Glass Fiber/ Urethane Foam	Glass Fiber/ Urethane Foam	Glass Fiber/ Urethane Foam
Air Filter			Resin Net (with Mold Resistant)	Resin Net (with Mold Resistant)	Resin Net (with Mold Resistant)
Piping Connections	Liquid Pipes	mm	φ6.4 (Flare Connection)	φ6.4 (Flare Connection)	φ6.4 (Flare Connection)
	Gas Pipes	mm	φ12.7 (Flare Connection)	φ12.7 (Flare Connection)	φ12.7 (Flare Connection)
	Drain Pipe	mm	φ21 O.D (Vinyl Chloride)	φ21 O.D (Vinyl Chloride)	φ21 O.D (Vinyl Chloride)
Machine Weight (Mass)		kg	19	19	23
H5 Sound Level (H/L)		dBA	35/32	35/32	35/32
Safety Devices			Fuse, Thermal Protector for Fan Motor	Fuse, Thermal Protector for Fan Motor	Fuse, Thermal Protector for Fan Motor
Refrigerant Control			Electronic Expansion Valve	Electronic Expansion Valve	Electronic Expansion Valve
Connectable Outdoor Unit			R410A M Series	R410A M Series	R410A M Series
Standard Accessories			Operation Manual, Installation Manual, Insulation for Fitting, Drain Hose, Clamps, Screws, Washers, Level Adjustment Screw.	Operation Manual, Installation Manual, Insulation for Fitting, Drain Hose, Clamps, Screws, Washers, Level Adjustment Screw.	Operation Manual, Installation Manual, Insulation for Fitting, Drain Hose, Clamps, Screws, Washers, Level Adjustment Screw.
Drawing No.			3D038817		

**Notes:**

- H1 Indoor temp. : 27°CDB, 19.5°CWB / outdoor temp.: 35°CDB / Equivalent piping length: 7.5m, level difference: 0m.
- H2 Indoor temp. : 27°CDB, 19.0°CWB / outdoor temp.: 35°CDB / Equivalent piping length: 7.5m, level difference: 0m.
- H3 Indoor temp. : 20°CDB / outdoor temp.: 7°CDB, 6°CWB / Equivalent piping length: 7.5m, level difference: 0m. (Heat pump only)
- 4 Capacities are net, including a deduction for cooling (an addition for heating) for indoor fan motor heat.
- H5 Anechoic chamber conversion value, measured at a point 1.5 m in front of the unit at a height of 1.5 m. During actual operation, these values are normally somewhat higher as a result of ambient conditions.

Conversion Formulae
kcal/h=kWx860
Btu/h=kWx3414
cfm=m <sup>3</sup> /minx35.3

## Concealed Floor Standing Type

Model			FXNQ40MVE	FXNQ50MVE	FXNQ63MVE
H1 Cooling Capacity (19.5°CWB)		kcal/h	4,000	5,000	6,300
		Btu/h	15,900	19,900	25,000
		kW	4.7	5.8	7.3
H2 Cooling Capacity (19.0°CWB)		kW	4.5	5.6	7.1
H3 Heating Capacity		kcal/h	4,300	5,400	6,900
		Btu/h	17,000	21,500	27,300
		kW	5.0	6.3	8.0
Casing Color			Galvanized Steel Plate	Galvanized Steel Plate	Galvanized Steel Plate
Dimensions: (HxWxD)		mm	610x1,070x220	610x1,350x220	610x1,350x220
Coil (Cross Fin Coil)	RowsxStagesxFin Pitch	mm	3x14x1.5	3x14x1.5	3x14x1.5
	Face Area	m <sup>2</sup>	0.200	0.282	0.282
Fan	Model		2D14B13	2D14B20	2D14B20
	Type		Sirocco Fan	Sirocco Fan	Sirocco Fan
	Motor Output x Number of Units	W	25x1	35x1	35x1
	Air Flow Rate (H/L)	m <sup>3</sup> /min	11/8.5	14/11	16/12
		cfm	388/300	494/388	565/424
Drive			Direct Drive	Direct Drive	Direct Drive
Temperature Control			Microprocessor Thermostat for Cooling and Heating	Microprocessor Thermostat for Cooling and Heating	Microprocessor Thermostat for Cooling and Heating
Sound Absorbing Thermal Insulation Material			Glass Fiber / Urethane Foam	Glass Fiber / Urethane Foam	Glass Fiber / Urethane Foam
Air Filter			Resin Net (with Mold Resistant)	Resin Net (with Mold Resistant)	Resin Net (with Mold Resistant)
Piping Connections	Liquid Pipes	mm	φ6.4 (Flare Connection)	φ6.4 (Flare Connection)	φ9.5 (Flare Connection)
	Gas Pipes	mm	φ12.7 (Flare Connection)	φ12.7 (Flare Connection)	φ15.9 (Flare Connection)
	Drain Pipe	mm	φ21 O.D (Vinyl Chloride)	φ21 O.D (Vinyl Chloride)	φ21 O.D (Vinyl Chloride)
Machine Weight (Mass)		kg	23	27	27
H5 Sound Level (H/L)		dBA	38/33	39/34	40/35
Safety Devices			Fuse, Thermal Protector for Fan Motor	Fuse, Thermal Protector for Fan Motor	Fuse, Thermal Protector for Fan Motor
Refrigerant Control			Electronic Expansion Valve	Electronic Expansion Valve	Electronic Expansion Valve
Connectable Outdoor Unit			R410A M Series	R410A M Series	R410A M Series
Standard Accessories			Operation Manual, Installation Manual, Insulation for Fitting, Drain Hose, Clamps, Screws, Washers, Level Adjustment Screw.	Operation Manual, Installation Manual, Insulation for Fitting, Drain Hose, Clamps, Screws, Washers, Level Adjustment Screw.	Operation Manual, Installation Manual, Insulation for Fitting, Drain Hose, Clamps, Screws, Washers, Level Adjustment Screw.
Drawing No.			3D038817		

## Notes:

- H1 Indoor temp. : 27°CDB, 19.5°CWB / outdoor temp.: 35°CDB / Equivalent piping length: 7.5m, level difference: 0m.
- H2 Indoor temp. : 27°CDB, 19.0°CWB / outdoor temp.: 35°CDB / Equivalent piping length: 7.5m, level difference: 0m.
- H3 Indoor temp. : 20°CDB / outdoor temp.: 7°CDB, 6°CWB / Equivalent piping length: 7.5m, level difference: 0m. (Heat pump only)
- 4 Capacities are net, including a deduction for cooling (an addition for heating) for indoor fan motor heat.
- H5 Anechoic chamber conversion value, measured at a point 1.5 m in front of the unit at a height of 1.5 m. During actual operation, these values are normally somewhat higher as a result of ambient conditions.

## Conversion Formulae

kcal/h=kWx860  
Btu/h=kWx3414  
cfm=m<sup>3</sup>/minx35.3

## Ceiling Suspended Cassette Type

Model	Indoor Unit		FXUQ71MV1	FXUQ100MV1	FXUQ125MV1
	Connection	Unit	BEVQ71MVE	BEVQ140MVE	BEVQ145MVE
H1 Cooling Capacity (19.5°CWB)		kcal/h	7,100	10,000	12,500
		Btu/h	28,200	39,700	49,600
		kW	8.3	11.6	14.5
H2 Cooling Capacity (19.0°CWB)		kW	8.0	11.2	14.0
H3 Heating Capacity		kcal/h	7,700	10,800	13,800
		Btu/h	30,700	42,700	54,600
		kW	9.0	12.5	16.0
Casing Color			White (10Y9/0.5)	White (10Y9/0.5)	White (10Y9/0.5)
Dimensions: (HxWxD)		mm	165x895x895	230x895x895	230x895x895
Coil (Cross Fin Coil)	RowsxStagesxFin Pitch	mm	3x6x1.5	3x8x1.5	3x8x1.5
	Face Area	m <sup>2</sup>	0.265	0.353	0.353
Fan	Model		QTS48A10M	QTS50B15M	QTS50B15M
	Type		Turbo Fan	Turbo Fan	Turbo Fan
	Motor Output x Number of Units	W	45x1	90x1	90x1
	Air Flow Rate (H/L)	m <sup>3</sup> /min	19/14	29/21	32/23
		cfm	671/494	1,024/741	1,130/812
Drive		Direct Drive	Direct Drive	Direct Drive	
Temperature Control			Microprocessor Thermostat for Cooling and Heating	Microprocessor Thermostat for Cooling and Heating	Microprocessor Thermostat for Cooling and Heating
Sound Absorbing Thermal Insulation Material			Heat Resistant Foamed Polyethylene, Regular Foamed Polyethylene	Heat Resistant Foamed Polyethylene, Regular Foamed Polyethylene	Heat Resistant Foamed Polyethylene, Regular Foamed Polyethylene
Piping Connections	Liquid Pipes	mm	φ9.5 (Flare Connection)	φ9.5 (Flare Connection)	φ9.5 (Flare Connection)
	Gas Pipes	mm	φ15.9 (Flare Connection)	φ19.1 (Flare Connection)	φ19.1 (Flare Connection)
	Drain Pipe	mm	I.Dφ20xO.Dφ26	I.Dφ20xO.Dφ26	I.Dφ20xO.Dφ26
Machine Weight (Mass)		kg	25	31	31
H5 Sound Level (H/L)		dBA	40/35	43/38	44/39
Safety Devices			Thermal Protector for Fan Motor	Thermal Protector for Fan Motor	Thermal Protector for Fan Motor
Standard Accessories			Operation Manual, Installation Manual, Drain Hose, Clamp Metal, Insulation for Fitting, Sealing Pads, Clamps, Screws, Washers, Holding Plate.	Operation Manual, Installation Manual, Drain Hose, Clamp Metal, Insulation for Fitting, Sealing Pads, Clamps, Screws, Washers, Holding Plate.	Operation Manual, Installation Manual, Drain Hose, Clamp Metal, Insulation for Fitting, Sealing Pads, Clamps, Screws, Washers, Holding Plate.
Drawing No.			4D049395		

## Notes:

- H1 Indoor temp. : 27°CDB, 19.5°CWB / outdoor temp.: 35°CDB / Equivalent piping length: 7.5m, level difference: 0m.
- H2 Indoor temp. : 27°CDB, 19.0°CWB / outdoor temp.: 35°CDB / Equivalent piping length: 7.5m, level difference: 0m.
- H3 Indoor temp. : 20°CDB / outdoor temp.: 7°CDB, 6°CWB / Equivalent piping length; 7.5m, level difference; 0m. (Heat pump only)
- 4 Capacities are net, including a deduction for cooling (an additional for heating) for indoor fan motor heat.
- H5 Anechoic chamber conversion value, measured at a point 1.5m downward from the unit center. These values are normally somewhat higher during actual operation as a result of ambient conditions.

Conversion Formulae
kcal/h=kWx860
Btu/h=kWx3414
cfm=m <sup>3</sup> /minx35.3

## BEV Units

Model	BEVQ71MVE		BEVQ100MVE	BEVQ125MVE	
Power Supply	1 Phase 50Hz 220~240V		1 Phase 50Hz 220~240V	1 Phase 50Hz 220~240V	
Casing	Galvanized Steel Plate		Galvanized Steel Plate	Galvanized Steel Plate	
Dimensions: (HxWxD)	mm	100x350x225	100x350x225	100x350x225	
Sound Absorbing Thermal Insulation Material			Flame and Heat Resistant Foamed Polyethylene	Flame and Heat Resistant Foamed Polyethylene	
Piping Connection	Indoor Unit	Liquid Pipes	9.5mm (Flare Connection)	9.5mm (Flare Connection)	9.5mm (Flare Connection)
		Gas Pipes	15.9mm (Flare Connection)	15.9mm (Flare Connection)	15.9mm (Flare Connection)
	Outdoor Unit	Liquid Pipes	9.5mm (Flare Connection)	9.5mm (Flare Connection)	9.5mm (Flare Connection)
		Suction Gas Pipes	15.9mm (Flare Connection)	15.9mm (Flare Connection)	15.9mm (Flare Connection)
Machine Weight (Mass)		kg	3.0	3.0	3.5
Standard Accessories			Installation manual, Gas piping connections, Insulation for fitting, Sealing material, Clamps	Installation manual, Gas piping connections, Insulation for fitting, Sealing material, Clamps	Installation manual, Gas piping connections, Insulation for fitting, Sealing material, Clamps
Drawing No.			4D045387	4D045387	4D045388

## Wall Mounted Type

Model		FXAQ20MHV1	FXAQ25MHV1	FXAQ32MHV1	
H1 Cooling Capacity (19.5°CWB)	kcal/h	2,000	2,500	3,150	
	Btu/h	7,900	9,900	12,500	
	kW	2.3	2.9	3.7	
H2 Cooling Capacity (19.0°CWB)	kW	2.2	2.8	3.6	
H3 Heating Capacity	kcal/h	2,200	2,800	3,400	
	Btu/h	8,500	10,900	13,600	
	kW	2.5	3.2	4.0	
Casing Color		White (3.0Y8.5/0.5)	White (3.0Y8.5/0.5)	White (3.0Y8.5/0.5)	
Dimensions: (HxWxD)		mm	290x795x230	290x795x230	
Coil (Cross Fin Coil)	RowsxStagesxFin Pitch	mm	2x14x1.4	2x14x1.4	
	Face Area	m <sup>2</sup>	0.161	0.161	
Fan	Model		QCL9661M	QCL9661M	
	Type		Cross Flow Fan	Cross Flow Fan	
	Motor Output x Number of Units	W	40x1	40x1	
	Air Flow Rate (H/L)	m <sup>3</sup> /min	7.5/4.5	8/5	9/5.5
		cfm	265/159	282/177	318/194
Drive		Direct Drive	Direct Drive	Direct Drive	
Temperature Control		Microprocessor Thermostat for Cooling and Heating	Microprocessor Thermostat for Cooling and Heating	Microprocessor Thermostat for Cooling and Heating	
Sound Absorbing Thermal Insulation Material		Foamed Polystyrene / Foamed Polyethylene	Foamed Polystyrene / Foamed Polyethylene	Foamed Polystyrene / Foamed Polyethylene	
Air Filter		Resin Net (Washable)	Resin Net (Washable)	Resin Net (Washable)	
Piping Connections	Liquid Pipes	mm	φ6.4 (Flare Connection)	φ6.4 (Flare Connection)	
	Gas Pipes	mm	φ12.7 (Flare Connection)	φ12.7 (Flare Connection)	
	Drain Pipe	mm	VP13 (External Dia. 18 Internal Dia. 13)	VP13 (External Dia. 18 Internal Dia. 13)	
Machine Weight (Mass)		kg	11	11	
H5 Sound Level (H/L)		dBA	35/29	36/29	
Safety Devices		Fuse	Fuse	Fuse	
Refrigerant Control		—	—	—	
Connectable outdoor unit		R410A M Series	R410A M Series	R410A M Series	
Standard Accessories		Operation Manual, Installation Manual, Installation Panel, Paper Pattern for Installation, Insulation Tape, Clamps, screws.	Operation Manual, Installation Manual, Installation Panel, Paper Pattern for Installation, Insulation Tape, Clamps, screws.	Operation Manual, Installation Manual, Installation Panel, Paper Pattern for Installation, Insulation Tape, Clamps, screws.	
Drawing No.		3D046711			

## Notes:

- H1 Indoor temp. : 27°CDB, 19.5°CWB / outdoor temp.: 35°CDB / Equivalent piping length: 7.5m, level difference: 0m.
- H2 Indoor temp. : 27°CDB, 19.0°CWB / outdoor temp.: 35°CDB / Equivalent piping length: 7.5m, level difference: 0m.
- H3 Indoor temp. : 20°CDB / outdoor temp.: 7°CDB, 6°CWB / Equivalent piping length: 7.5m, level difference: 0m. (Heat pump only)
- 4 Capacities are net, including a deduction for cooling (an addition for heating) for indoor fan motor heat.
- H5 Anechoic chamber conversion value, measured under JISB8616 conditions. During actual operation, these values are normally somewhat higher as a result of ambient conditions.

## Conversion Formulae

$$\begin{aligned} \text{kcal/h} &= \text{kW} \times 860 \\ \text{Btu/h} &= \text{kW} \times 3414 \\ \text{cfm} &= \text{m}^3/\text{min} \times 35.3 \end{aligned}$$

## Wall Mounted Type

Model			FXAQ40MHV1	FXAQ50MHV1
H1 Cooling Capacity (19.5°CWB)	kcal/h		4,000	5,000
	Btu/h		15,900	19,900
	kW		4.7	5.8
H2 Cooling Capacity (19.0°CWB)	kW		4.5	5.6
H3 Heating Capacity	kcal/h		4,300	5,400
	Btu/h		17,000	21,500
	kW		5.0	6.3
Casing Color			White (3.0Y8.5/0.5)	White (3.0Y8.5/0.5)
Dimensions: (HxWxD)		mm	290x1,050x230	290x1,050x230
Coil (Cross Fin Coil)	RowsxStagesxFin Pitch	mm	2x14x1.4	2x14x1.4
	Face Area	m <sup>2</sup>	0.213	0.213
Fan	Model		QCL9686M	QCL9686M
	Type		Cross Flow Fan	Cross Flow Fan
	Motor Output x Number of Units	W	43x1	43x1
	Air Flow Rate (H/L)	m <sup>3</sup> /min	12/9	15/12
		cfm	424/318	530/424
Drive		Direct Drive	Direct Drive	
Temperature Control			Microprocessor Thermostat for Cooling and Heating	Microprocessor Thermostat for Cooling and Heating
Sound Absorbing Thermal Insulation Material			Foamed Polystyrene / Foamed Polyethylene	Foamed Polystyrene / Foamed Polyethylene
Air Filter			Resin Net (Washable)	Resin Net (Washable)
Piping Connections	Liquid Pipes	mm	φ6.4 (Flare Connection)	φ6.4 (Flare Connection)
	Gas Pipes	mm	φ12.7 (Flare Connection)	φ12.7 (Flare Connection)
	Drain Pipe	mm	VP13 (External Dia. 18 Internal Dia. 13)	VP13 (External Dia. 18 Internal Dia. 13)
Machine Weight (Mass)	kg	13	13	
H5 Sound Level (H/L)	dBA	39/34	42/36	
Safety Devices			Fuse	Fuse
Refrigerant Control			—	—
Connectable outdoor unit			R410A M Series	R410A M Series
Standard Accessories			Operation Manual, Installation Manual, Installation Panel, Paper Pattern for Installation, Insulation Tape, Clamps, screws.	Operation Manual, Installation Manual, Installation Panel, Paper Pattern for Installation, Insulation Tape, Clamps, screws.
Drawing No.			3D046711	

## Notes:

- H1 Indoor temp. : 27°CDB, 19.5°CWB / outdoor temp; 35°CDB / Equivalent piping length: 7.5m, level difference: 0m.
- H2 Indoor temp. : 27°CDB, 19.0°CWB / outdoor temp; 35°CDB / Equivalent piping length: 7.5m, level difference: 0m.
- H3 Indoor temp. : 20°CDB / outdoor temp.: 7°CDB, 6°CWB / Equivalent piping length; 7.5m, level difference; 0m. (Heat pump only)
- 4 Capacities are net, including a deduction for cooling (an addition for heating) for indoor fan motor heat.
- H5 Anechoic chamber conversion value, measured under JISB8616 conditions. During actual operation, these values are normally somewhat higher as a result of ambient conditions.

## Conversion Formulae

kcal/h=kWx860  
Btu/h=kWx3414  
cfm=m<sup>3</sup>/minx35.3

## BEV Units

Model			BEVQ50MVE
Power Supply			1 Phase 50Hz 220~240V
Casing			Galvanized Steel Plate
Dimensions: (HxWxD)		mm	100x350x225
Sound Absorbing Thermal Insulation Material			Flame and Heat Resistant Foamed Polyethylene
Piping Connection	Indoor Unit	Liquid Pipes	6.4mm (Flare Connection)
		Gas Pipes	12.7mm (Flare Connection)
	Outdoor Unit	Liquid Pipes	6.4mm (Flare Connection)
		Suction Gas Pipes	12.7mm (Flare Connection)
Machine Weight	kg	3.0	
Standard Accessories			Installation manual, Gas piping connections, Insulation for fitting, Sealing material, Clamps
Drawing No.			4D046708

## Floor Standing Type

Model			FXLQ20MHV1	FXLQ25MHV1	FXLQ32MHV1
H1 Cooling Capacity (19.5°CWB)		kcal/h	2,000	2,500	3,150
		Btu/h	7,900	9,900	12,500
		kW	2.3	2.9	3.7
H2 Cooling Capacity (19.0°CWB)		kW	2.2	2.8	3.6
H3 Heating Capacity		kcal/h	2,200	2,800	3,400
		Btu/h	8,500	10,900	13,600
		kW	2.5	3.2	4.0
Casing Color			Ivory White (5Y7.5/1)	Ivory White (5Y7.5/1)	Ivory White (5Y7.5/1)
Dimensions: (HxWxD)		mm	600x1,000x222	600x1,000x222	600x1,140x222
Coil (Cross Fin Coil)	RowsxStagesxFin Pitch	mm	3x14x1.5	3x14x1.5	3x14x1.5
	Face Area	m <sup>2</sup>	0.159	0.159	0.200
Fan	Model		D14B20	D14B20	2D14B13
	Type		Sirocco Fan	Sirocco Fan	Sirocco Fan
	Motor Output x Number of Units	W	15x1	15x1	25x1
	Air Flow Rate (H/L)	m <sup>3</sup> /min	7/6	7/6	8/6
		cfm	247/212	247/212	282/212
Drive			Direct Drive	Direct Drive	Direct Drive
Temperature Control			Microprocessor Thermostat for Cooling and Heating	Microprocessor Thermostat for Cooling and Heating	Microprocessor Thermostat for Cooling and Heating
Sound Absorbing Thermal Insulation Material			Glass Fiber/ Urethane Foam	Glass Fiber/ Urethane Foam	Glass Fiber/ Urethane Foam
Air Filter			Resin Net (with Mold Resistant)	Resin Net (with Mold Resistant)	Resin Net (with Mold Resistant)
Piping Connections	Liquid Pipes	mm	φ6.4 (Flare Connection)	φ6.4 (Flare Connection)	φ6.4 (Flare Connection)
	Gas Pipes	mm	φ12.7 (Flare Connection)	φ12.7 (Flare Connection)	φ12.7 (Flare Connection)
	Drain Pipe	mm	φ21 O.D (Vinyl Chloride)	φ21 O.D (Vinyl Chloride)	φ21 O.D (Vinyl Chloride)
Machine Weight (Mass)		kg	25	25	30
H5 Sound Level (H/L) (220V)		dBA	35/32	35/32	35/32
Safety Devices			Thermal Protector for Fan Motor	Thermal Protector for Fan Motor	Thermal Protector for Fan Motor
Refrigerant Control			—	—	—
Connectable Outdoor Unit			R410A M Series	R410A M Series	R410A M Series
Standard Accessories			Operation Manual, Installation Manual, Insulation for Fitting, Drain Hose, Clamps, Screws, Washers, Level Adjustment Screw.	Operation Manual, Installation Manual, Insulation for Fitting, Drain Hose, Clamps, Screws, Washers, Level Adjustment Screw.	Operation Manual, Installation Manual, Insulation for Fitting, Drain Hose, Clamps, Screws, Washers, Level Adjustment Screw.
Drawing No.			3D047065		

## Notes:

- H1 Indoor temp. : 27°CDB, 19.5°CWB / outdoor temp.: 35°CDB / Equivalent piping length: 7.5m, level difference: 0m.
- H2 Indoor temp. : 27°CDB, 19.0°CWB / outdoor temp.: 35°CDB / Equivalent piping length: 7.5m, level difference: 0m.
- H3 Indoor temp. : 20°CDB / outdoor temp.: 7°CDB, 6°CWB / Equivalent piping length; 7.5m, level difference; 0m. (Heat pump only)
- 4 Capacities are net, including a deduction for cooling (an addition for heating) for indoor fan motor heat.
- H5 Anechoic chamber conversion value, measured at a point 1.5 m in front of the unit at a height of 1.5 m. During actual operation, these values are normally somewhat higher as a result of ambient conditions.

## Conversion Formulae

kcal/h=kWx860  
Btu/h=kWx3414  
cfm=m<sup>3</sup>/minx35.3



Floor Standing Type

Model		FXLQ40MHV1		FXLQ50MHV1	
H1 Cooling Capacity (19.5°CWB)	kcal/h	4,000		5,000	
	Btu/h	15,900		19,900	
	kW	4.7		5.8	
H2 Cooling Capacity (19.0°CWB)	kW	4.5		5.6	
H3 Heating Capacity	kcal/h	4,300		5,400	
	Btu/h	17,000		21,500	
	kW	5.0		6.3	
Casing Color		Ivory White (5Y7.5/1)		Ivory White (5Y7.5/1)	
Dimensions: (HxWxD)		mm	600x1,140x222		600x1,420x222
Coil (Cross Fin Coil)	RowsxStagesxFin Pitch	mm	3x14x1.5		3x14x1.5
	Face Area	m <sup>2</sup>	0.200		0.282
Fan	Model		2D14B13		2D14B20
	Type		Sirocco Fan		Sirocco Fan
	Motor Output x Number of Units	W	25x1		35x1
	Air Flow Rate (H/L)	m <sup>3</sup> /min	11/8.5		14/11
		cfm	388/300		494/388
Drive		Direct Drive		Direct Drive	
Temperature Control		Microprocessor Thermostat for Cooling and Heating		Microprocessor Thermostat for Cooling and Heating	
Sound Absorbing Thermal Insulation Material		Glass Fiber/ Urethane Foam		Glass Fiber/ Urethane Foam	
Air Filter		Resin Net (with Mold Resistant)		Resin Net (with Mold Resistant)	
Piping Connections	Liquid Pipes	mm	φ6.4 (Flare Connection)		φ6.4 (Flare Connection)
	Gas Pipes	mm	φ12.7 (Flare Connection)		φ12.7 (Flare Connection)
	Drain Pipe	mm	φ21 O.D (Vinyl Chloride)		φ21 O.D (Vinyl Chloride)
Machine Weight (Mass)		kg	30		36
H5 Sound Level (H/L)		dBA	38/33		39/34
Safety Devices		Thermal Protector for Fan Motor		Thermal Protector for Fan Motor	
Refrigerant Control		—		—	
Connectable Outdoor Unit		R410A M Series		R410A M Series	
Standard Accessories		Operation Manual, Installation Manual, Insulation for Fitting, Drain Hose, Clamps, Screws, Washers, Level Adjustment Screw.		Operation Manual, Installation Manual, Insulation for Fitting, Drain Hose, Clamps, Screws, Washers, Level Adjustment Screw.	
Drawing No.		3D047065			

Notes:

- H1 Indoor temp. : 27°CDB, 19.5°CWB / outdoor temp.: 35°CDB / Equivalent piping length: 7.5m, level difference: 0m.
- H2 Indoor temp. : 27°CDB, 19.0°CWB / outdoor temp.: 35°CDB / Equivalent piping length: 7.5m, level difference: 0m.
- H3 Indoor temp. : 20°CDB / outdoor temp.: 7°CDB, 6°CWB / Equivalent piping length; 7.5m, level difference; 0m. (Heat pump only)
- 4 Capacities are net, including a deduction for cooling (an addition for heating) for indoor fan motor heat.
- H5 Anechoic chamber conversion value, measured at a point 1.5 m in front of the unit at a height of 1.5 m. During actual operation, these values are normally somewhat higher as a result of ambient conditions.

Conversion Formulae
kcal/h=kWx860
Btu/h=kWx3414
cfm=m <sup>3</sup> /minx35.3

## Outdoor Air Processing Unit

Model		FXMQ125MFV1	FXMQ200MFV1	FXMQ250MFV1	
H1 Cooling Capacity	kcal/h	12,000	19,300	24,100	
	Btu/h	47,800	76,500	95,600	
	kW	14.0	22.4	28.0	
H1 Heating Capacity	kcal/h	7,700	12,000	15,000	
	Btu/h	30,000	47,500	59,400	
	kW	8.9	13.9	17.4	
Casing		Galvanized Steel Plate	Galvanized Steel Plate	Galvanized Steel Plate	
Dimensions: (HxWxD)		mm	470x744x1,100	470x1,380x1,100	
Coil (Cross Fin Coil)	RowsxStagesxFin Pitch	mm	3x26x2.0	3x26x2.0	
	Face Area	m <sup>2</sup>	0.28	0.65	
Fan	Model		D13/4G2DA1	D13/4G2DA1	
	Type		Sirocco Fan	Sirocco Fan	
	Motor Output x Number of Units	W	380x1	380x1	
	Air Flow Rate (H/L)	m <sup>3</sup> /min	18	28	35
		cfm	635	988	1,236
	External Static Pressure H4	Pa	185	225	205
Drive		Direct Drive	Direct Drive	Direct Drive	
Temperature Control		Microprocessor Thermostat for Cooling and Heating	Microprocessor Thermostat for Cooling and Heating	Microprocessor Thermostat for Cooling and Heating	
Sound Absorbing Thermal Insulation Material		Glass Fiber	Glass Fiber	Glass Fiber	
Air Filter		H2	H2	H2	
Piping Connections	Liquid Pipes	9.5mm (Flare Connection)	9.5mm (Flare Connection)	9.5mm (Flare Connection)	
	Gas Pipes	15.9mm (Flare Connection)	19.1mm (Brazing Connection)	22.2mm (Brazing Connection)	
	Drain Pipe	(mm) PS1B (female thread)	PS1B (female thread)	PS1B (female thread)	
Machine Weight (Mass)	kg	86	123	123	
Sound Level (220V) H3,H4	dBA	42	47	47	
Safety Devices		Fuse Thermal Protector for Fan Motor	Fuse Thermal Protector for Fan Motor	Fuse Thermal Protector for Fan Motor	
Refrigerant Control		Electronic Expansion Valve	Electronic Expansion Valve	Electronic Expansion Valve	
Standard Accessories		Operation Manual, Installation Manual, Sealing Pads, Screws, Clamps.	Operation Manual, Installation Manual, Sealing Pads, Connection Pipes, Screws, Clamps.	Operation Manual, Installation Manual, Sealing Pads, Connection Pipes, Screws, Clamps.	
Connectable Outdoor Units H5,H6		RXYQ8-48MY1B	RXYQ8-48MY1B	RXYQ10-48MY1B	
Drawing No.		3D046147A	3D046147A	3D046147A	

**Notes:**

H1. Specifications are based on the following conditions:

- Cooling: Outdoor temp. of 33°CDB, 28°CWB (68% RH). and discharge temp. of 18°CDB
- Heating: Outdoor temp. of 0°CDB, -2.9°CWB (50% RH). and discharge temp. of 25°CDB
- Equivalent reference piping length: 7.5m (0m Horizontal)
- At 220V

H2. Air intake filter is not supplied, so be sure to install the optional long-life filter or high-efficiency filter. Please mount it in the duct system of the suction side. Select its colorimetric method (gravity method) 50% or more.

H3. Anechoic chamber conversion value, measured at a point 1.5m downward from the unit center. These values (measured at 220V) are normally somewhat higher during actual operation as a result of ambient conditions.

H4. Valves measured at 220 V.

H5. Within the range that the total capacity of indoor units is 50 to 100%, it is possible to connect to the outdoor unit.

H6. It is not possible to connect to the 5 HP outdoor unit. Not available for Heat Recovery type and VRV II-S series.

- This equipment cannot be incorporated into the refrigerant piping system or remote group control of the VRV II system.

## Conversion Formulae

kcal/h=kWx860  
Btu/h=kWx3414  
cfm=m<sup>3</sup>/minx35.3



# Part 3

## Refrigerant Circuit

1. Refrigerant Circuit .....	50
1.1 RXYQ5M (※ Products after January, 2004).....	50
1.2 RXYQ8, 10, 12M (※ Products after January, 2004).....	52
1.3 RXYQ14, 16M (※ Products after January, 2004) .....	54
1.4 Outdoor air processing unit FXMQ125~250MFV1 .....	56
2. Functional Parts Layout .....	57
2.1 RXYQ5M .....	57
2.2 RXYQ8, 10, 12M .....	58
2.3 RXYQ14, 16M .....	59
3. Refrigerant Flow for Each Operation Mode.....	60

# 1. Refrigerant Circuit

## 1.1 RXYQ5M (※ Products after January, 2004)

No. in refrigerant system diagram	Symbol	Name	Major Function
A	M1C	Inverter compressor (INV)	Inverter compressor is operated on frequencies between 52 Hz and 210 Hz by using the inverter. The number of operating steps is as follows when Inverter compressor is operated. RXYQ5M : 20 steps
D	M1F	Inverter fan	Since the system is of air heat exchanging type, the fan is operated at 8-step rotation speed by using the inverter.
E	Y1E	Electronic expansion valve (Main: EV1)	While in heating operation, PI control is applied to keep the outlet superheated degree of air heat exchanger constant.
G	Y1S	Solenoid valve (Hot gas: SVP)	Used to prevent the low pressure from transient falling.
J	Y2S	Solenoid valve (Receiver gas discharging: SVG)	Used to collect refrigerant to receiver.
K	Y4S	Solenoid valve (Injection)	Used to cool the compressor by injecting refrigerant when the compressor discharge temperature is high.
M	Y3S	4-way valve	Used to switch the operation mode between cooling and heating.
N	S1NPH	High pressure sensor	Used to detect high pressure.
O	S1NPL	Low pressure sensor	Used to detect low pressure.
P	S1PH	HP pressure switch (For INV compressor)	In order to prevent the increase of high pressure when a malfunction occurs, this switch is activated at high pressure of 3.8 MPA or more to stop the compressor operation.
S	—	Fusible plug	In order to prevent the increase of pressure when abnormal heating is caused by fire or others, the fusible part of the plug is molten at a temperature of 70 to 75°C to release the pressure into the atmosphere.
T	—	Pressure regulating valve 1 (Receiver to discharge pipe)	This valve opens at a pressure of 2 to 2.7 MPa for prevention of pressure increase, thus resulting in no damage of functional parts due to the increase of pressure in transportation or storage.
1	R1T	Thermistor (Outdoor air: Ta)	Used to detect outdoor temperature, correct discharge pipe temperature, and others.
2	R2T	Thermistor (Suction pipe: Ts)	Used to detect suction pipe temperature, keep the suction superheated degree constant in heating operation, and others.
3	R3T	Thermistor (INV discharge pipe: Tdi)	Used to detect discharge pipe temperature, make the temperature protection control of compressor, and others.
4	R4T	Thermistor (Heat exchanger deicer: Tb)	Used to detect liquid pipe temperature of air heat exchanger, determine defrosting operation, and others.
5	R5T	Thermistor (Sub-cooling heat-exchanger outlet)	Used to judge the refrigerant overcharge at the check operation.

**Note:** Please refer the refrigerant circuit for products before December, 2003 to service manual Si39-302.

RXYQ5M

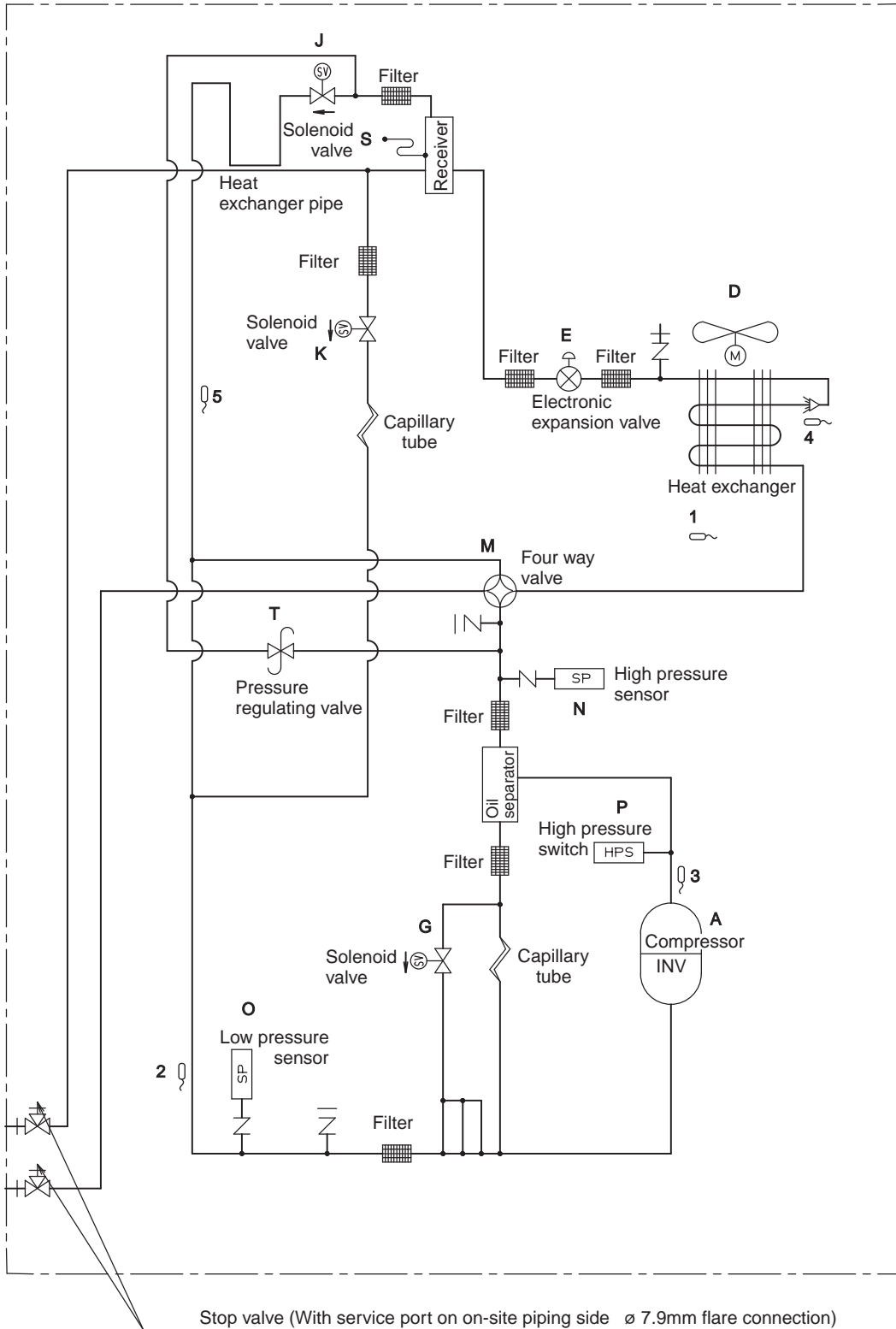

4D040337C

## 1.2 RXYQ8, 10, 12M (※ Products after January, 2004)

No. in refrigerant system diagram	Symbol	Name	Major Function
A	M1C	Inverter compressor (INV)	Inverter compressor is operated on frequencies between 52 Hz and 210 Hz by using the inverter, while Standard compressor is operated with commercial power supply only. The number of operating steps is as follows when Inverter compressor is operated in combination with Standard compressor. RXYQ8, 10, 12M: 29 steps
B	M2C	Standard compressor 1 (STD1)	
D	M1F	Inverter fan	Since the system is of air heat exchanging type, the fan is operated at 8-step rotation speed by using the inverter.
E	Y1E	Electronic expansion valve (Main: EV1)	While in heating operation, PI control is applied to keep the outlet superheated degree of air heat exchanger constant.
F	Y2E	Electronic expansion valve (Subcool: EV2)	PI control is applied to keep the outlet superheated degree of subcooling heat exchanger constant.
G	Y1S	Solenoid valve (Hot gas: SVP)	Used to prevent the low pressure from transient falling.
H	Y2S	Solenoid valve (Oil equalization: SVO)	Used for oil equalizing among outdoor units in multiple-outdoor-unit system.
J	Y3S	Solenoid valve (Receiver gas discharging: SVG)	Used to collect refrigerant to receiver.
L	Y4S	Solenoid valve (Non-operating unit liquid pipe closing: SVSL)	Used to prevent the accumulation of refrigerant in non-operating outdoor units in the case of multi-outdoor unit system.
M	Y5S	4-way valve	Used to switch the operation mode between cooling and heating.
N	S1NPH	High pressure sensor	Used to detect high pressure.
O	S1NPL	Low pressure sensor	Used to detect low pressure.
P	S1PH	HP pressure switch (For INV compressor)	In order to prevent the increase of high pressure when a malfunction occurs, this switch is activated at high pressure of 3.8 MPA or more to stop the compressor operation.
Q	S2PH	HP pressure switch (For STD compressor 2)	
S	—	Fusible plug	In order to prevent the increase of pressure when abnormal heating is caused by fire or others, the fusible part of the plug is molten at a temperature of 70 to 75°C to release the pressure into the atmosphere.
U	—	Pressure regulating valve 2 (Liquid pipe to receiver)	This valve opens at a pressure of 2 to 2.7 MPa for prevention of pressure increase, thus resulting in no damage of functional parts due to the increase of pressure in transportation or storage.
V	—	Pressure regulating valve 3 (Equalizing pipe to discharge pipe)	
1	R1T	Thermistor (Outdoor air: Ta)	Used to detect outdoor temperature, correct discharge pipe temperature, and others.
2	R2T	Thermistor (Suction pipe: Ts)	used to detect suction pipe temperature, keep the suction superheated degree constant in heating operation, and others.
3	R31T	Thermistor (INV discharge pipe: Tdi)	used to detect discharge pipe temperature, make the temperature protection control of compressor, and others.
4	R32T	Thermistor (STD1 discharge pipe: Tds1)	
6	R4T	Thermistor (Heat exchanger deicer: Tb)	Used to detect liquid pipe temperature of air heat exchanger, determine defrosting operation, and others.
7	R5T	Thermistor (Subcooling heat exchanger gas pipe: Tsh)	Used to detect gas pipe temperature on the evaporation side of subcooling heat exchanger, keep the superheated degree at the outlet of subcooling heat exchanger constant, and others.
8	R6T	Thermistor (Receiver outlet liquid pipe: TI)	Used to detect receiver outlet liquid pipe temperature, prevent the drift between outdoor units while in heating operation in the case of multiple-outdoor-unit system, and others.
9	R7T	Thermistor (Oil equalizing pipe: To)	Used to detect equalizing pipe temperature, opening/closing of the equalizing pipe stop valve, and others.

**Note:** Please refer the refrigerant circuit for products before December, 2003 to service manual Si39-302.

RXYQ8, 10, 12M

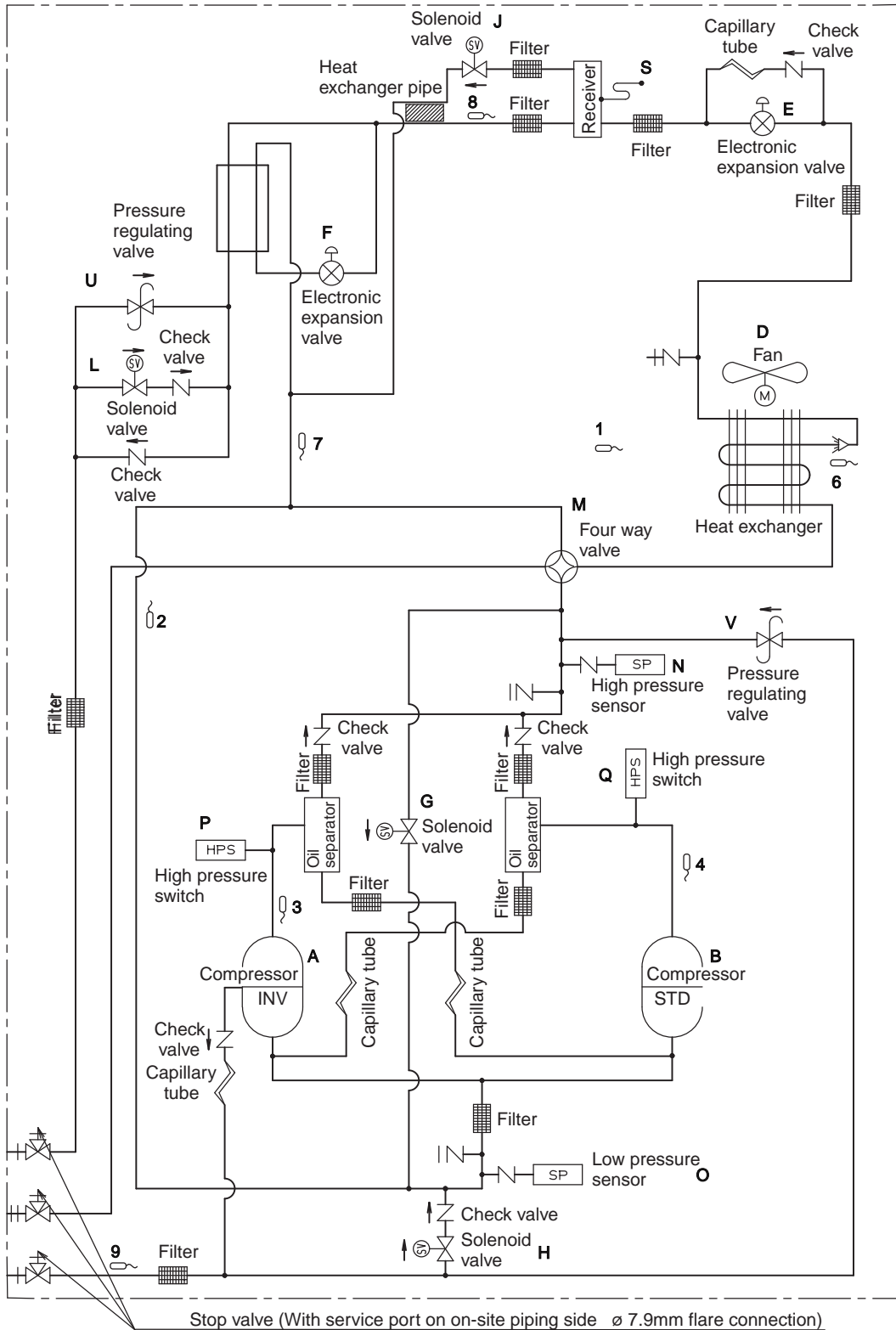

4D044808



### 1.3 RXYQ14, 16M (\*Products after January, 2004)

No. in refrigerant system diagram	Symbol	Name	Major Function
A	M1C	Inverter compressor (INV)	Inverter compressor is operated on frequencies between 52 Hz and 210 Hz by using the inverter, while Standard compressor is operated with commercial power supply only. The number of operating steps is as follows when Inverter compressor is operated in combination with Standard compressor. RXYQ14, 16M: 35 steps
B	M2C	Standard compressor 1 (STD1)	
C	M3C	Standard compressor 1 (STD2)	
D	M1F	Inverter fan	Since the system is of air heat exchanging type, the fan is operated at 8-step rotation speed by using the inverter.
E	Y1E	Electronic expansion valve (Main: EV1)	While in heating operation, PI control is applied to keep the outlet superheated degree of air heat exchanger constant.
F	Y2E	Electronic expansion valve (Subcool: EV2)	PI control is applied to keep the outlet superheated degree of subcooling heat exchanger constant.
G	Y1S	Solenoid valve (Hot gas: SVP)	Used to prevent the low pressure from transient falling.
H	Y2S	Solenoid valve (Oil equalization: SVO)	Used for oil equalizing among outdoor units in multiple-outdoor-unit system.
J	Y3S	Solenoid valve (Receiver gas discharging: SVG)	Used to collect refrigerant to receiver.
L	Y4S	Solenoid valve (Non-operating unit liquid pipe closing: SVSL)	Used to prevent the accumulation of refrigerant in non-operating outdoor units in the case of multi-outdoor unit system.
M	Y5S	4-way valve	Used to switch the operation mode between cooling and heating.
N	S1NPH	High pressure sensor	Used to detect high pressure.
O	S1NPL	Low pressure sensor	Used to detect low pressure.
P	S1PH	HP pressure switch (For INV compressor)	In order to prevent the increase of high pressure when a malfunction occurs, this switch is activated at high pressure of 3.8 MPA or more to stop the compressor operation.
Q	S2PH	HP pressure switch (For STD compressor 2)	
R	S3PH	HP pressure switch (For STD compressor 1)	
S	—	Fusible plug	In order to prevent the increase of pressure when abnormal heating is caused by fire or others, the fusible part of the plug is molten at a temperature of 70 to 75°C to release the pressure into the atmosphere.
U	—	Pressure regulating valve 2 (Liquid pipe to receiver)	This valve opens at a pressure of 2 to 2.7 MPA for prevention of pressure increase, thus resulting in no damage of functional parts due to the increase of pressure in transportation or storage.
V	—	Pressure regulating valve 3 (Equalizing pipe to discharge pipe)	
1	R1T	Thermistor (Outdoor air: Ta)	Used to detect outdoor temperature, correct discharge pipe temperature, and others.
2	R2T	Thermistor (Suction pipe: Ts)	used to detect suction pipe temperature, keep the suction superheated degree constant in heating operation, and others.
3	R31T	Thermistor (INV discharge pipe: Tdi)	used to detect discharge pipe temperature, make the temperature protection control of compressor, and others.
4	R32T	Thermistor (STD1 discharge pipe: Tds1)	
5	R33T	Thermistor (STD2 discharge pipe: Tds2)	
6	R4T	Thermistor (Heat exchanger deicer: Tb)	Used to detect liquid pipe temperature of air heat exchanger, determine defrosting operation, and others.
7	R5T	Thermistor (Subcooling heat exchanger gas pipe: Tsh)	Used to detect gas pipe temperature on the evaporation side of subcooling heat exchanger, keep the superheated degree at the outlet of subcooling heat exchanger constant, and others.
8	R6T	Thermistor (Receiver outlet liquid pipe: TI)	Used to detect receiver outlet liquid pipe temperature, prevent the drift between outdoor units while in heating operation in the case of multiple-outdoor-unit system, and others.
9	R7T	Thermistor (Oil equalizing pipe: To)	Used to detect equalizing pipe temperature, opening/closing of the equalizing pipe stop valve, and others.

**Note:** Please refer the refrigerant circuit for products before December, 2003 to service manual Si39-302.

RXYQ14, 16M

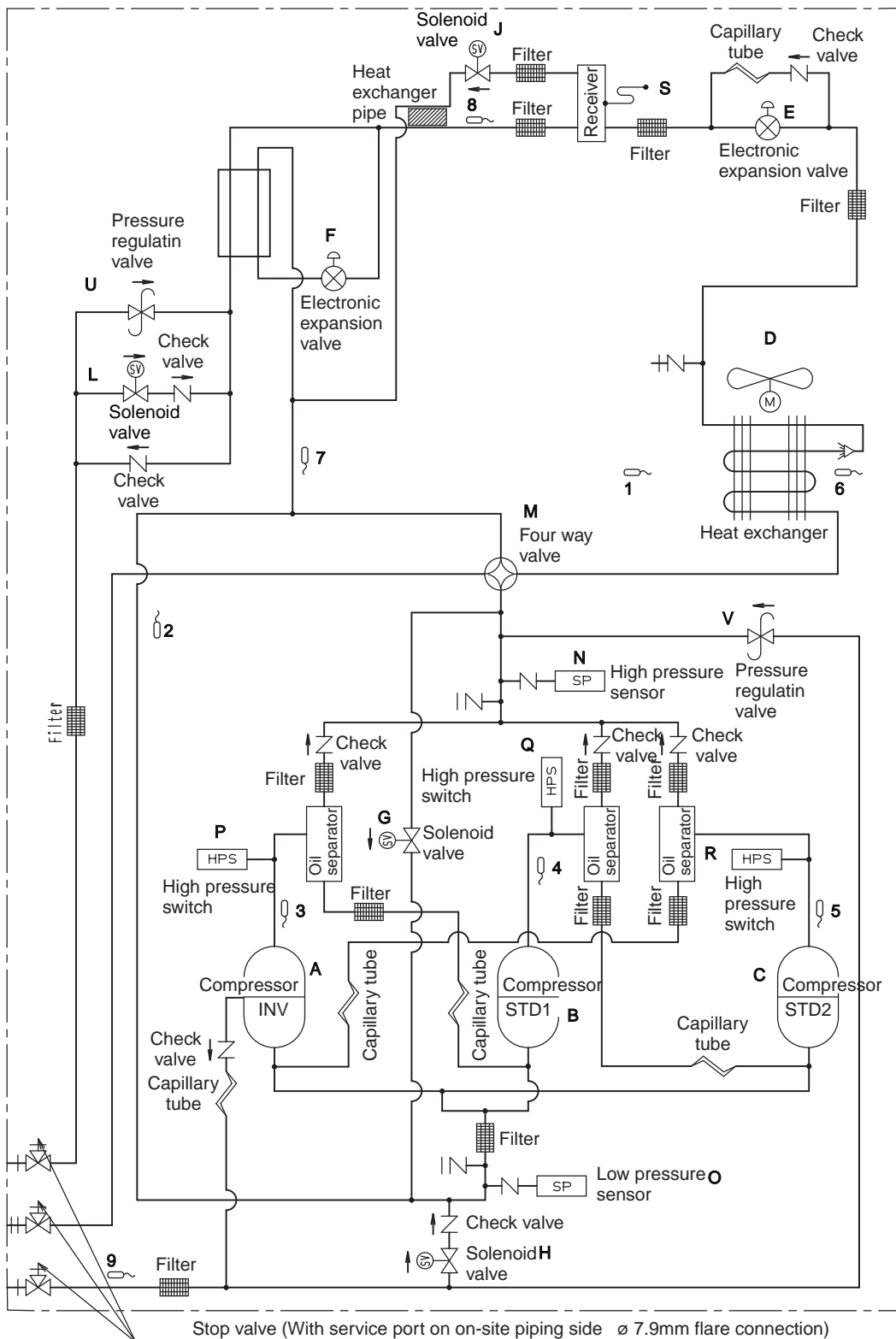

4D044809

## 1.4 Outdoor air processing unit FXMQ125~250MFV1

### 1.4.1 Refrigerant System

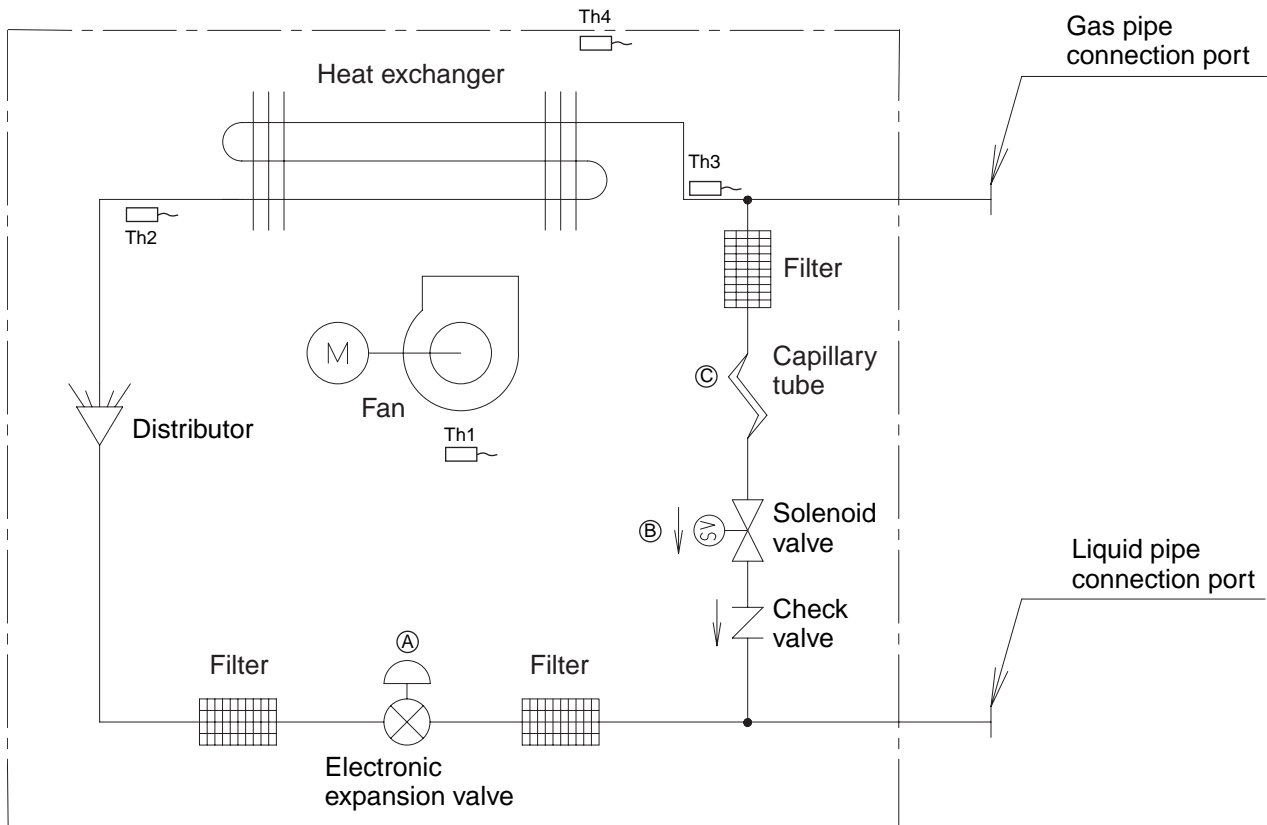

4D018650B

#### Main Control Equipment

Code	Symbol	Name	Main function
A	Y1E	Motorized valve	Used to control the flow rate of refrigerant, and make the SH control while in cooling or the SC control while in heating.*
B	Y1S	Solenoid valve	Used to bypass hot gas while in heating with thermostat OFF.
C	—	Capillary tube	Used to reduce pressure from high to low in bypassing hot gas.

\*SH control: Superheated control of heat exchanger outlet

SC control: Subcooled control of heat exchanger outlet

#### Thermistor

Code	Symbol	Name	Main function
Th1	R1T	Suction air temperature thermistor	Used to turn ON or OFF the thermostat and select cooling or heating operation.
Th2	R2T	Liquid pipe temperature thermistor	Used to control the opening degree of EV (Y1F) under the SC control.
Th3	R3T	Gas pipe temperature thermistor	Used to control the opening degree of EV (Y1E) under the SH control.
Th4	R4T	Discharge air temperature thermistor	Used to control the electric expansion valve opening and thermostat ON/OFF so as to keep the discharge air temperature at the set temperature.

## 2. Functional Parts Layout

### 2.1 RXYQ5M

#### Plan

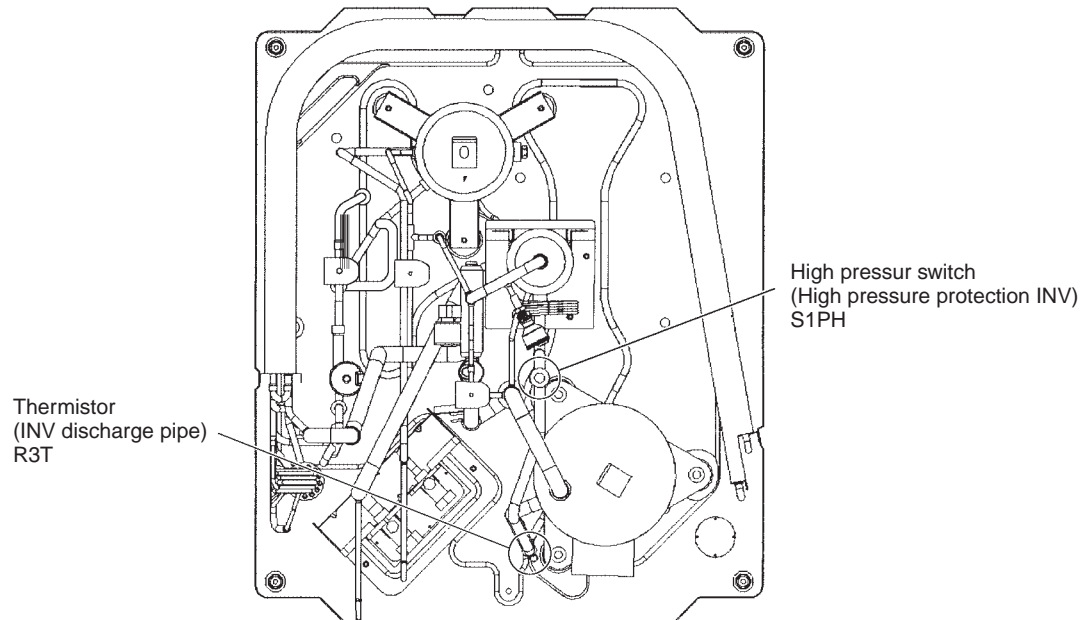

#### Front View

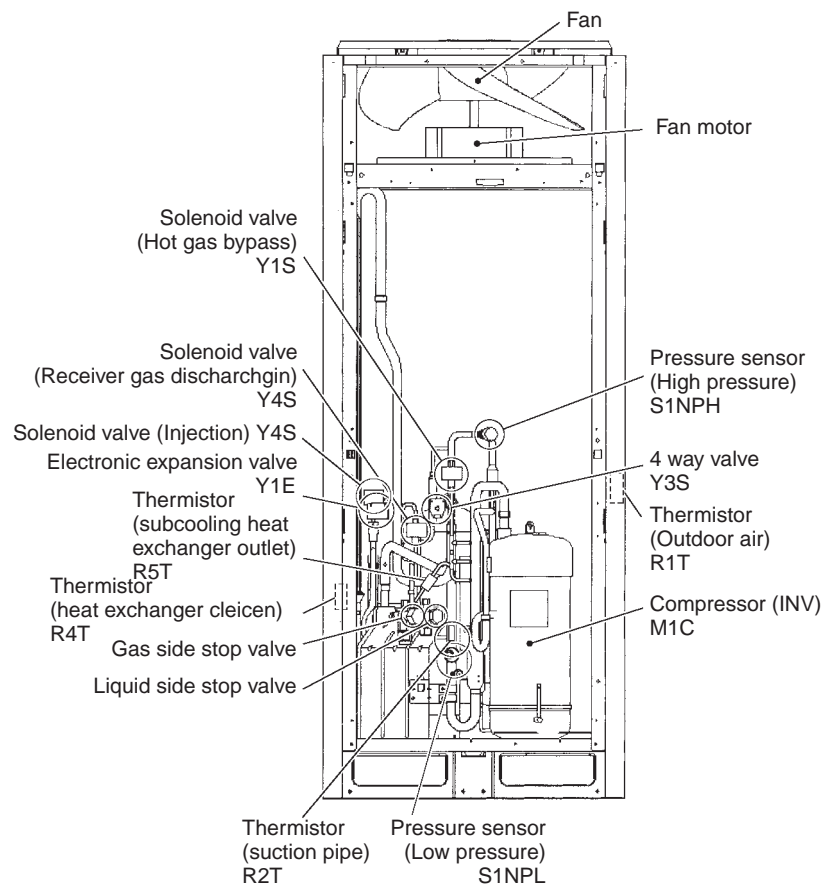

## 2.2 RXYQ8, 10, 12M

### Plan

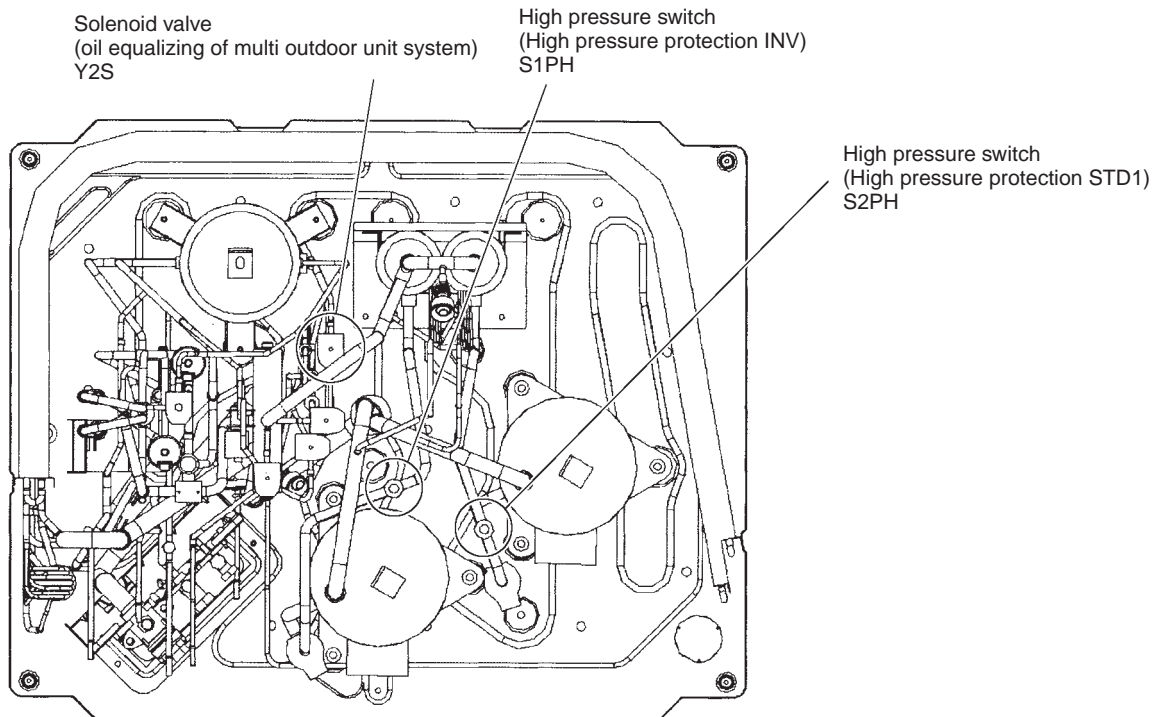

### Front View

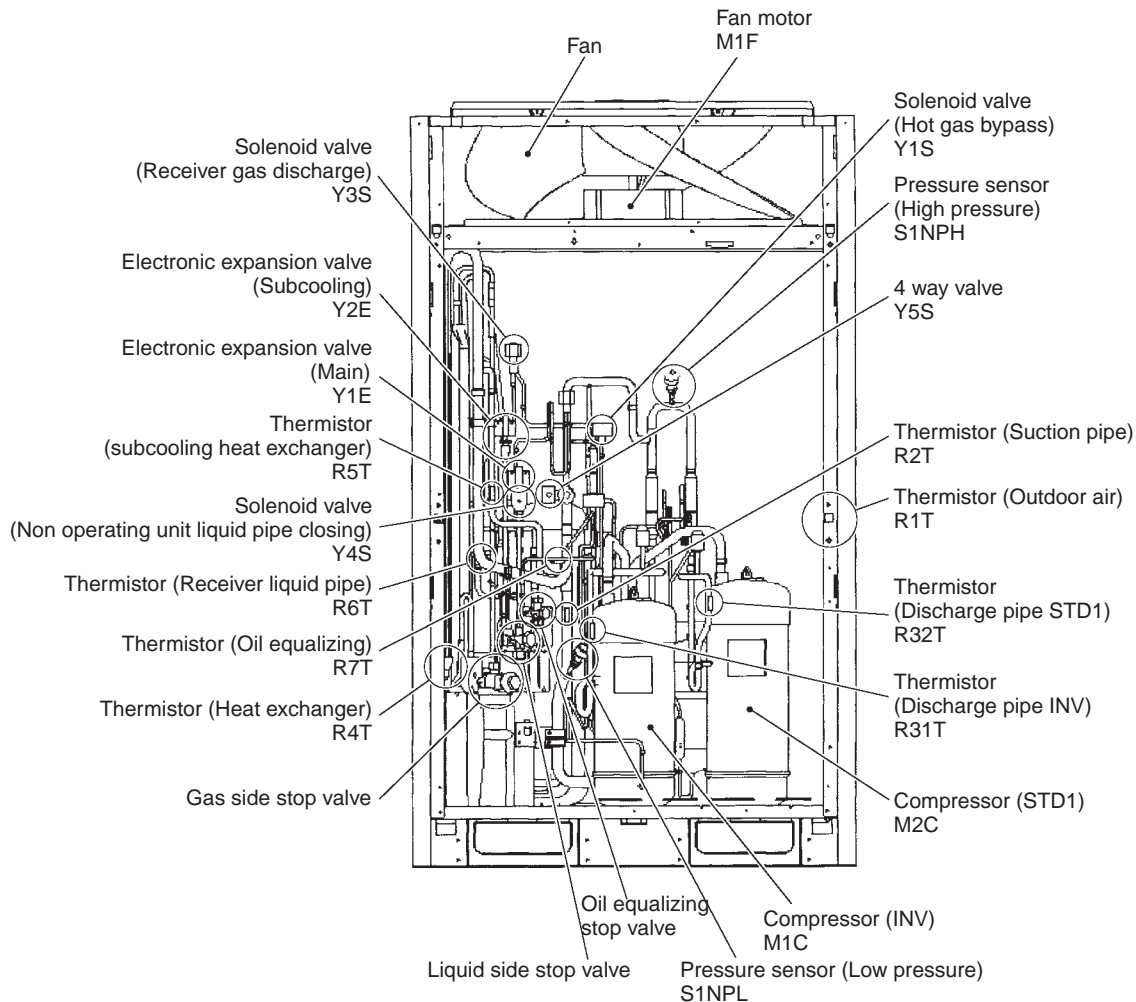

## 2.3 RXYQ14, 16M

### Plan

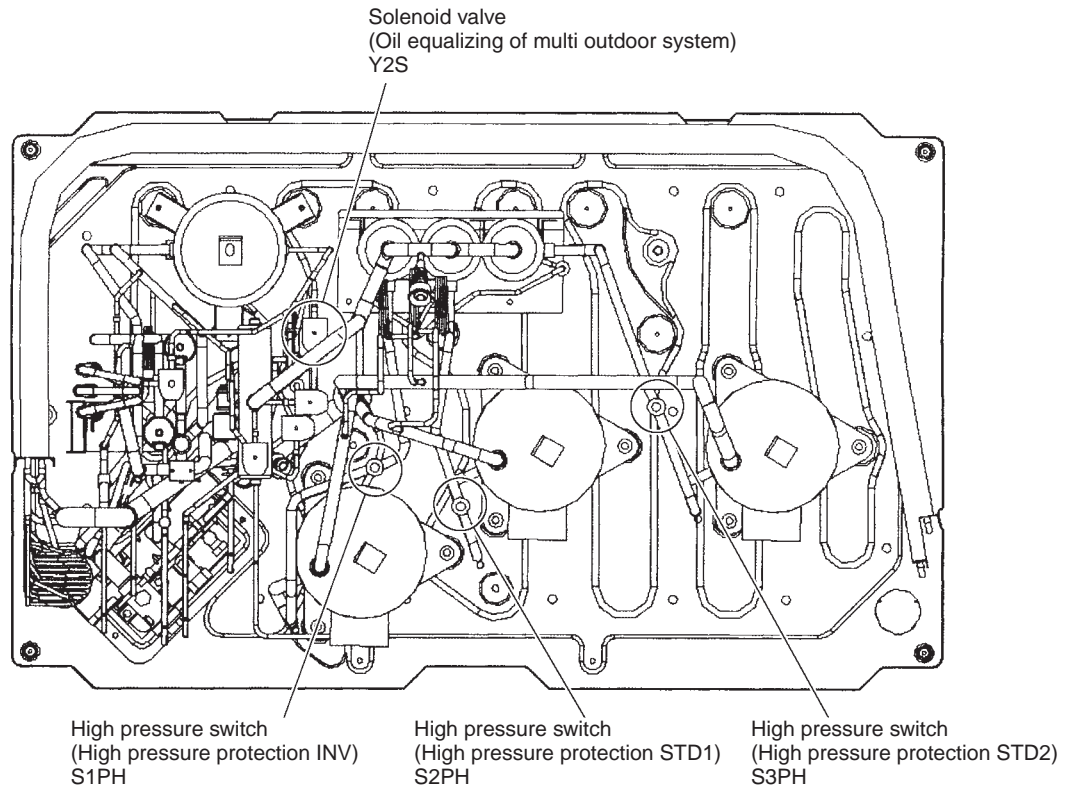

### Front View

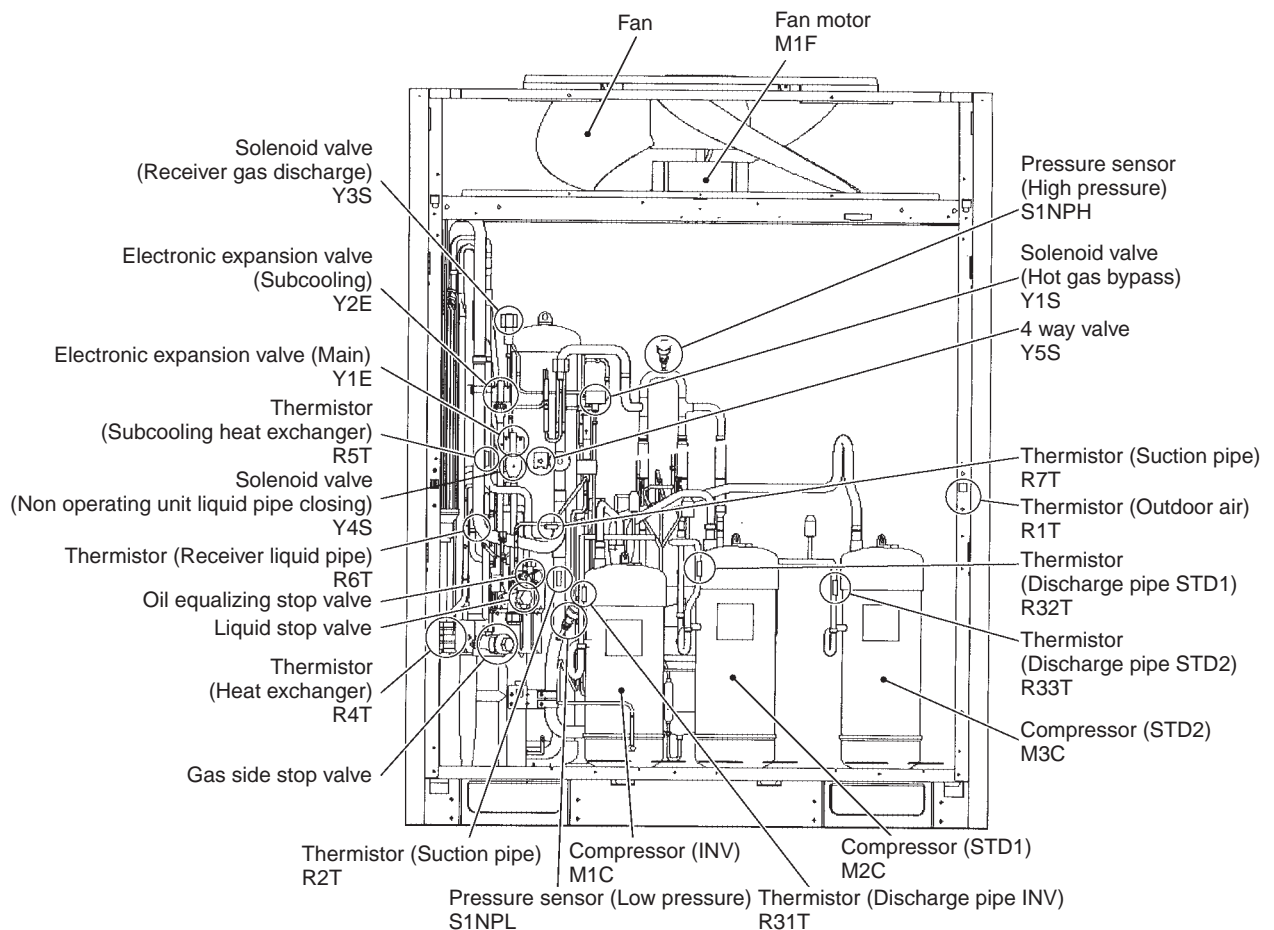

# 3. Refrigerant Flow for Each Operation Mode

RXYQ5M

Cooling Operation

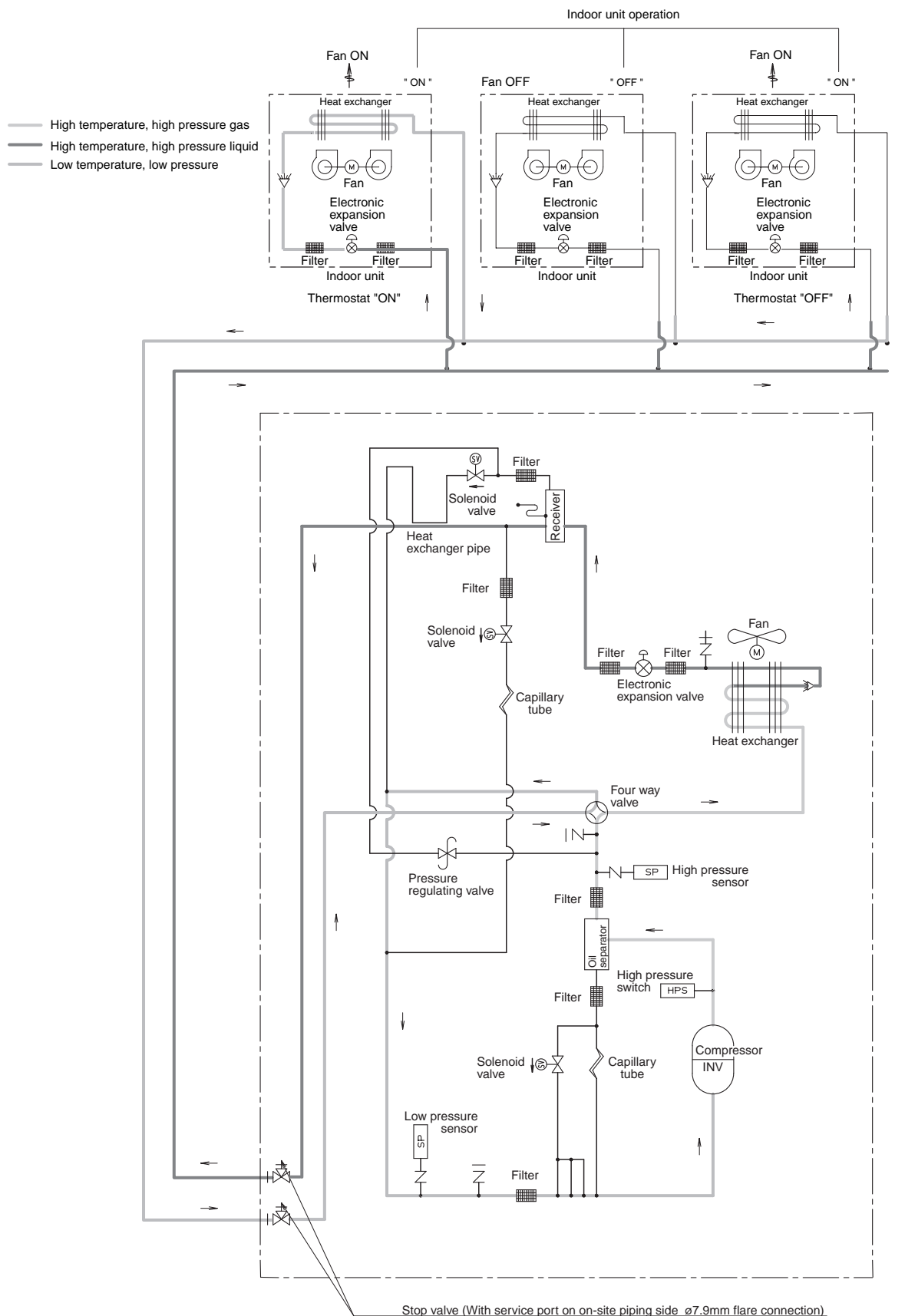

Cooling Oil Return Operation

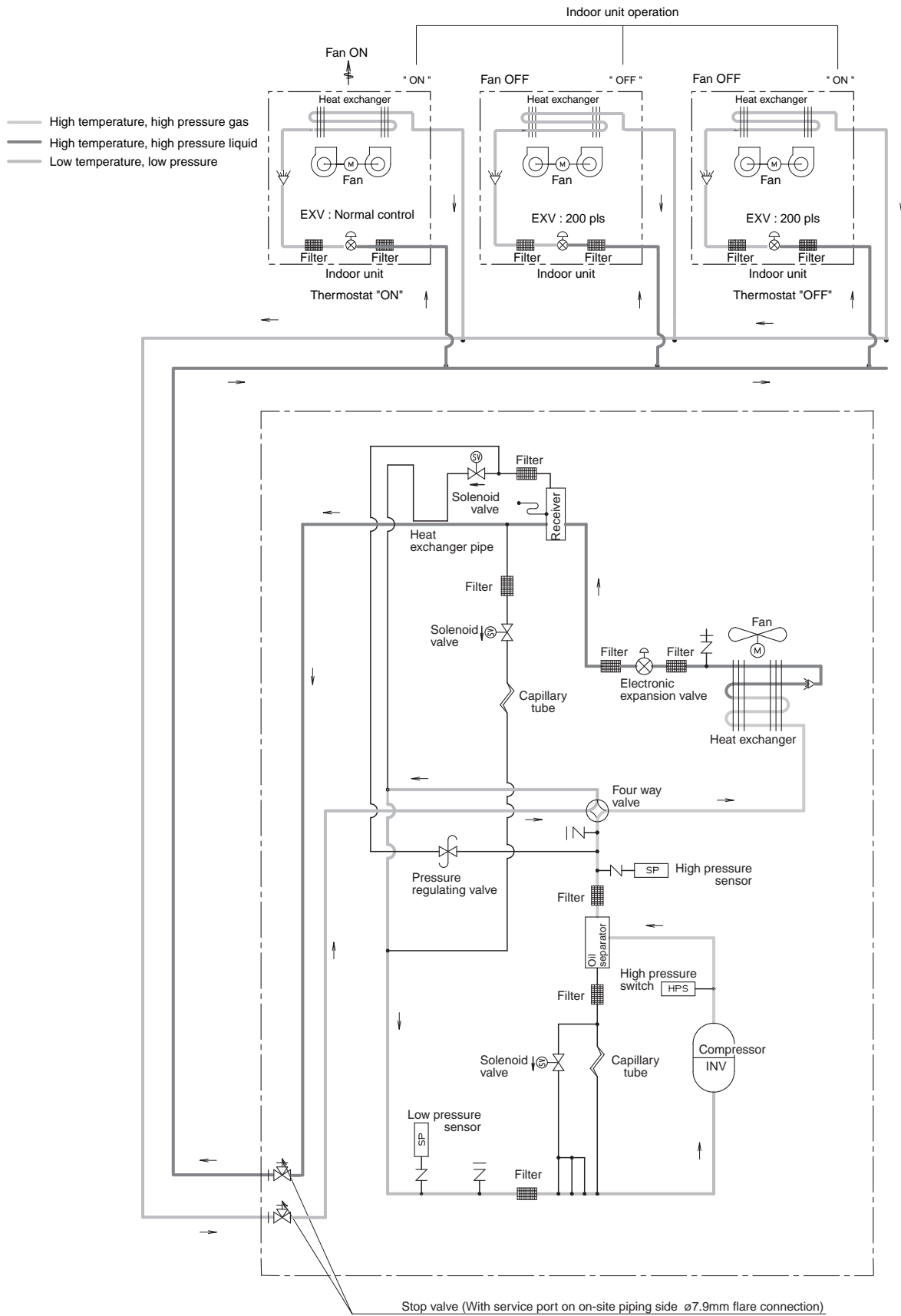

4D040337C



Heating Oil Return & Defrost Operation

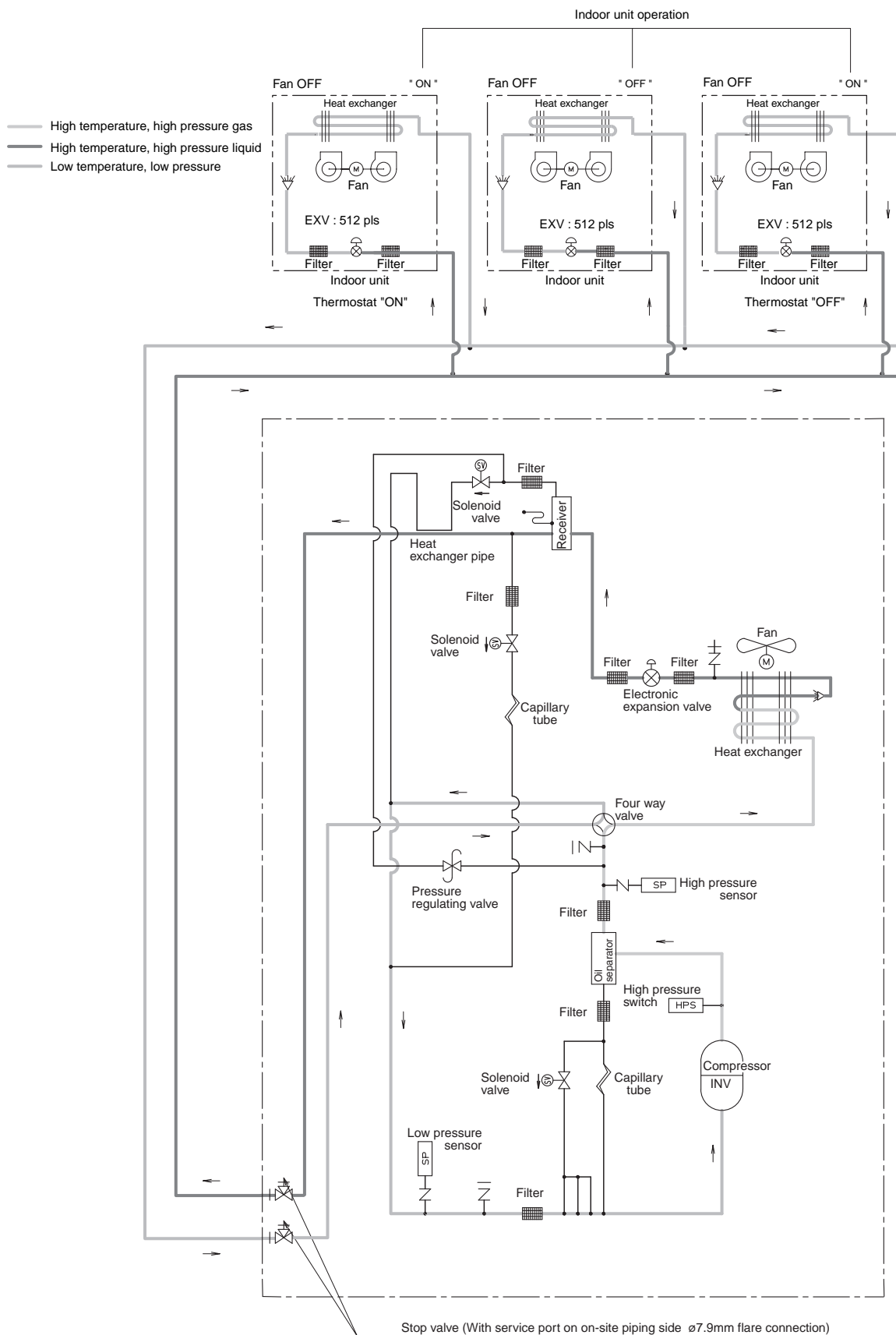

4D040337C

Heating Operation

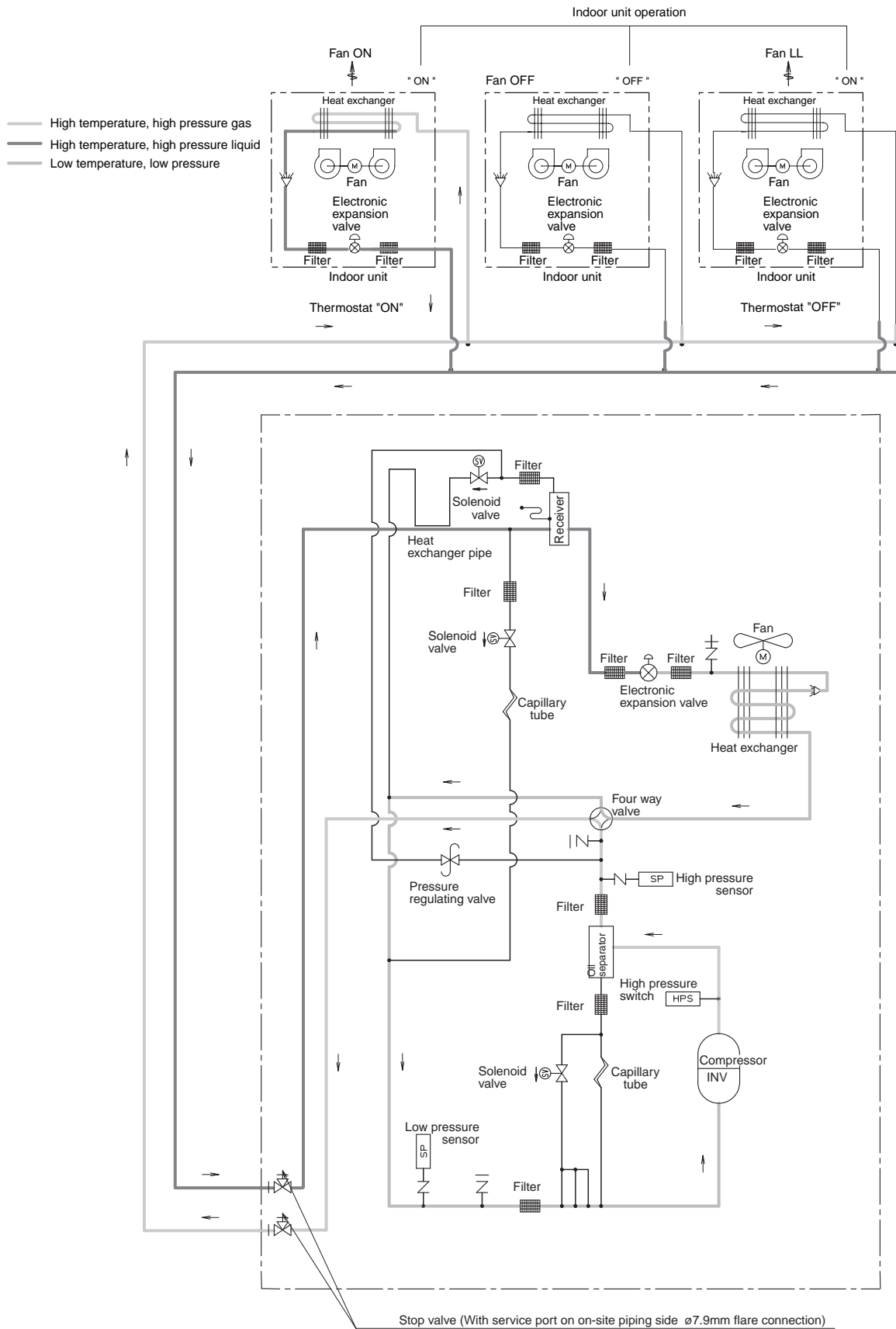

4D040337C

RXYQ8, 10, 12M  
Cooling Operation

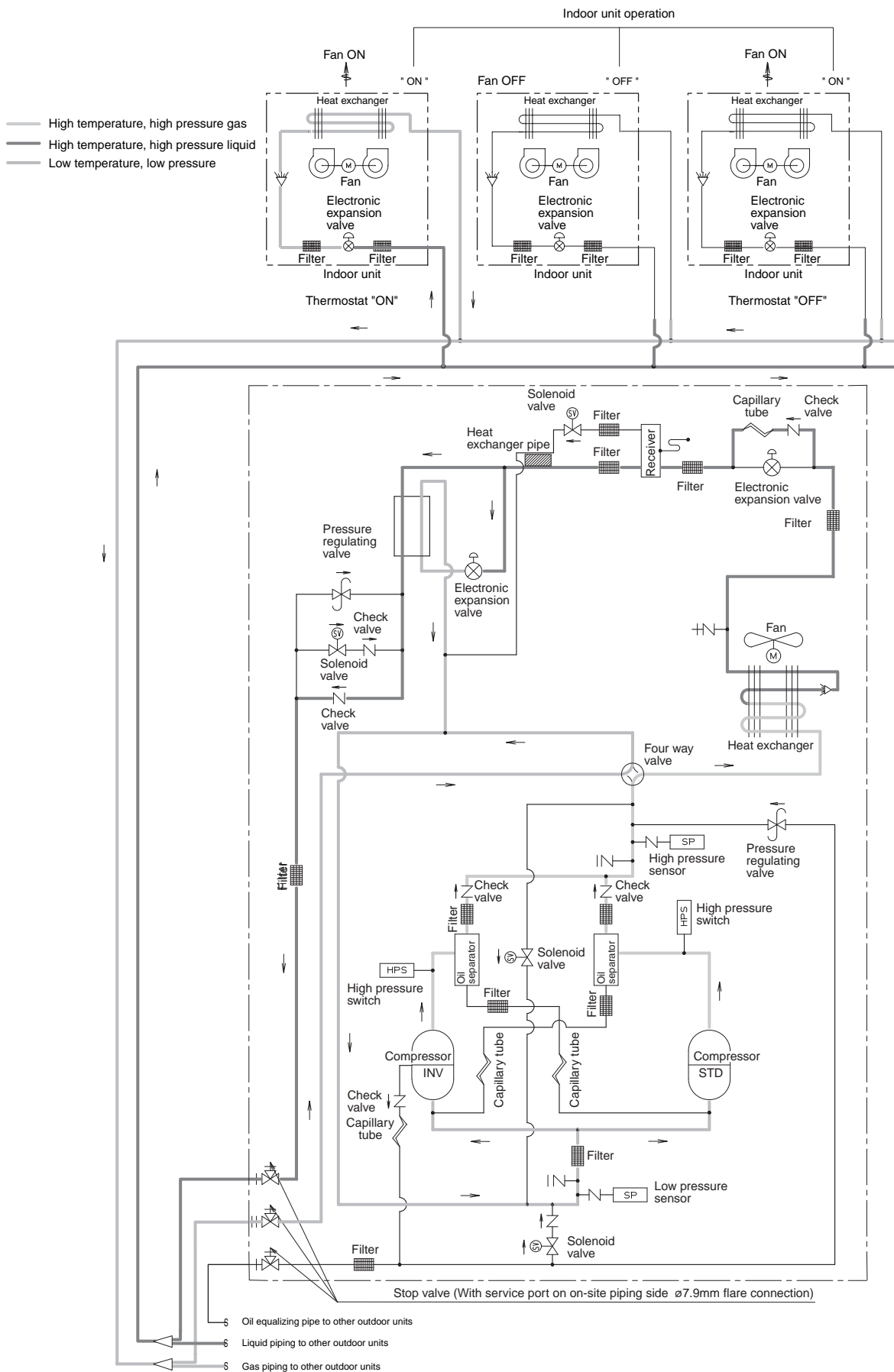

4D044808

Cooling Oil Return

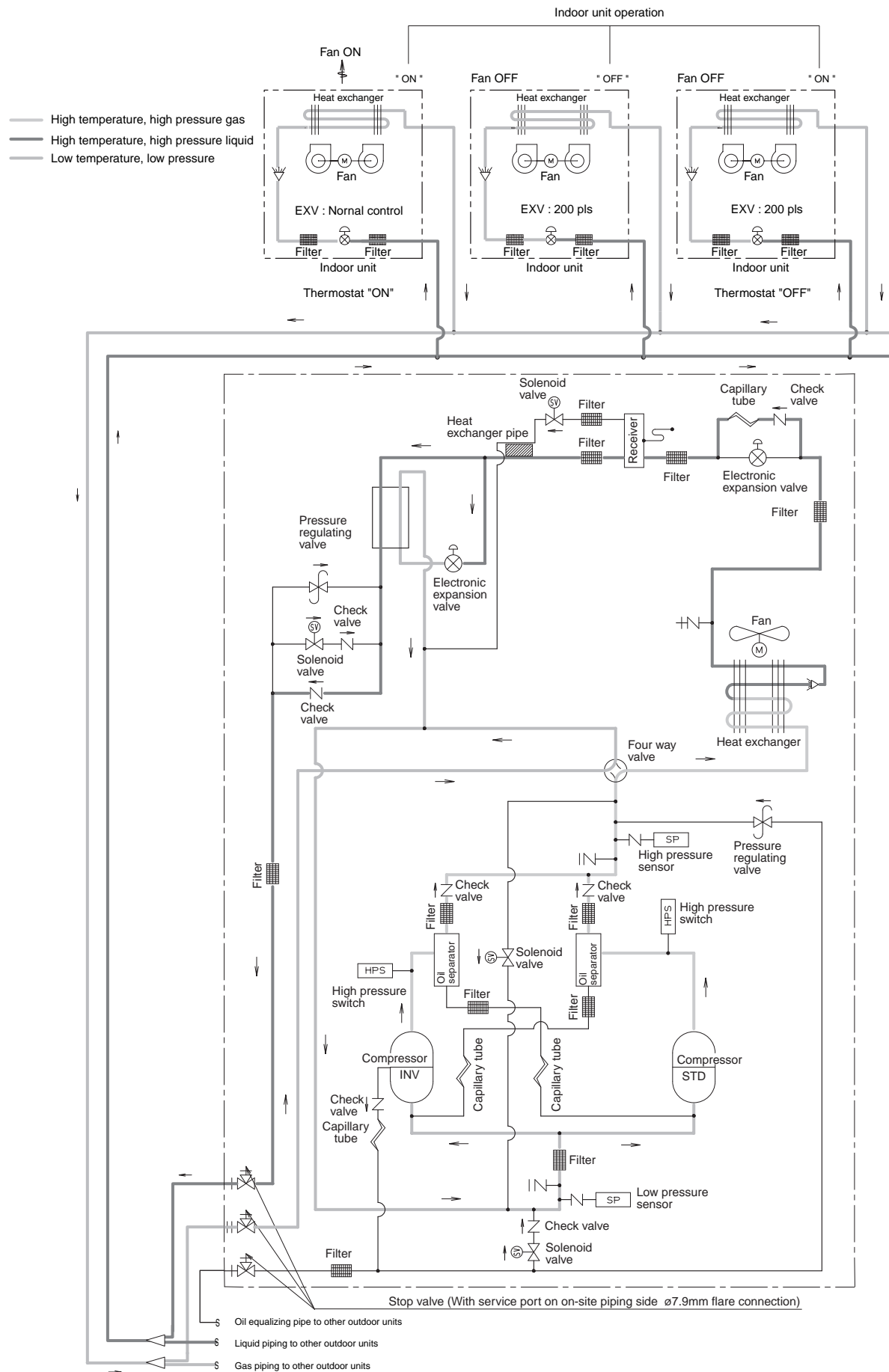

Heating Oil Return & Defrost

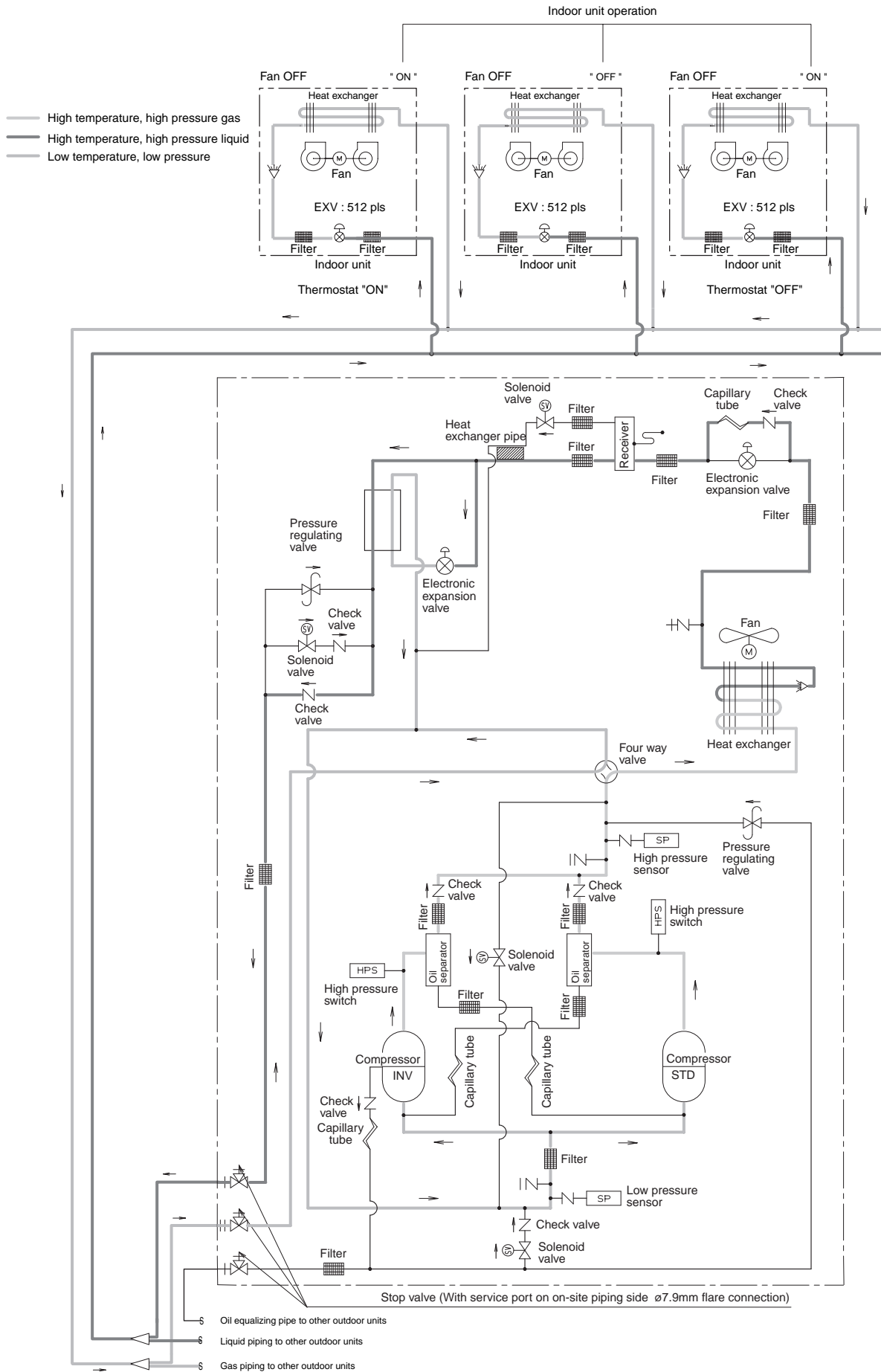

Heating Operation

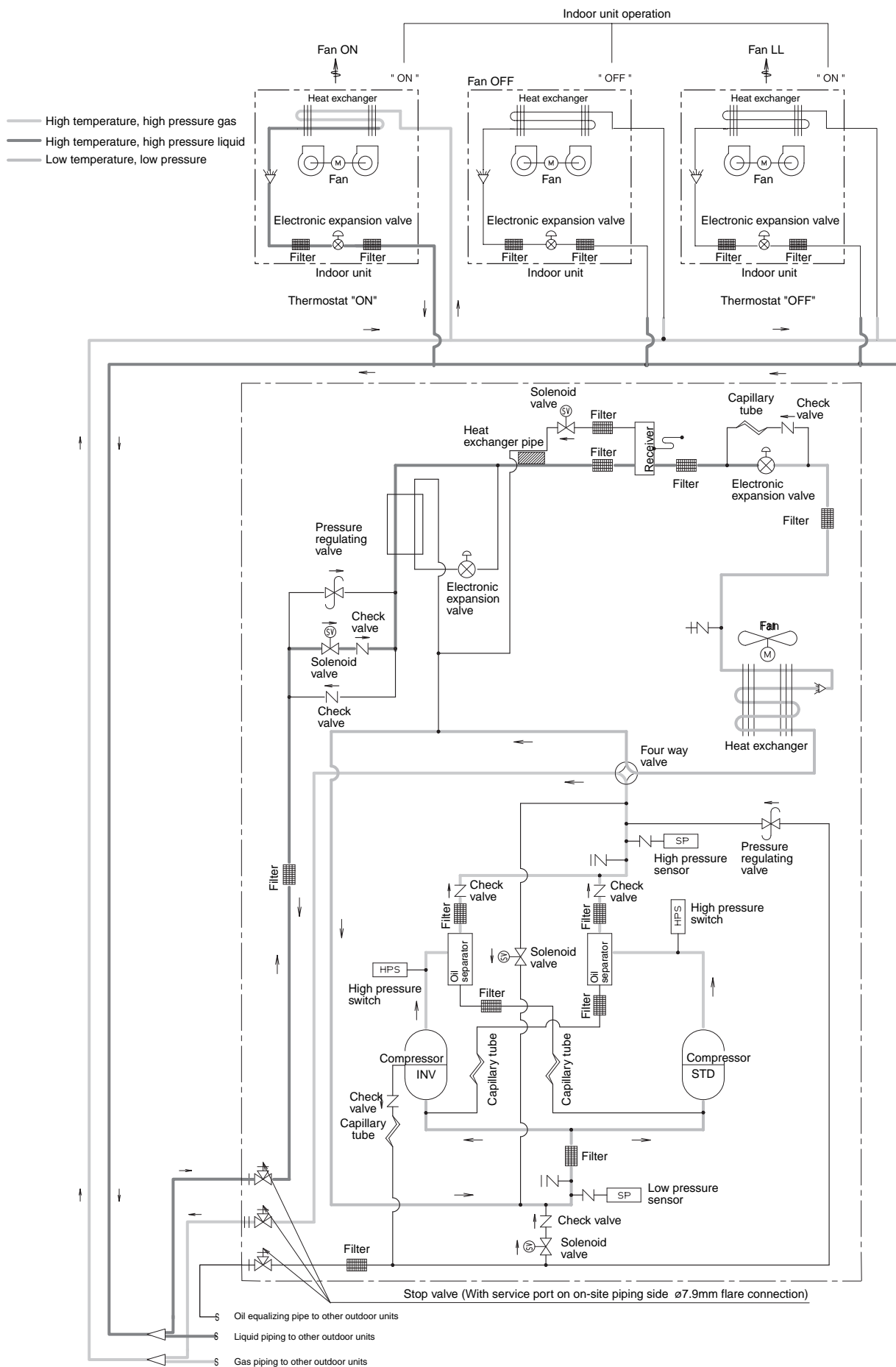

RXYQ14, 16M  
Cooling Operation

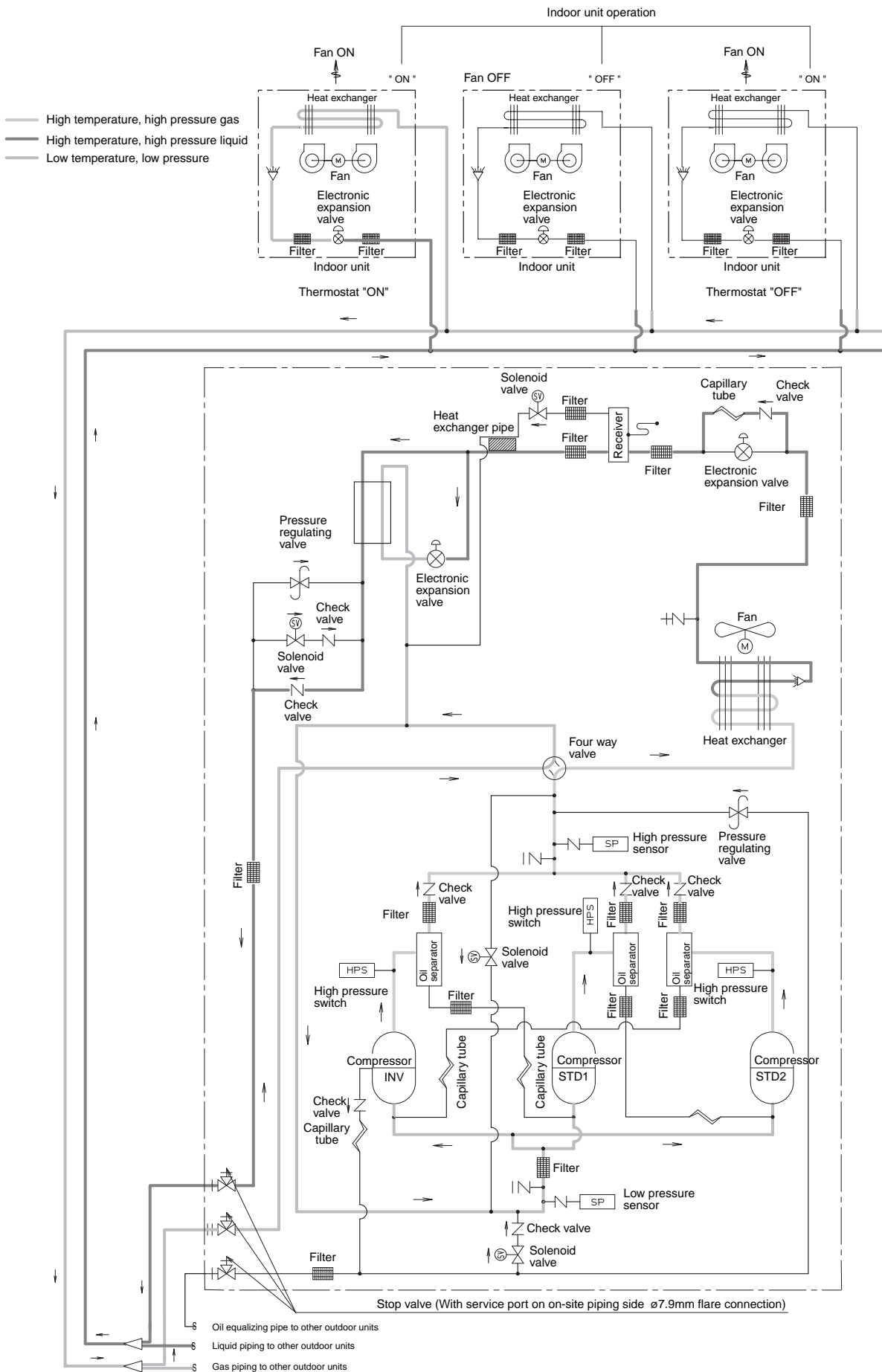

Cooling Oil Return Operation

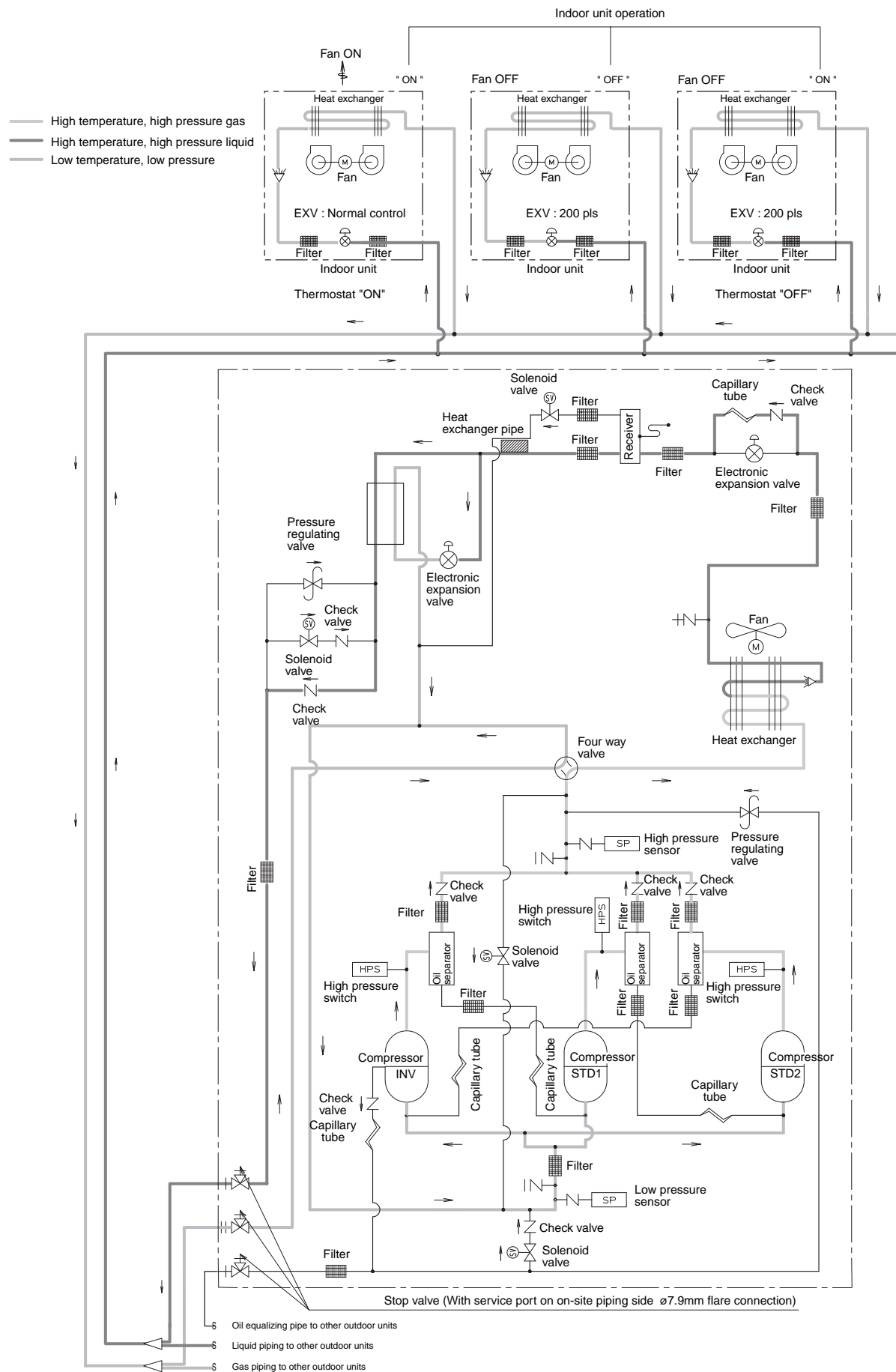



Heating Oil Return & Defrost Operation

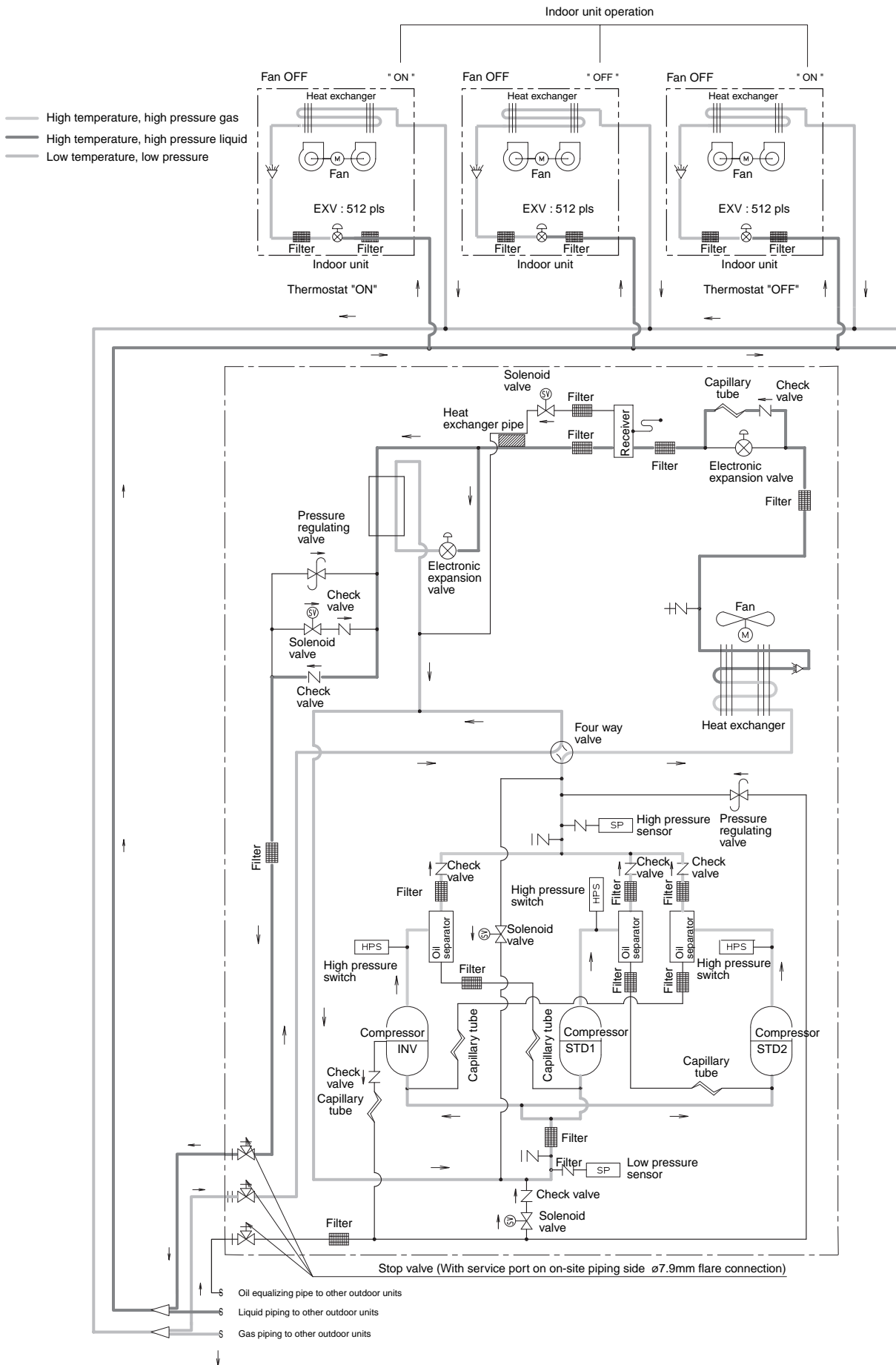





# Part 4

## Function

1. Function general .....	74
1.1 Symbol .....	74
1.2 Operation Mode.....	75
2. Basic Control .....	76
2.1 Normal Operation .....	76
2.2 Compressor PI Control.....	77
2.3 Electronic Expansion Valve PI Control.....	83
2.4 Cooling Operation Fan Control.....	84
3. Special Control.....	85
3.1 Startup Control .....	85
3.2 Oil Return Operation .....	86
3.3 Defrosting Operation .....	88
3.4 Pump-down Residual Operation .....	89
3.5 Restart Standby.....	90
3.6 Stopping Operation .....	91
3.7 Pressure Equalization prior to Startup.....	93
4. Protection Control .....	94
4.1 High Pressure Protection Control.....	94
4.2 Low Pressure Protection Control.....	95
4.3 Discharge Pipe Protection Control .....	96
4.4 Inverter Protection Control .....	97
4.5 STD Compressor Overload Protection.....	98
5. Other Control.....	99
5.1 Outdoor Unit Rotation.....	99
5.2 Emergency Operation .....	100
5.3 Demand Operation .....	102
5.4 Heating operation prohibition .....	102
6. Outline of Control (Indoor Unit) .....	103
6.1 Drain Pump Control.....	103
6.2 Louver Control for Preventing Ceiling Dirt.....	105
6.3 Thermostat Sensor in Remote Controller.....	106
6.4 Freeze Prevention .....	108
6.5 Control of outdoor air Processing unit (Unique Control for Outdoor Air Treatment) .....	109

# 1. Function general

## 1.1 Symbol

Symbol	Electric symbol	Description or function
20S1	Y1R	Four way valve (Energize during heating)
DSH	–	Discharge pie superheat
DSHi	–	Discharge pie superheat of inverter compressor
DSHs	–	Discharge pie superheat of standard compressor
EV	–	Opening of electronic expansion valve
EV1	Y1E	Electronic expansion valve for main heat exchanger
EV2	Y2E	Electronic expansion valve for sub-cooling heat exchanger
HTDi	–	Value of INV compressor discharge pie temperature (R31T) compensated with outdoor air temperature
HTDs	–	Value of STD compressor discharge pie temperature (R32T, R33T) compensated with outdoor air temperature
Pc	S1NPH	Value detected by high pressure sensor
Pe	S1NPL	Value detected by low pressure sensor
SH	–	Evaporator outlet superheat
SHS	–	Target evaporator outlet superheat
SVG	Y3S	Solenoid valve for discharging gas from receiver
SVO	Y2S	Solenoid valve for oil equalizing
SVP	Y1S	Solenoid valve for hot gas bypass
SVSL	Y4S	Solenoid valve for non-operating unit liquid pipe closing
Tb	R4T	Heat exchanger outlet temperature at cooling
Tc	–	High pressure equivalent saturation temperature
TcS	–	Target temperature of Tc
Te	–	Low pressure equivalent saturation temperature
TeS	–	Target temperature of Te
Tfin	R1T	Inverter fin temperature
Ts	R2T	Suction pie temperature detected by R2T
Tsh	R5T	Temperature detected by R5T
Tp	–	Calculated value of compressor port temperature

## 1.2 Operation Mode

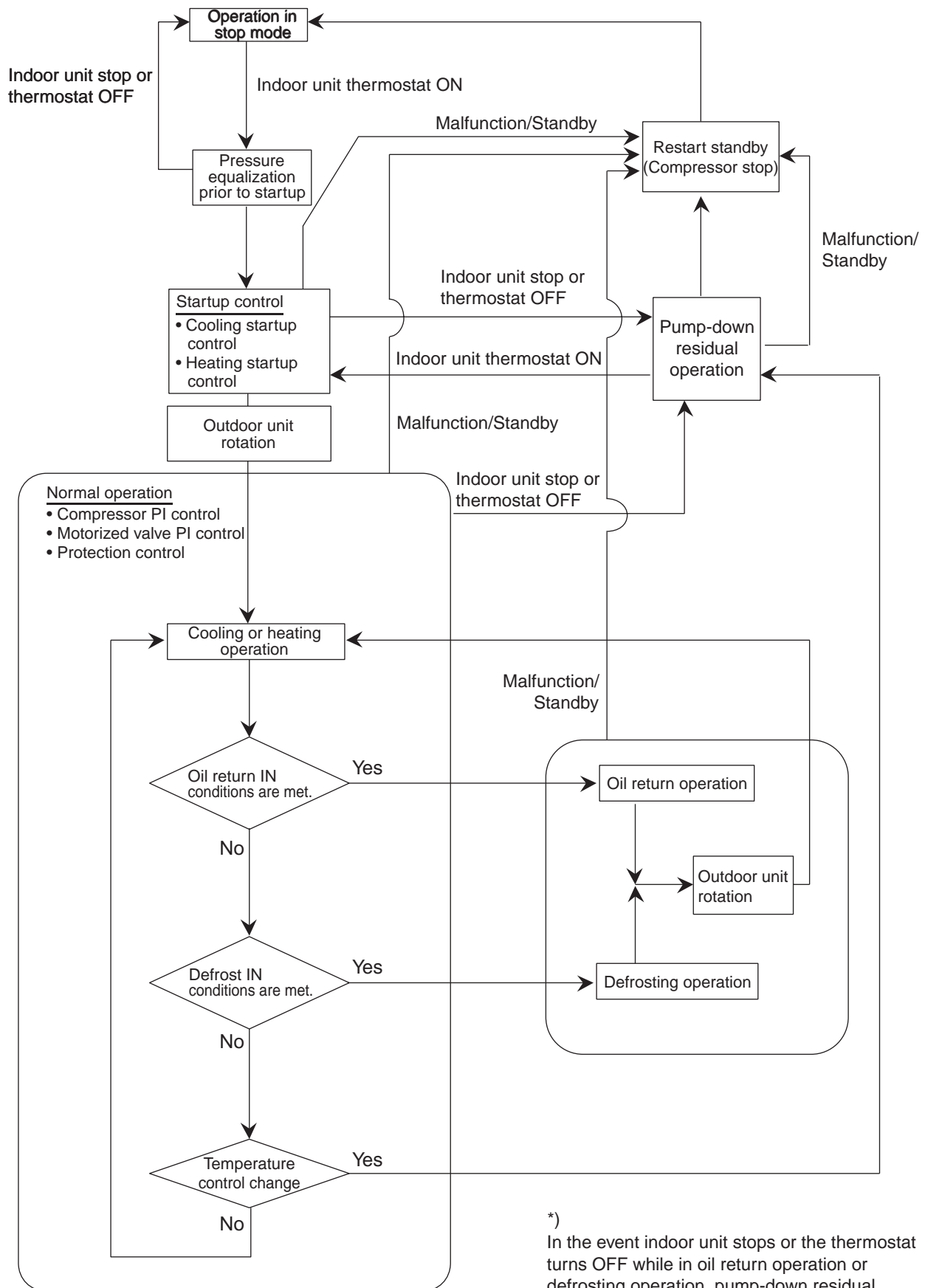

\*) In the event indoor unit stops or the thermostat turns OFF while in oil return operation or defrosting operation, pump-down residual operation is performed on completion of the oil return operation or defrosting operation.

## 2. Basic Control

### 2.1 Normal Operation

#### ■ Cooling Operation

Actuator	Operation	Remarks
Compressor	Compressor PI control	Used for high pressure protection control, low pressure protection control, discharge pipe temperature protection control, and compressor operating frequency upper limit control with inverter protection control.
Outdoor unit fan	Cooling fan control	—
Four way valve	OFF	—
Main motorized valve (EV1)	1400 pls	—
Subcooling motorized valve (EV2)	PI control	—
Hot gas bypass valve (SVP)	OFF	This valve turns on with low pressure protection control.
Oil equalization valve (SVO)	ON	In the case of multi-outdoor-unit system, this valve repeats ON/OFF operation at regular intervals of time.
Receiver gas discharging valve (SVG)	OFF	—
Non-operating unit liquid pipe stop valve (SVSL)	ON	—

#### ■ Heating Operation

Actuator	Operation	Remarks
Compressor	Compressor PI control	Used for high pressure protection control, low pressure protection control, discharge pipe temperature protection control, and compressor operating frequency upper limit control with inverter protection control.
Outdoor unit fan	STEP8 or 9	—
Four way valve	ON	—
Main motorized valve (EV1)	PI control	—
Subcooling motorized valve (EV2)	0 pls	—
Hot gas bypass valve (SVP)	OFF	This valve turns on with low pressure protection control.
Oil equalization valve (SVO)	ON	In the case of multi-outdoor-unit system, this valve repeats ON/OFF operation at regular intervals of time.
Receiver gas discharging valve (SVG)	OFF	—
Non-operating unit liquid pipe stop valve (SVSL)	ON	—

HHeating operation is not functional at an outdoor air temperature of 24°C or more.

## 2.2 Compressor PI Control

### Compressor PI Control

Carries out the compressor capacity PI control to maintain  $T_e$  at constant during cooling operation and  $T_c$  at constant during heating operation to ensure stable unit performance.

#### [Cooling operation]

Controls compressor capacity to adjust  $T_e$  to achieve target value ( $T_eS$ ).

##### Te setting

L	M (Normal) (factory setting)	H
3	6	9

$T_e$  : Low pressure equivalent saturation temperature (°C)

$T_eS$  : Target  $T_e$  value  
(Varies depending on  $T_e$  setting, operating frequency, etc.)

#### [Heating operation]

Controls compressor capacity to adjust  $T_c$  to achieve target value ( $T_cS$ ).

##### Tc setting

L	M (Normal) (factory setting)	H
43	46	49

$T_c$  : High pressure equivalent saturation temperature (°C)

$T_cS$  : Target  $T_c$  value  
(Varies depending on  $T_c$  setting, operating frequency, etc.)



■ Compressor Operating Priority

Each compressor operates in the following order of priority.  
 In the case of multi-outdoor-unit system, each compressor operates in any of Pattern 1 through Pattern 3 according to the rotation of outdoor units.

INV: Inverter compressor  
 STD1: Standard compressor 1  
 STD2: Standard compressor 2

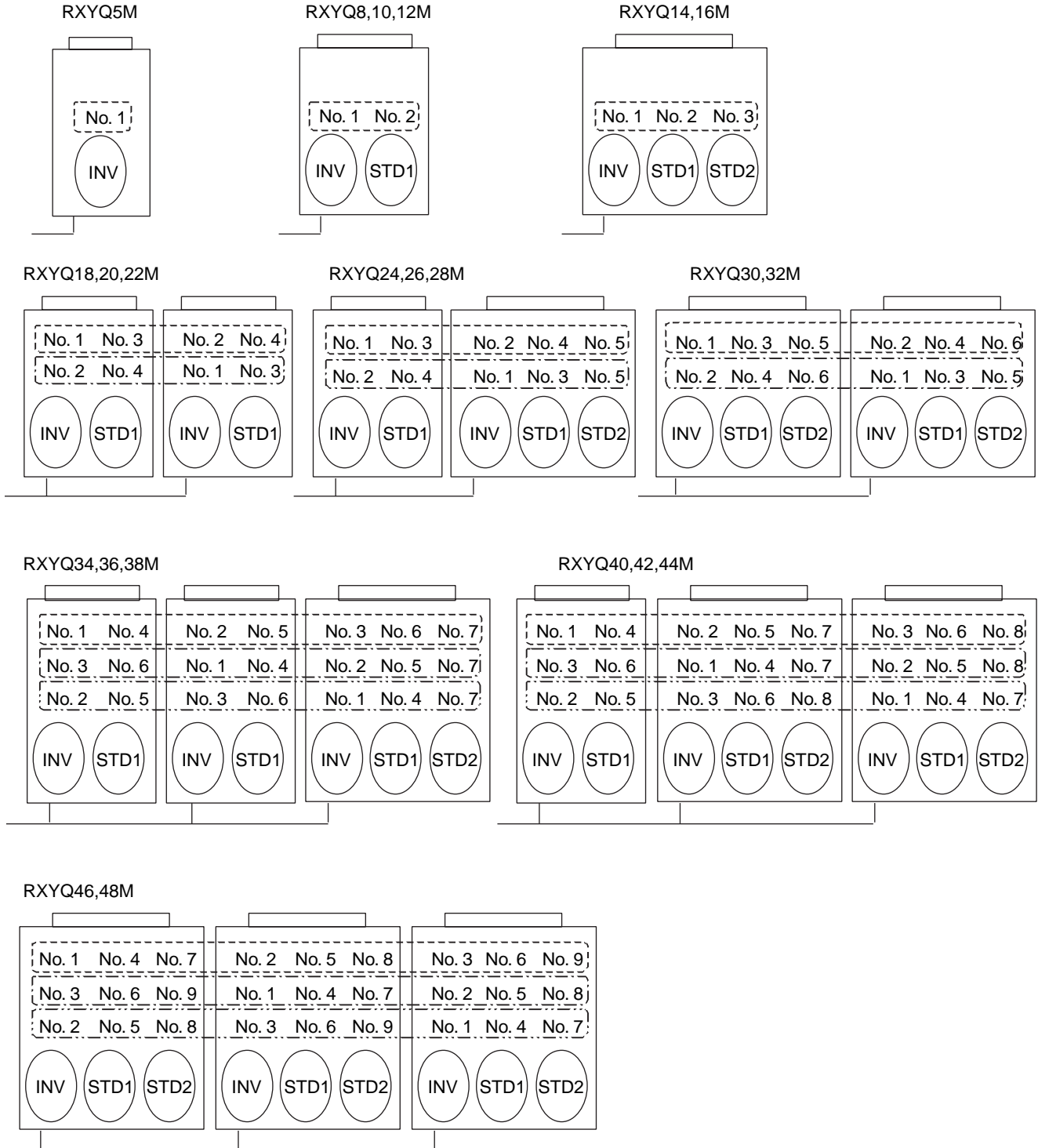
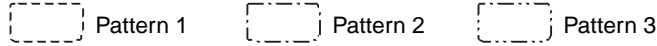

- \*
- In the case of combination of 3 outdoor units, the above diagram shows master unit, slave unit 1, and slave unit 2 from left to right.
  - Compressors may operate in any pattern other than those mentioned above according to the operating status.

## RXYQ5M

STEP	INV
1	52Hz
2	57Hz
3	62Hz
4	68Hz
5	74Hz
6	81Hz
7	88Hz
8	96Hz
9	104Hz
10	110Hz
11	116Hz
12	124Hz
13	133Hz
14	143Hz
15	158Hz
16	165Hz
17	177Hz
18	189Hz
19	202Hz
20	210Hz

## RXYQ8,10,12M

STEP	INV	STD1
1	52Hz	OFF
2	57Hz	OFF
3	62Hz	OFF
4	68Hz	OFF
5	74Hz	OFF
6	81Hz	OFF
7	88Hz	OFF
8	96Hz	OFF
9	104Hz	OFF
10	110Hz	OFF
11	116Hz	OFF
12	124Hz	OFF
13	133Hz	OFF
14	143Hz	OFF
15	158Hz	OFF
16	165Hz	OFF
17	177Hz	OFF
18	189Hz	OFF
19	202Hz	OFF
20	210Hz	OFF
21	52Hz	ON
22	74Hz	ON
23	96Hz	ON
24	116Hz	ON
25	133Hz	ON
26	158Hz	ON
27	177Hz	ON
28	202Hz	ON
29	210Hz	ON

## RXYQ14,16M

STEP	INV	STD1	STD2
1	52Hz	OFF	OFF
2	57Hz	OFF	OFF
3	62Hz	OFF	OFF
4	68Hz	OFF	OFF
5	74Hz	OFF	OFF
6	81Hz	OFF	OFF
7	88Hz	OFF	OFF
8	96Hz	OFF	OFF
9	104Hz	OFF	OFF
10	110Hz	OFF	OFF
11	116Hz	OFF	OFF
12	124Hz	OFF	OFF
13	133Hz	OFF	OFF
14	143Hz	OFF	OFF
15	158Hz	OFF	OFF
16	165Hz	OFF	OFF
17	177Hz	OFF	OFF
18	189Hz	OFF	OFF
19	202Hz	OFF	OFF
20	210Hz	OFF	OFF
21	52Hz	ON	OFF
22	74Hz	ON	OFF
23	96Hz	ON	OFF
24	116Hz	ON	OFF
25	133Hz	ON	OFF
26	158Hz	ON	OFF
27	177Hz	ON	OFF
28	202Hz	ON	OFF
29	210Hz	ON	OFF
30	52Hz	ON	ON
31	88Hz	ON	ON
32	124Hz	ON	ON
33	158Hz	ON	ON
34	189Hz	ON	ON
35*	210Hz	ON	ON

\*)Available only on 50Hz

## RXYQ18,20,22M

STEP	Master unit INV	Slave unit INV	STD unit No.1	STD unit No.2
1	52Hz	OFF	OFF	OFF
2	57Hz	OFF	OFF	OFF
3	62Hz	OFF	OFF	OFF
4	68Hz	OFF	OFF	OFF
5	74Hz	OFF	OFF	OFF
6	81Hz	OFF	OFF	OFF
7	88Hz	OFF	OFF	OFF
8	96Hz	OFF	OFF	OFF
9	104Hz	OFF	OFF	OFF
10	110Hz	OFF	OFF	OFF
11	116Hz	OFF	OFF	OFF
12	124Hz	OFF	OFF	OFF
13	133Hz	OFF	OFF	OFF
14	143Hz	OFF	OFF	OFF
15	158Hz	OFF	OFF	OFF
16	165Hz	OFF	OFF	OFF
17	177Hz	OFF	OFF	OFF
18	189Hz	OFF	OFF	OFF
19	202Hz	OFF	OFF	OFF
20	210Hz	OFF	OFF	OFF
21	52Hz	189Hz	OFF	OFF
22	74Hz	189Hz	OFF	OFF
23	96Hz	189Hz	OFF	OFF
24	116Hz	189Hz	OFF	OFF
25	133Hz	189Hz	OFF	OFF
26	158Hz	189Hz	OFF	OFF
27	177Hz	189Hz	OFF	OFF
28	202Hz	189Hz	OFF	OFF
29	210Hz	189Hz	OFF	OFF
30	52Hz	189Hz	ON	OFF
31	88Hz	189Hz	ON	OFF
32	124Hz	189Hz	ON	OFF
33	158Hz	189Hz	ON	OFF
34	189Hz	189Hz	ON	OFF
35	210Hz	189Hz	ON	OFF
36	52Hz	189Hz	ON	ON
37	88Hz	189Hz	ON	ON
38	124Hz	189Hz	ON	ON
39	158Hz	189Hz	ON	ON
40	189Hz	189Hz	ON	ON
41	210Hz	189Hz	ON	ON
42	210Hz	210Hz	ON	ON

## RXYQ24,26,28M

STEP	Master unit INV	Slave unit INV	STD unit No.1	STD unit No.2	STD unit No.3
1	52Hz	OFF	OFF	OFF	OFF
2	57Hz	OFF	OFF	OFF	OFF
3	62Hz	OFF	OFF	OFF	OFF
4	68Hz	OFF	OFF	OFF	OFF
5	74Hz	OFF	OFF	OFF	OFF
6	81Hz	OFF	OFF	OFF	OFF
7	88Hz	OFF	OFF	OFF	OFF
8	96Hz	OFF	OFF	OFF	OFF
9	104Hz	OFF	OFF	OFF	OFF
10	110Hz	OFF	OFF	OFF	OFF
11	116Hz	OFF	OFF	OFF	OFF
12	124Hz	OFF	OFF	OFF	OFF
13	133Hz	OFF	OFF	OFF	OFF
14	143Hz	OFF	OFF	OFF	OFF
15	158Hz	OFF	OFF	OFF	OFF
16	165Hz	OFF	OFF	OFF	OFF
17	177Hz	OFF	OFF	OFF	OFF
18	189Hz	OFF	OFF	OFF	OFF
19	202Hz	OFF	OFF	OFF	OFF
20	210Hz	OFF	OFF	OFF	OFF
21	52Hz	189Hz	OFF	OFF	OFF
22	74Hz	189Hz	OFF	OFF	OFF
23	96Hz	189Hz	OFF	OFF	OFF
24	116Hz	189Hz	OFF	OFF	OFF
25	133Hz	189Hz	OFF	OFF	OFF
26	158Hz	189Hz	OFF	OFF	OFF
27	177Hz	189Hz	OFF	OFF	OFF
28	202Hz	189Hz	OFF	OFF	OFF
29	210Hz	189Hz	OFF	OFF	OFF
30	52Hz	189Hz	ON	OFF	OFF
31	88Hz	189Hz	ON	OFF	OFF
32	124Hz	189Hz	ON	OFF	OFF
33	158Hz	189Hz	ON	OFF	OFF
34	189Hz	189Hz	ON	OFF	OFF
35	210Hz	189Hz	ON	OFF	OFF
36	52Hz	189Hz	ON	ON	OFF
37	88Hz	189Hz	ON	ON	OFF
38	124Hz	189Hz	ON	ON	OFF
39	158Hz	189Hz	ON	ON	OFF
40	189Hz	189Hz	ON	ON	OFF
41	210Hz	189Hz	ON	ON	OFF
42	52Hz	189Hz	ON	ON	ON
43	104Hz	189Hz	ON	ON	ON
44	143Hz	189Hz	ON	ON	ON
45	189Hz	189Hz	ON	ON	ON
46	210Hz	189Hz	ON	ON	ON
47	210Hz	210Hz	ON	ON	ON

- \*
- Compressors are operated in the order of descending priorities.
  - Compressors may operate in a pattern other than those listed in above tables subject to the operating conditions.
  - “Master unit”, and “slave unit” in this section are the names for control, and they will be transferred according to the priority of rotation system.

RXYQ30,32M

STEP	Master unit INV	Slave unit INV	STD unit No.1	STD unit No.2	STD unit No.3	STD unit No.4
1	52Hz	OFF	OFF	OFF	OFF	OFF
2	57Hz	OFF	OFF	OFF	OFF	OFF
3	62Hz	OFF	OFF	OFF	OFF	OFF
4	68Hz	OFF	OFF	OFF	OFF	OFF
5	74Hz	OFF	OFF	OFF	OFF	OFF
6	81Hz	OFF	OFF	OFF	OFF	OFF
7	88Hz	OFF	OFF	OFF	OFF	OFF
8	96Hz	OFF	OFF	OFF	OFF	OFF
9	104Hz	OFF	OFF	OFF	OFF	OFF
10	110Hz	OFF	OFF	OFF	OFF	OFF
11	116Hz	OFF	OFF	OFF	OFF	OFF
12	124Hz	OFF	OFF	OFF	OFF	OFF
13	133Hz	OFF	OFF	OFF	OFF	OFF
14	143Hz	OFF	OFF	OFF	OFF	OFF
15	158Hz	OFF	OFF	OFF	OFF	OFF
16	165Hz	OFF	OFF	OFF	OFF	OFF
17	177Hz	OFF	OFF	OFF	OFF	OFF
18	189Hz	OFF	OFF	OFF	OFF	OFF
19	202Hz	OFF	OFF	OFF	OFF	OFF
20	210Hz	OFF	OFF	OFF	OFF	OFF
21	52Hz	189Hz	OFF	OFF	OFF	OFF
22	74Hz	189Hz	OFF	OFF	OFF	OFF
23	96Hz	189Hz	OFF	OFF	OFF	OFF
24	116Hz	189Hz	OFF	OFF	OFF	OFF
25	133Hz	189Hz	OFF	OFF	OFF	OFF
26	158Hz	189Hz	OFF	OFF	OFF	OFF
27	177Hz	189Hz	OFF	OFF	OFF	OFF
28	202Hz	189Hz	OFF	OFF	OFF	OFF
29	210Hz	189Hz	OFF	OFF	OFF	OFF
30	52Hz	189Hz	ON	OFF	OFF	OFF
31	88Hz	189Hz	ON	OFF	OFF	OFF
32	124Hz	189Hz	ON	OFF	OFF	OFF
33	158Hz	189Hz	ON	OFF	OFF	OFF
34	189Hz	189Hz	ON	OFF	OFF	OFF
35	210Hz	189Hz	ON	OFF	OFF	OFF
36	52Hz	189Hz	ON	ON	OFF	OFF
37	88Hz	189Hz	ON	ON	OFF	OFF
38	124Hz	189Hz	ON	ON	OFF	OFF
39	158Hz	189Hz	ON	ON	OFF	OFF
40	189Hz	189Hz	ON	ON	OFF	OFF
41	210Hz	189Hz	ON	ON	OFF	OFF
42	52Hz	189Hz	ON	ON	ON	OFF
43	104Hz	189Hz	ON	ON	ON	OFF
44	143Hz	189Hz	ON	ON	ON	OFF
45	189Hz	189Hz	ON	ON	ON	OFF
46	210Hz	189Hz	ON	ON	ON	OFF
47	52Hz	189Hz	ON	ON	ON	ON
48	104Hz	189Hz	ON	ON	ON	ON
49	143Hz	189Hz	ON	ON	ON	ON
50	189Hz	189Hz	ON	ON	ON	ON
51	210Hz	189Hz	ON	ON	ON	ON
52	210Hz	210Hz	ON	ON	ON	ON

RXYQ34,36,38M

STEP	Master unit INV	Slave unit1 INV	Slave unit2 INV	STD unit No.1	STD unit No.2	STD unit No.3	STD unit No.4
1	52Hz	OFF	OFF	OFF	OFF	OFF	OFF
2	57Hz	OFF	OFF	OFF	OFF	OFF	OFF
3	62Hz	OFF	OFF	OFF	OFF	OFF	OFF
4	68Hz	OFF	OFF	OFF	OFF	OFF	OFF
5	74Hz	OFF	OFF	OFF	OFF	OFF	OFF
6	81Hz	OFF	OFF	OFF	OFF	OFF	OFF
7	88Hz	OFF	OFF	OFF	OFF	OFF	OFF
8	96Hz	OFF	OFF	OFF	OFF	OFF	OFF
9	104Hz	OFF	OFF	OFF	OFF	OFF	OFF
10	110Hz	OFF	OFF	OFF	OFF	OFF	OFF
11	116Hz	OFF	OFF	OFF	OFF	OFF	OFF
12	124Hz	OFF	OFF	OFF	OFF	OFF	OFF
13	133Hz	OFF	OFF	OFF	OFF	OFF	OFF
14	143Hz	OFF	OFF	OFF	OFF	OFF	OFF
15	158Hz	OFF	OFF	OFF	OFF	OFF	OFF
16	165Hz	OFF	OFF	OFF	OFF	OFF	OFF
17	177Hz	OFF	OFF	OFF	OFF	OFF	OFF
18	189Hz	OFF	OFF	OFF	OFF	OFF	OFF
19	202Hz	OFF	OFF	OFF	OFF	OFF	OFF
20	210Hz	OFF	OFF	OFF	OFF	OFF	OFF
21	52Hz	189Hz	OFF	OFF	OFF	OFF	OFF
22	74Hz	189Hz	OFF	OFF	OFF	OFF	OFF
23	96Hz	189Hz	OFF	OFF	OFF	OFF	OFF
24	116Hz	189Hz	OFF	OFF	OFF	OFF	OFF
25	133Hz	189Hz	OFF	OFF	OFF	OFF	OFF
26	158Hz	189Hz	OFF	OFF	OFF	OFF	OFF
27	177Hz	189Hz	OFF	OFF	OFF	OFF	OFF
28	202Hz	189Hz	OFF	OFF	OFF	OFF	OFF
29	210Hz	189Hz	OFF	OFF	OFF	OFF	OFF
30	52Hz	189Hz	189Hz	OFF	OFF	OFF	OFF
31	88Hz	189Hz	189Hz	OFF	OFF	OFF	OFF
32	124Hz	189Hz	189Hz	OFF	OFF	OFF	OFF
33	158Hz	189Hz	189Hz	OFF	OFF	OFF	OFF
34	189Hz	189Hz	189Hz	OFF	OFF	OFF	OFF
35	210Hz	189Hz	189Hz	OFF	OFF	OFF	OFF
36	52Hz	189Hz	189Hz	ON	OFF	OFF	OFF
37	88Hz	189Hz	189Hz	ON	OFF	OFF	OFF
38	124Hz	189Hz	189Hz	ON	OFF	OFF	OFF
39	158Hz	189Hz	189Hz	ON	OFF	OFF	OFF
40	189Hz	189Hz	189Hz	ON	OFF	OFF	OFF
41	210Hz	189Hz	189Hz	ON	OFF	OFF	OFF
42	52Hz	189Hz	189Hz	ON	ON	OFF	OFF
43	104Hz	189Hz	189Hz	ON	ON	OFF	OFF
44	143Hz	189Hz	189Hz	ON	ON	OFF	OFF
45	189Hz	189Hz	189Hz	ON	ON	OFF	OFF
46	210Hz	189Hz	189Hz	ON	ON	OFF	OFF
47	52Hz	189Hz	189Hz	ON	ON	ON	OFF
48	104Hz	189Hz	189Hz	ON	ON	ON	OFF
49	143Hz	189Hz	189Hz	ON	ON	ON	OFF
50	189Hz	189Hz	189Hz	ON	ON	ON	OFF
51	210Hz	189Hz	189Hz	ON	ON	ON	OFF
52	52Hz	189Hz	189Hz	ON	ON	ON	ON
53	104Hz	189Hz	189Hz	ON	ON	ON	ON
54	143Hz	189Hz	189Hz	ON	ON	ON	ON
55	189Hz	189Hz	189Hz	ON	ON	ON	ON
56	210Hz	189Hz	189Hz	ON	ON	ON	ON
57	210Hz	210Hz	210Hz	ON	ON	ON	ON

- \*
- Compressors are operated in the order of descending priorities.
  - Compressors may operate in a pattern other than those listed in above tables subject to the operating conditions.
  - “Master unit”, and “slave unit” in this section are the names for control, and they will be transferred according to the priority of rotation system.

## RXYQ40,42,44M

STEP	Master unit INV	Slave unit1 INV	Slave unit2 INV	STD unit No.1	STD unit No.2	STD unit No.3	STD unit No.4	STD unit No.5
1	52Hz	OFF	OFF	OFF	OFF	OFF	OFF	OFF
2	57Hz	OFF	OFF	OFF	OFF	OFF	OFF	OFF
3	62Hz	OFF	OFF	OFF	OFF	OFF	OFF	OFF
4	68Hz	OFF	OFF	OFF	OFF	OFF	OFF	OFF
5	74Hz	OFF	OFF	OFF	OFF	OFF	OFF	OFF
6	81Hz	OFF	OFF	OFF	OFF	OFF	OFF	OFF
7	88Hz	OFF	OFF	OFF	OFF	OFF	OFF	OFF
8	96Hz	OFF	OFF	OFF	OFF	OFF	OFF	OFF
9	104Hz	OFF	OFF	OFF	OFF	OFF	OFF	OFF
10	110Hz	OFF	OFF	OFF	OFF	OFF	OFF	OFF
11	116Hz	OFF	OFF	OFF	OFF	OFF	OFF	OFF
12	124Hz	OFF	OFF	OFF	OFF	OFF	OFF	OFF
13	133Hz	OFF	OFF	OFF	OFF	OFF	OFF	OFF
14	143Hz	OFF	OFF	OFF	OFF	OFF	OFF	OFF
15	158Hz	OFF	OFF	OFF	OFF	OFF	OFF	OFF
16	165Hz	OFF	OFF	OFF	OFF	OFF	OFF	OFF
17	177Hz	OFF	OFF	OFF	OFF	OFF	OFF	OFF
18	189Hz	OFF	OFF	OFF	OFF	OFF	OFF	OFF
19	202Hz	OFF	OFF	OFF	OFF	OFF	OFF	OFF
20	210Hz	OFF	OFF	OFF	OFF	OFF	OFF	OFF
21	52Hz	189Hz	OFF	OFF	OFF	OFF	OFF	OFF
22	74Hz	189Hz	OFF	OFF	OFF	OFF	OFF	OFF
23	96Hz	189Hz	OFF	OFF	OFF	OFF	OFF	OFF
24	116Hz	189Hz	OFF	OFF	OFF	OFF	OFF	OFF
25	133Hz	189Hz	OFF	OFF	OFF	OFF	OFF	OFF
26	158Hz	189Hz	OFF	OFF	OFF	OFF	OFF	OFF
27	177Hz	189Hz	OFF	OFF	OFF	OFF	OFF	OFF
28	202Hz	189Hz	OFF	OFF	OFF	OFF	OFF	OFF
29	210Hz	189Hz	OFF	OFF	OFF	OFF	OFF	OFF
30	52Hz	189Hz	189Hz	OFF	OFF	OFF	OFF	OFF
31	88Hz	189Hz	189Hz	OFF	OFF	OFF	OFF	OFF
32	124Hz	189Hz	189Hz	OFF	OFF	OFF	OFF	OFF
33	158Hz	189Hz	189Hz	OFF	OFF	OFF	OFF	OFF
34	189Hz	189Hz	189Hz	OFF	OFF	OFF	OFF	OFF
35	210Hz	189Hz	189Hz	OFF	OFF	OFF	OFF	OFF
36	52Hz	189Hz	189Hz	ON	OFF	OFF	OFF	OFF
37	88Hz	189Hz	189Hz	ON	OFF	OFF	OFF	OFF
38	124Hz	189Hz	189Hz	ON	OFF	OFF	OFF	OFF
39	158Hz	189Hz	189Hz	ON	OFF	OFF	OFF	OFF
40	189Hz	189Hz	189Hz	ON	OFF	OFF	OFF	OFF
41	210Hz	189Hz	189Hz	ON	OFF	OFF	OFF	OFF
42	52Hz	189Hz	189Hz	ON	ON	OFF	OFF	OFF
43	104Hz	189Hz	189Hz	ON	ON	OFF	OFF	OFF
44	143Hz	189Hz	189Hz	ON	ON	OFF	OFF	OFF
45	189Hz	189Hz	189Hz	ON	ON	OFF	OFF	OFF
46	210Hz	189Hz	189Hz	ON	ON	OFF	OFF	OFF
47	52Hz	189Hz	189Hz	ON	ON	ON	OFF	OFF
48	104Hz	189Hz	189Hz	ON	ON	ON	OFF	OFF
49	143Hz	189Hz	189Hz	ON	ON	ON	OFF	OFF
50	189Hz	189Hz	189Hz	ON	ON	ON	OFF	OFF
51	210Hz	189Hz	189Hz	ON	ON	ON	OFF	OFF
52	52Hz	189Hz	189Hz	ON	ON	ON	ON	OFF
53	104Hz	189Hz	189Hz	ON	ON	ON	ON	OFF
54	143Hz	189Hz	189Hz	ON	ON	ON	ON	OFF
55	189Hz	189Hz	189Hz	ON	ON	ON	ON	OFF
56	210Hz	189Hz	189Hz	ON	ON	ON	ON	OFF
57	52Hz	189Hz	189Hz	ON	ON	ON	ON	ON
58	104Hz	189Hz	189Hz	ON	ON	ON	ON	ON
59	143Hz	189Hz	189Hz	ON	ON	ON	ON	ON
60	189Hz	189Hz	189Hz	ON	ON	ON	ON	ON
61	210Hz	189Hz	189Hz	ON	ON	ON	ON	ON
62	210Hz	210Hz	210Hz	ON	ON	ON	ON	ON

- \*
- Compressors are operated in the order of descending priorities.
  - Compressors may operate in a pattern other than those listed in above tables subject to on the operating conditions.
  - “Master unit”, “slave unit 1” and “slave unit 2” in this section, are the names for control, and they will be transferred according to the priority of rotation system.

## RXYQ46,48M

STEP	Master unit INV	Slave unit1 INV	Slave unit2 INV	STD unit No.1	STD unit No.2	STD unit No.3	STD unit No.4	STD unit No.5	STD unit No.6
1	52Hz	OFF	OFF	OFF	OFF	OFF	OFF	OFF	OFF
2	57Hz	OFF	OFF	OFF	OFF	OFF	OFF	OFF	OFF
3	62Hz	OFF	OFF	OFF	OFF	OFF	OFF	OFF	OFF
4	68Hz	OFF	OFF	OFF	OFF	OFF	OFF	OFF	OFF
5	74Hz	OFF	OFF	OFF	OFF	OFF	OFF	OFF	OFF
6	81Hz	OFF	OFF	OFF	OFF	OFF	OFF	OFF	OFF
7	88Hz	OFF	OFF	OFF	OFF	OFF	OFF	OFF	OFF
8	96Hz	OFF	OFF	OFF	OFF	OFF	OFF	OFF	OFF
9	104Hz	OFF	OFF	OFF	OFF	OFF	OFF	OFF	OFF
10	110Hz	OFF	OFF	OFF	OFF	OFF	OFF	OFF	OFF
11	116Hz	OFF	OFF	OFF	OFF	OFF	OFF	OFF	OFF
12	124Hz	OFF	OFF	OFF	OFF	OFF	OFF	OFF	OFF
13	133Hz	OFF	OFF	OFF	OFF	OFF	OFF	OFF	OFF
14	143Hz	OFF	OFF	OFF	OFF	OFF	OFF	OFF	OFF
15	158Hz	OFF	OFF	OFF	OFF	OFF	OFF	OFF	OFF
16	165Hz	OFF	OFF	OFF	OFF	OFF	OFF	OFF	OFF
17	177Hz	OFF	OFF	OFF	OFF	OFF	OFF	OFF	OFF
18	189Hz	OFF	OFF	OFF	OFF	OFF	OFF	OFF	OFF
19	202Hz	OFF	OFF	OFF	OFF	OFF	OFF	OFF	OFF
20	210Hz	OFF	OFF	OFF	OFF	OFF	OFF	OFF	OFF
21	52Hz	189Hz	OFF	OFF	OFF	OFF	OFF	OFF	OFF
22	74Hz	189Hz	OFF	OFF	OFF	OFF	OFF	OFF	OFF
23	96Hz	189Hz	OFF	OFF	OFF	OFF	OFF	OFF	OFF
24	116Hz	189Hz	OFF	OFF	OFF	OFF	OFF	OFF	OFF
25	133Hz	189Hz	OFF	OFF	OFF	OFF	OFF	OFF	OFF
26	158Hz	189Hz	OFF	OFF	OFF	OFF	OFF	OFF	OFF
27	177Hz	189Hz	OFF	OFF	OFF	OFF	OFF	OFF	OFF
28	202Hz	189Hz	OFF	OFF	OFF	OFF	OFF	OFF	OFF
29	210Hz	189Hz	OFF	OFF	OFF	OFF	OFF	OFF	OFF
30	52Hz	189Hz	189Hz	OFF	OFF	OFF	OFF	OFF	OFF
31	88Hz	189Hz	189Hz	OFF	OFF	OFF	OFF	OFF	OFF
32	124Hz	189Hz	189Hz	OFF	OFF	OFF	OFF	OFF	OFF
33	158Hz	189Hz	189Hz	OFF	OFF	OFF	OFF	OFF	OFF
34	189Hz	189Hz	189Hz	OFF	OFF	OFF	OFF	OFF	OFF
35	210Hz	189Hz	189Hz	OFF	OFF	OFF	OFF	OFF	OFF
36	52Hz	189Hz	189Hz	ON	OFF	OFF	OFF	OFF	OFF
37	88Hz	189Hz	189Hz	ON	OFF	OFF	OFF	OFF	OFF
38	124Hz	189Hz	189Hz	ON	OFF	OFF	OFF	OFF	OFF
39	158Hz	189Hz	189Hz	ON	OFF	OFF	OFF	OFF	OFF
40	189Hz	189Hz	189Hz	ON	OFF	OFF	OFF	OFF	OFF
41	210Hz	189Hz	189Hz	ON	OFF	OFF	OFF	OFF	OFF
42	52Hz	189Hz	189Hz	ON	ON	OFF	OFF	OFF	OFF
43	104Hz	189Hz	189Hz	ON	ON	OFF	OFF	OFF	OFF
44	143Hz	189Hz	189Hz	ON	ON	OFF	OFF	OFF	OFF
45	189Hz	189Hz	189Hz	ON	ON	OFF	OFF	OFF	OFF
46	210Hz	189Hz	189Hz	ON	ON	OFF	OFF	OFF	OFF
47	52Hz	189Hz	189Hz	ON	ON	ON	OFF	OFF	OFF
48	104Hz	189Hz	189Hz	ON	ON	ON	OFF	OFF	OFF
49	143Hz	189Hz	189Hz	ON	ON	ON	OFF	OFF	OFF
50	189Hz	189Hz	189Hz	ON	ON	ON	OFF	OFF	OFF
51	210Hz	189Hz	189Hz	ON	ON	ON	OFF	OFF	OFF
52	52Hz	189Hz	189Hz	ON	ON	ON	ON	OFF	OFF
53	104Hz	189Hz	189Hz	ON	ON	ON	ON	OFF	OFF
54	143Hz	189Hz	189Hz	ON	ON	ON	ON	OFF	OFF
55	189Hz	189Hz	189Hz	ON	ON	ON	ON	OFF	OFF
56	210Hz	189Hz	189Hz	ON	ON	ON	ON	OFF	OFF
57	52Hz	189Hz	189Hz	ON	ON	ON	ON	ON	OFF
58	104Hz	189Hz	189Hz	ON	ON	ON	ON	ON	OFF
59	143Hz	189Hz	189Hz	ON	ON	ON	ON	ON	OFF
60	189Hz	189Hz	189Hz	ON	ON	ON	ON	ON	OFF
61	210Hz	189Hz	189Hz	ON	ON	ON	ON	ON	OFF
62	52Hz	189Hz	189Hz	ON	ON	ON	ON	ON	ON
63	104Hz	189Hz	189Hz	ON	ON	ON	ON	ON	ON
64	143Hz	189Hz	189Hz	ON	ON	ON	ON	ON	ON
65	189Hz	189Hz	189Hz	ON	ON	ON	ON	ON	ON
66	210Hz	189Hz	189Hz	ON	ON	ON	ON	ON	ON
67*	210Hz	210Hz	210Hz	ON	ON	ON	ON	ON	ON

\*) Only for 50Hz

- \*
- Compressors are operated in the order of descending priorities.
  - Compressors may operate in a pattern other than those listed in above tables subject to on the operating conditions.
  - "Master unit", "slave unit 1" and "slave unit 2" in this section are the names for control, and they will be transferred according to the priority of rotation system.

## 2.3 Electronic Expansion Valve PI Control

---

### Main Motorized Valve EV1 Control

Carries out the motorized valve (Y1E) PI control to maintain the evaporator outlet superheated degree (SH) at constant during heating operation to make maximum use of the outdoor unit heat exchanger (evaporator).

$$SH = T_s - T_e$$

SH : Evaporator outlet superheated degree (°C)

T<sub>s</sub> : Suction pipe temperature detected by thermistor R2T (°C)

T<sub>e</sub> : Low pressure equivalent saturation temperature (°C)

The optimum initial value of the evaporator outlet superheated degree is 5°C, but varies depending on the discharge pipe superheated degree of inverter compressor.

---

### Subcooling Motorized Valve EV2 Control

Makes PI control of the motorized valve (Y2E) to keep the superheated degree of the outlet gas pipe on the evaporator side for the full use of the subcooling heat exchanger.

$$SH = T_{sh} - T_e$$

SH : Outlet superheated degree of evaporator (°C)

T<sub>sh</sub> : Suction pipe temperature detected with the thermistor R5T (°C)

T<sub>e</sub> : Low pressure equivalent saturation temperature (°C)

## 2.4 Cooling Operation Fan Control

In cooling operation with low outdoor air temperature, this control is used to provide the adequate amount of circulation air with liquid pressure secured by high pressure control using outdoor unit fan.

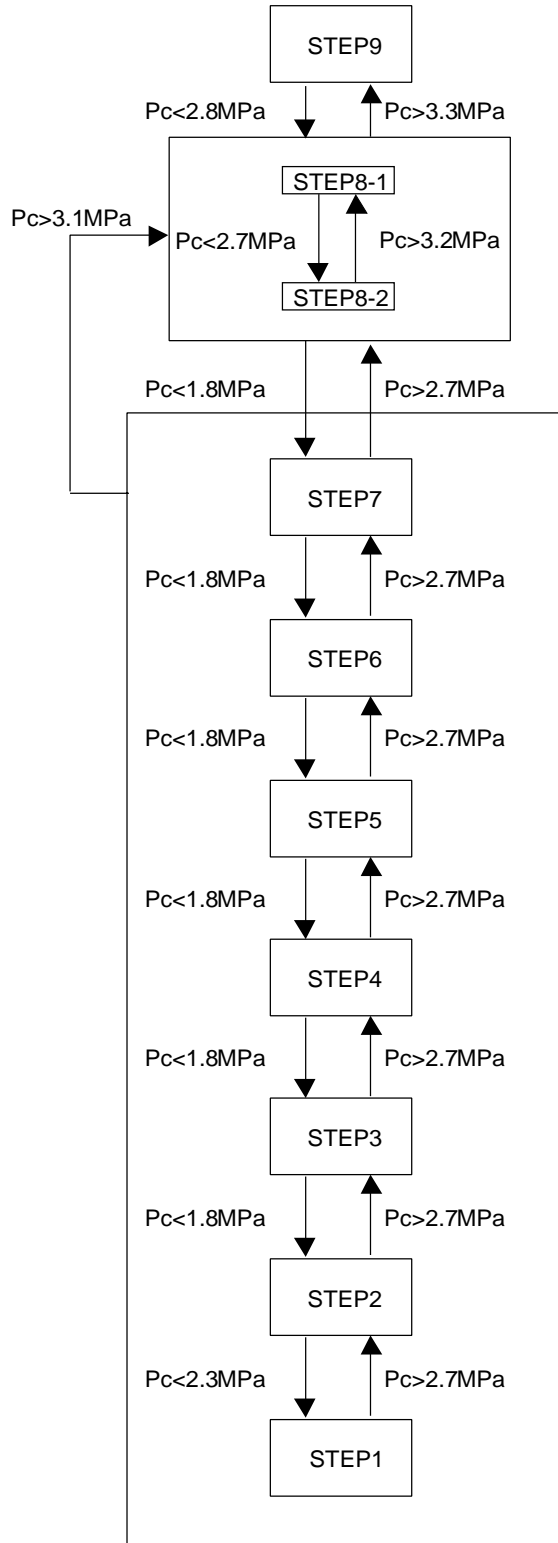

Pc: HP pressure sensor detection value

Fan Steps

	RXYQ5M	RXYQ 8 and 10M	RXYQ 12 to 16M
STEP1	0rpm	0rpm	0rpm
STEP2	300rpm	300rpm	300rpm
STEP3	320rpm	320rpm	325rpm
STEP4	350rpm	345rpm	355rpm
STEP5	385rpm	385rpm	400rpm
STEP6	470rpm	465rpm	500rpm
STEP7	585rpm	575rpm	630rpm
STEP8-2	800rpm	660rpm	710rpm
STEP8-1	800rpm	785rpm	880rpm
STEP9	840rpm	825rpm	920rpm

## 3. Special Control

### 3.1 Startup Control

#### 3.1.1 Startup Control in Cooling Operation

Actuator	Operation	Remarks
Compressor	Differential pressure control	Compressor operating frequency increases by 1 step / 20 sec until $P_c - P_e > 0.4$ MPa.
Outdoor unit fan	High pressure control	Initial compressor operating frequency is set to STEP 1. 1-step increase with $P_c > 2.2$ MPa 1-step decrease with $P_c < 1.8$ MPa
Four way valve	OFF	—
Main motorized valve (EV1)	1400 pls	—
Subcooling motorized valve (EV2)	0 pls	—
Hot gas bypass valve (SVP)	ON	—
Oil equalization valve (SVO)	ON	In the case of multi-outdoor-unit system, this valve repeats ON/OFF operation at regular intervals of time to equalize the oil level of each outdoor unit.
Receiver gas discharging valve (SVG)	OFF	—
Non-operating unit liquid pipe stop valve (SVSL)	ON	—
Ending conditions	or $\left[ \begin{array}{l} \bullet 200 \text{ sec.} \\ \bullet P_c - P_e > 0.4 \text{ MPa} \end{array} \right.$	

\* In the case of multi-outdoor-unit system, both master and slave units perform the operations listed in the table above.

\* Actuators are based on RXYQ16M.

#### 3.1.2 Startup Control in Heating Operation

Actuator	Operation	Remarks
Compressor	Differential pressure control	Compressor operating frequency increases by 1 step / 20 sec until $P_c - P_e > 0.4$ MPa.
Outdoor unit fan	STEP9	—
Four way valve	ON	—
Main motorized valve (EV1)	200 pls	—
Subcooling motorized valve (EV2)	0 pls	—
Hot gas bypass valve (SVP)	ON	—
Oil equalization valve (SVO)	ON	In the case of multi-outdoor-unit system, this valve repeats ON/OFF operation at regular intervals of time to equalize the oil level of each outdoor unit.
Receiver gas discharging valve (SVG)	OFF	—
Non-operating unit liquid pipe stop valve (SVSL)	ON	—
Ending conditions	or $\left[ \begin{array}{l} \bullet 200 \text{ sec.} \\ \bullet P_c - P_e > 0.4 \text{ MPa} \end{array} \right.$	

\* In the case of multi-outdoor-unit system, both master and slave units perform the operations listed in the table above.

\* Actuators are based on RXYQ16M.



## 3.2 Oil Return Operation

### 3.2.1 Oil Return Operation in Cooling Operation

Outdoor unit actuator	Oil return preparation operation	Oil return operation	Post-oil-return operation
Compressor	Upper limit control	124 Hz + ON + OFF	52 Hz + OFF + OFF
Outdoor unit fan	Fan control	Fan control	Fan control
Four way valve	OFF	OFF	OFF
Main motorized valve (EV1)	1400 pls	1400 pls	1400 pls
Subcooling motorized valve (EV2)	SH control	0 pls	0 pls
Hot gas bypass valve (SVP)	OFF	ON	ON
Oil equalization valve (SVO)	ON	ON	ON
Receiver gas discharging valve (SVG)	OFF	OFF	OFF
Non-operating unit liquid pipe stop valve (SVSL)	ON	ON	ON
Ending conditions	2 min.	or $\left\{ \begin{array}{l} \bullet 6 \text{ min.} \\ \bullet T_s - T_e < 5 \end{array} \right.$	10 sec.

\* In the case of multi-outdoor-unit system,

Master unit: Performs the operations listed in the table above.

Slave units: Operating units perform the operations listed in the table above.

Non-operating units perform the operations listed in the table above from the oil return operation.

(Non-operating unit stops during "oil return preparation operation".)

\* Actuators are based on RXYQ16M.

Indoor unit actuator		Cooling oil return operation
Fan	Thermostat ON unit	Set Air Volume
	Stopping unit	OFF
	Thermostat OFF unit	OFF
Electronic expansion valve	Thermostat ON unit	Normal opening
	Stopping unit	200 pls
	Thermostat OFF unit	200 pls

### 3.2.2 Oil Return Operation in Heating Operation

Outdoor Unit Actuator	Oil return preparation operation	Oil return operation	Post-oil-return operation
Compressor	Upper limit control	124 Hz + ON + OFF	1-step increase from (74 Hz + OFF + OFF) to (Pc - Pe>0.4 MPa) time
Outdoor unit fan	STEP8 or STEP9	OFF	STEP9
Four way valve	ON	OFF	ON
Main motorized valve (EV1)	SH control	1400 pls	180 pls
Subcooling motorized valve (EV2)	0 pls	0 pls	0 pls
Hot gas bypass valve (SVP)	OFF	ON	ON
Oil equalization valve (SVO)	ON	ON	ON
Receiver gas discharging valve (SVG)	OFF	OFF	OFF
Non-operating unit liquid pipe stop valve (SVSL)	ON	ON	ON
Ending conditions	2 min.	or [ <ul style="list-style-type: none"> <li>• 6 min.</li> <li>• Ts - Te&lt;5</li> </ul>	or [ <ul style="list-style-type: none"> <li>• 160 sec.</li> <li>• Pc - Pe&gt;0.4MPa</li> </ul>

\* In the case of multi-outdoor-unit system,

Master unit: Performs the operations listed in the table above.

Slave units: Operating units perform the operations listed in the table above.

Non-operating units perform the operations listed in the table above from the oil return operation.

(Non-operating unit stops during "oil return preparation operation".)

\* Actuators are based on RXYQ16M.

Indoor unit actuator		Heating oil return operation
Fan	Thermostat ON unit	OFF
	Stopping unit	OFF
	Thermostat OFF unit	OFF
Electronic expansion valve	Thermostat ON unit	512 pls
	Stopping unit	512 pls
	Thermostat OFF unit	512 pls

<In condition of oil return operation>

Compressor cumulative operation time > 8 hours

(However, 2 hours after turning power on first time.)

### 3.3 Defrosting Operation

Outdoor unit actuator	Defrost preparation operation	Defrost operation	Post Defrost operation
Compressor	Upper limit control	143 Hz + ON + ON	1-step increase from (74 Hz + OFF + OFF) to (Pc - Pe > 0.4 MPa)
Outdoor unit fan	STEP8 or STEP9	OFF	STEP9
Four way valve	ON	OFF	ON
Main motorized valve (EV1)	SH control	1400 pls	200 pls
Subcooling motorized valve (EV2)	0 pls	0 pls	0 pls
Hot gas bypass valve (SVP)	OFF	ON	ON
Oil equalization valve (SVO)	ON	ON	ON
Receiver gas discharging valve (SVG)	OFF	OFF	OFF
Non-operating unit liquid pipe stop valve (SVSL)	ON	ON	ON
Ending conditions	2 min.	or [ <ul style="list-style-type: none"> <li>• 12 min.</li> <li>• Ts &gt; 11°C</li> </ul>	or [ <ul style="list-style-type: none"> <li>• 160 sec.</li> <li>• Pc - Pe &gt; 0.4MPa</li> </ul>

\* In the case of multi-outdoor-unit system,

Master unit: Performs the operations listed in the table above.

Slave units: Operating units perform the operations listed in the table above.

Non-operating units perform the operations listed in the table above from the Defrost operation.

(Non-operating unit stops during "Defrost preparation operation".)

\* Actuators are based on RXYQ16M.

Indoor unit actuator		During defrost
Fan	Thermostat ON unit	OFF
	Stopping unit	OFF
	Thermostat OFF unit	OFF
Electronic expansion valve	Thermostat ON unit	512 pls
	Stopping unit	512 pls
	Thermostat OFF unit	512 pls

<Defrost starting condition>

Defrost operation is started when the outdoor heat exchanger temperature becomes lower than deicer temperature.

Defrost operation is conducted once in max. 2 hours.

## 3.4 Pump-down Residual Operation

### 3.4.1 Pump-down Residual Operation in Cooling Operation

Actuator	Master unit operation	Slave unit operation
Compressor	210 Hz + OFF + OFF	OFF
Outdoor unit fan	Fan control	OFF
Four way valve	OFF	OFF
Main motorized valve (EV1)	1400 pls	0 pls
Subcooling motorized valve (EV2)	0 pls	0 pls
Hot gas bypass valve (SVP)	ON	OFF
Oil equalization valve (SVO)	ON	OFF
Receiver gas discharging valve (SVG)	ON	ON
Non-operating unit liquid pipe stop valve (SVSL)	ON	ON
Ending conditions	or [ <ul style="list-style-type: none"> <li>• 5 min.</li> <li>• Pe&lt;0.5 MPa</li> <li>• Td&gt;110°C</li> </ul>	

\* Actuators are based on RXYQ16M.

### 3.4.2 Pump-down Residual Operation in Heating Operation

Actuator	Master unit operation	Slave unit operation
Compressor	124 Hz + OFF + OFF	OFF
Outdoor unit fan	STEP8	STEP5
Four way valve	ON	ON
Main motorized valve (EV1)	0 pls	0 pls
Subcooling motorized valve (EV2)	0 pls	0 pls
Hot gas bypass valve (SVP)	ON	OFF
Oil equalization valve (SVO)	ON	OFF
Receiver gas discharging valve (SVG)	ON	ON
Non-operating unit liquid pipe stop valve (SVSL)	ON	ON
Ending conditions	or [ <ul style="list-style-type: none"> <li>• 30 sec.</li> <li>• Pe&lt;0.25 MPa</li> <li>• Td&gt;110°C</li> </ul>	

\* Actuators are based on RXYQ16M.

### 3.5 Restart Standby

Actuator	Operation	Remarks
Compressor	OFF	—
Outdoor unit fan	Ta>30°C: STEP5 Ta≤30°C: OFF	—
Four way valve	Holds ON	—
Main motorized valve (EV1)	0 pls	—
Subcooling motorized valve (EV2)	0 pls	—
Hot gas bypass valve (SVP)	OFF	In the case of RXYQ5M , this valve turns ON.
Oil equalization valve (SVO)	ON	In the case of slave units, this valve turns OFF.
Receiver gas discharging valve (SVG)	OFF	—
Non-operating unit liquid pipe stop valve (SVSL)	ON	—
Ending conditions	5 min.	—

\* Actuators are based on RXYQ16M.

## 3.6 Stopping Operation

### 3.6.1 When System is in Stop Mode

Actuator	Operation
Compressor	OFF
Outdoor unit fan	OFF
Four way valve	Holds ON
Main motorized valve (EV1)	0 pls
Subcooling motorized valve (EV2)	0 pls
Hot gas bypass valve (SVP)	OFF
Oil equalization valve (SVO)	OFF
Receiver gas discharging valve (SVG)	OFF
Non-operating unit liquid pipe stop valve (SVSL)	ON
Ending conditions	Indoor unit thermostat is turned ON.

\* Actuators are based on RXYQ16M.

### 3.6.2 Stopping Operation of Slave Units During Master Unit is in Operation With Multi-Outdoor-Unit System

In cooling operation: The system operates in Mode A or Mode B listed in the table below.

Actuator	Mode-A operation	Mode-B operation
Compressor	OFF	OFF
Outdoor unit fan	STEP4	OFF
Four way valve	OFF	Holds ON
Main motorized valve (EV1)	150 pls to 300 pls	0 pls
Subcooling motorized valve (EV2)	0 pls	0 pls
Hot gas bypass valve (SVP)	ON	ON
Oil equalization valve (SVO)	OFF	OFF
Receiver gas discharging valve (SVG)	OFF	OFF
Non-operating unit liquid pipe stop valve (SVSL)	OFF	ON
Mode transition conditions	To Mode B when $T_c - T_l > 0.27 \times (T_c - T_a) + 6$	To Mode A when gas shortage signal is sent from indoor unit
Ending conditions	Slave units are required to operate.	

In heating operation: The system operates in Mode A or Mode B listed in the table below.

Actuator	Mode-A operation	Mode-B operation
Compressor	OFF	OFF
Outdoor unit fan	STEP2	STEP2
Four way valve	ON	ON
Main motorized valve (EV1)	0 pls	0 pls
Subcooling motorized valve (EV2)	0 pls	0 pls
Hot gas bypass valve (SVP)	OFF	OFF
Oil equalization valve (SVO)	OFF	OFF
Receiver gas discharging valve (SVG)	OFF	OFF
Non-operating unit liquid pipe stop valve (SVSL)	OFF	ON
Mode transition conditions	To Mode B when $T_c - \text{mean temperature of indoor unit liquid pipes} > 10^\circ\text{C}$	To Mode A when motorized valve of operating outdoor unit fully opens.
Ending conditions	Slave units are required to operate.	

\* Mode A or B operation

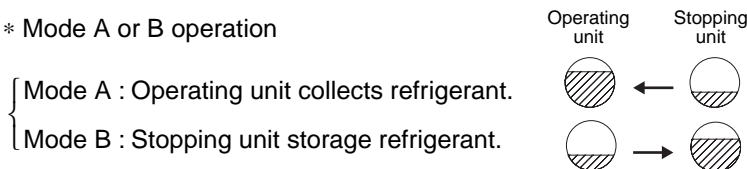

The changeover operation for mode A and B is performed for the reason that the required refrigerant amount varies depending on the indoor unit operation capacity.

### 3.7 Pressure Equalization prior to Startup

Actuator	Operation	Remarks
Compressor	OFF	—
Outdoor unit fan	Cooling:OFF Heating:STEP 4	—
Four way valve	Holds ON	—
Main motorized valve (EV1)	0 pls	—
Subcooling motorized valve (EV2)	0 pls	—
Hot gas bypass valve (SVP)	OFF	In the case of RXYQ5M, this valve turns ON.
Oil equalization valve (SVO)	OFF	—
Receiver gas discharging valve (SVG)	OFF	—
Non-operating unit liquid pipe stop valve (SVSL)	OFF	—
Ending conditions	10 sec.	In the case of RXYQ5M, 3 min. or $P_c - P_e < 0.2$ MPa



# 4. Protection Control

## 4.1 High Pressure Protection Control

This high pressure protection control is used to prevent the activation of protection devices due to abnormal increase of high pressure and to protect compressors against the transient increase of high pressure.

[In cooling operation]

H In the case of multi-outdoor-unit system, each outdoor unit performs this control individually in the following sequence.

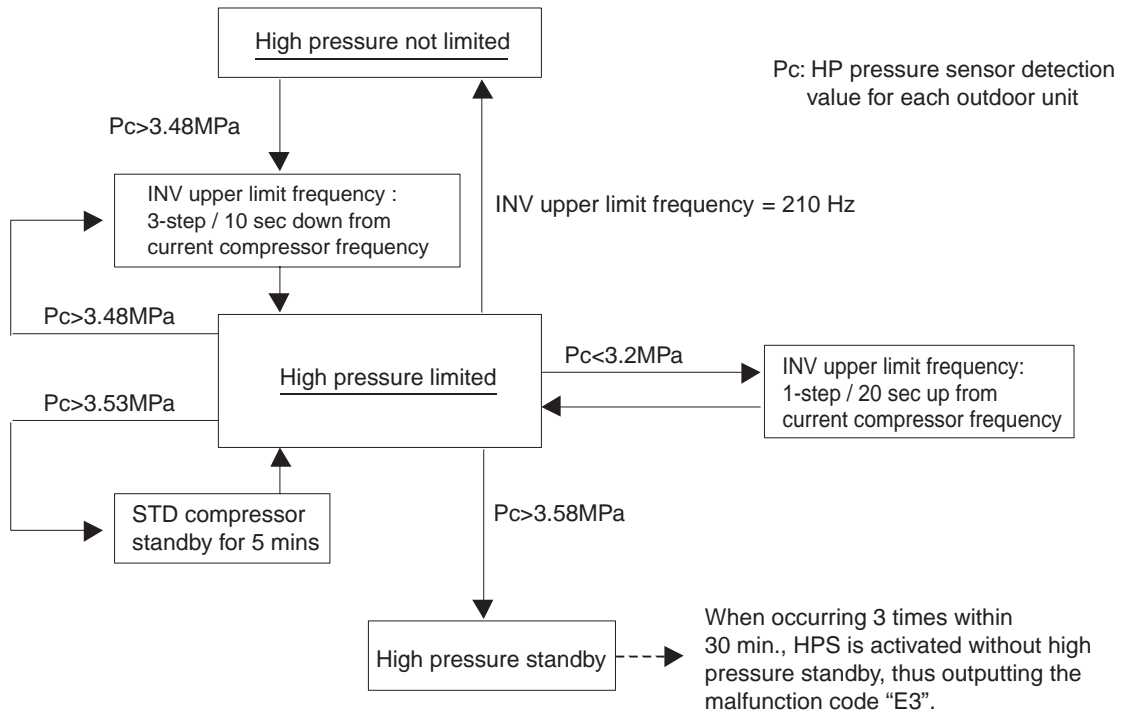

[In heating operation]

H In the case of multi-outdoor-unit system, the entire system performs this control in the following sequence.

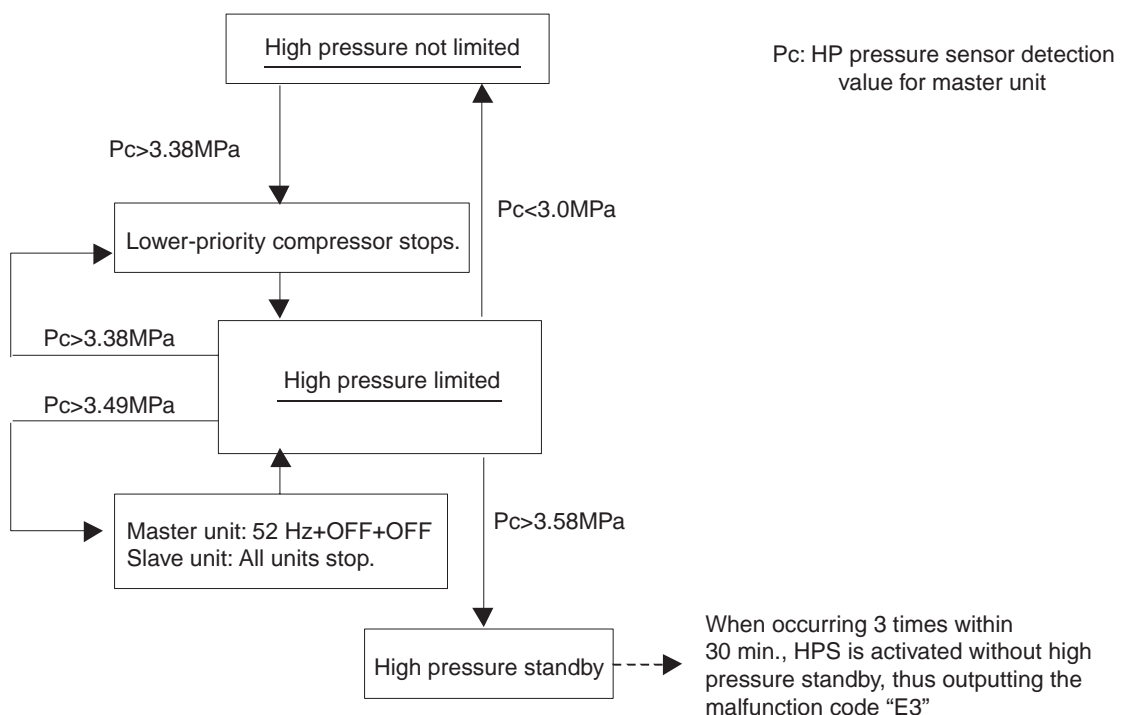

## 4.2 Low Pressure Protection Control

This low pressure protection control is used to protect compressors against the transient decrease of low pressure.

[In cooling operation]

H In the case of multi-outdoor-unit system, the entire system performs this control in the following sequence.

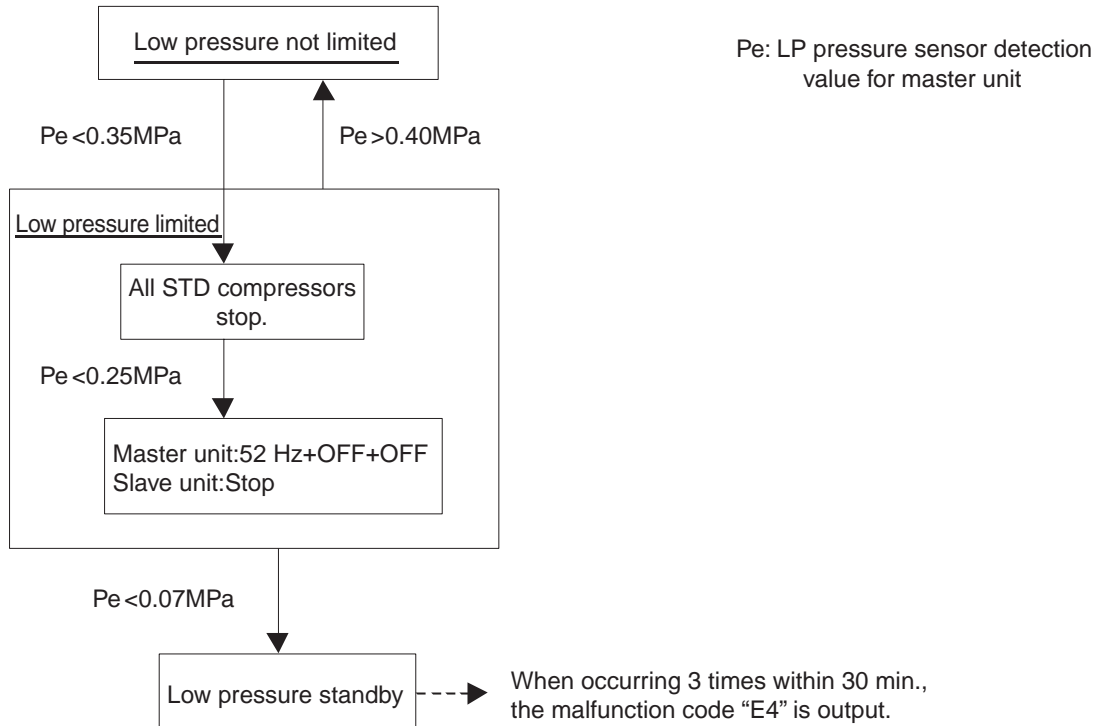

[In heating operation]

H In the case of multi-outdoor-unit system, each outdoor unit performs this control individually in the following sequence.

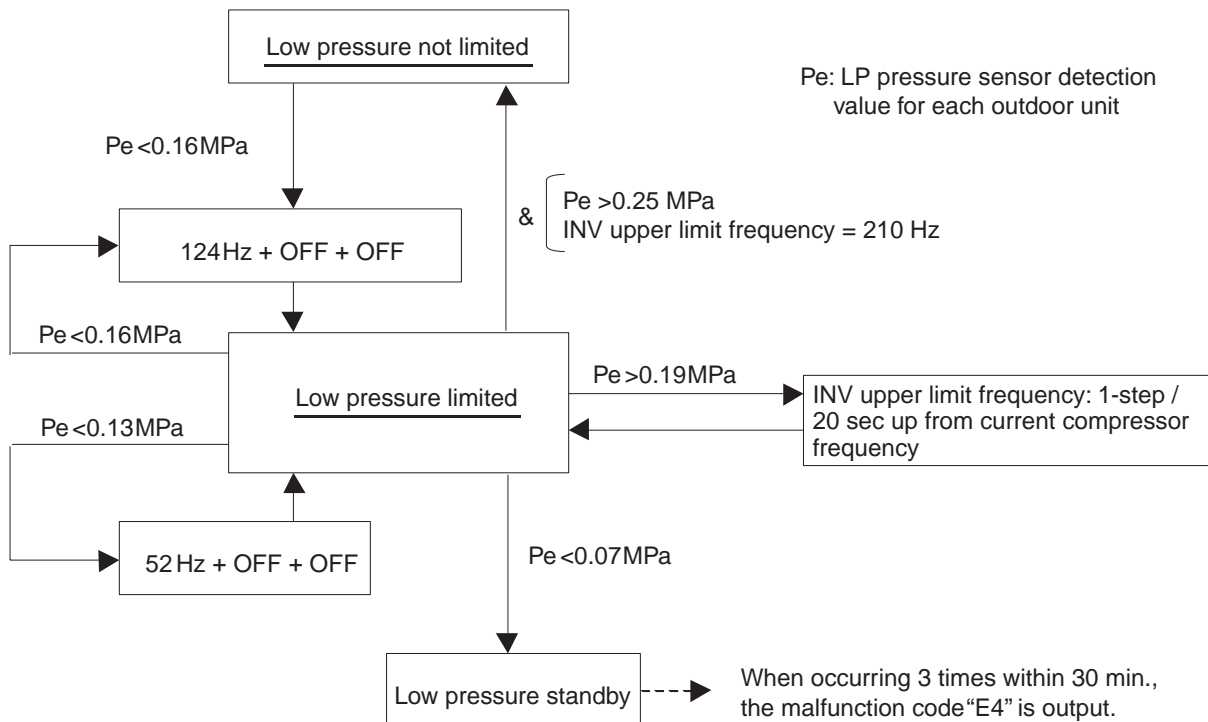

### 4.3 Discharge Pipe Protection Control

This discharge pipe protection control is used to protect the compressor internal temperature against a malfunction or transient increase of discharge pipe temperature.

H Each compressor performs the discharge pipe temperature protection control individually in the following sequence.

[INV compressor]

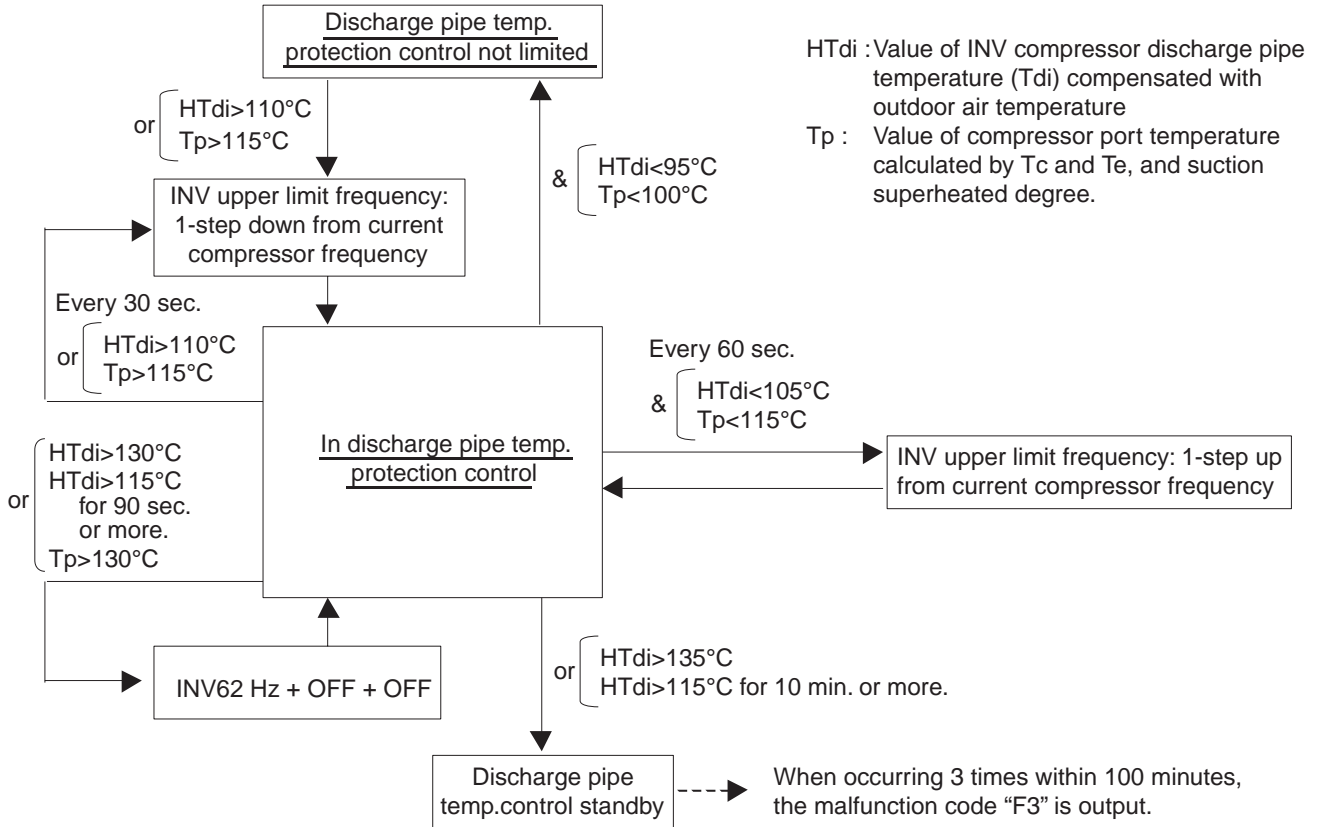

[STD compressor]

HTdi : Value of INV compressor discharge pipe temperature (Tdi) compensated with outdoor air temperature  
 Tp : Value of compressor port temperature calculated by Tc and Te, and suction superheated degree.

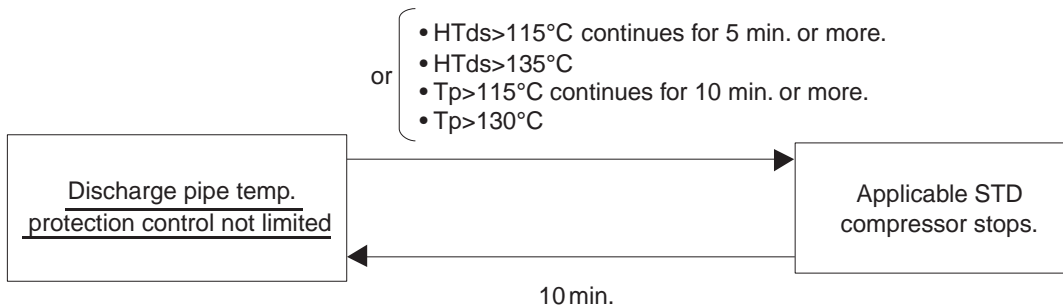

## 4.4 Inverter Protection Control

Inverter current protection control and inverter fin temperature control are performed to prevent tripping due to a malfunction, or transient inverter overcurrent, and fin temperature increase.

H In the case of multi-outdoor-unit system, each INV compressor performs these controls in the following sequence.

[Inverter overcurrent protection control]

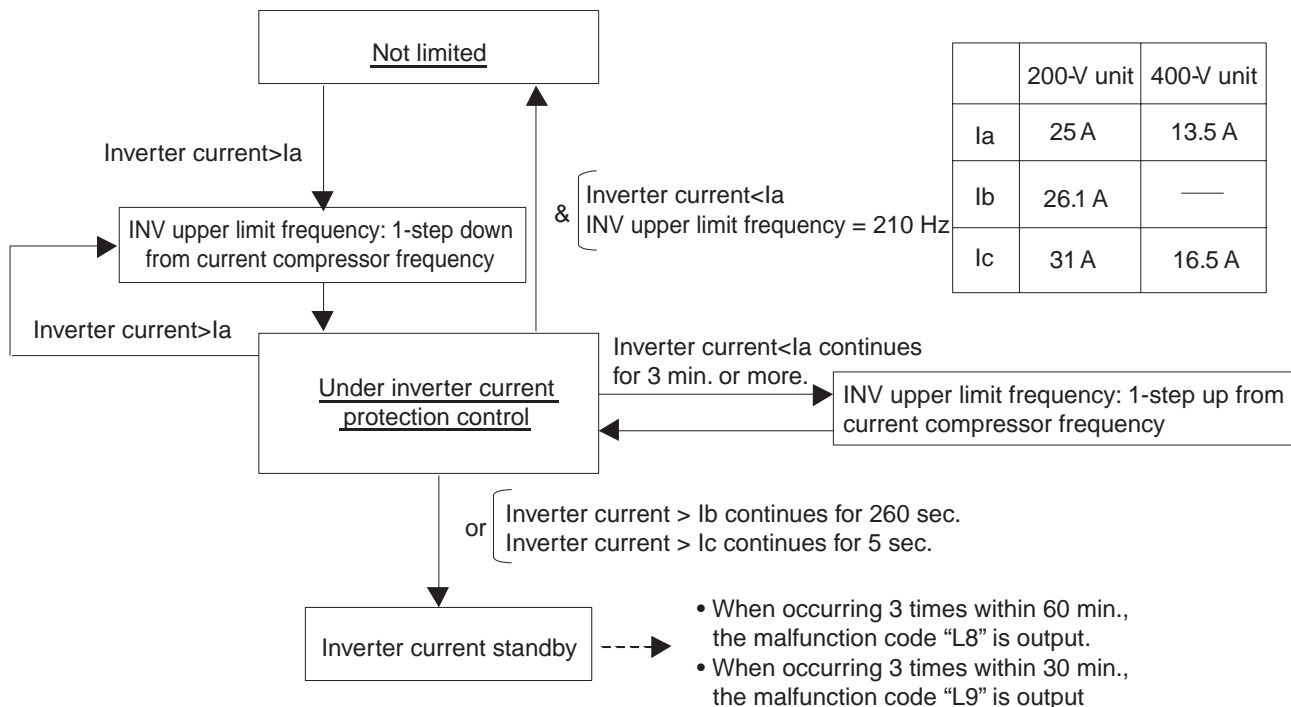

[Inverter fin temperature control]

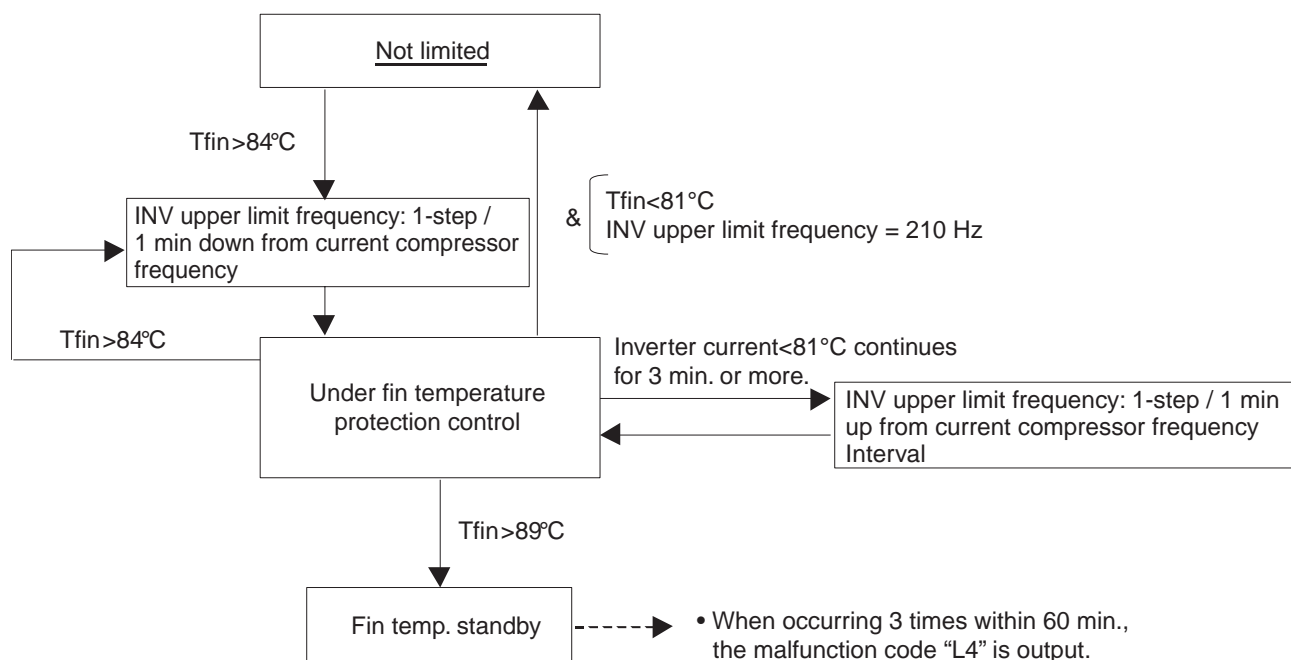

## 4.5 STD Compressor Overload Protection

This control is used to prevent abnormal heating due to overcurrent to the compressor resulting from failures of STD compressor such as locking.

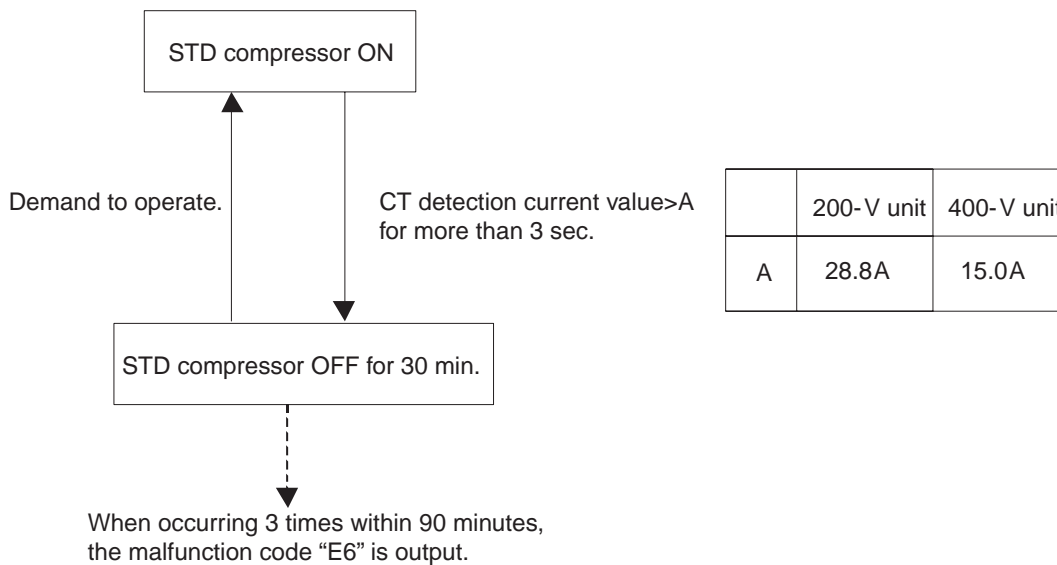

## 5. Other Control

### 5.1 Outdoor Unit Rotation

In the case of multi-outdoor-unit system, this outdoor unit rotation is used to prevent the compressor from burning out due to unbalanced oil level between outdoor units.

#### [Details of outdoor unit rotation]

In the case of multi-outdoor-unit system, each outdoor unit is given an operating priority for the control.

Outdoor unit rotation makes it possible to change the operating priority of outdoor units.

Thus, the system becomes free of compressors that stop over an extended period of time at the time of partial loading, preventing unbalanced oil level.

#### [Timing of outdoor unit rotation]

or {  
 After oil return operation  
 After defrosting operation  
 At the beginning of the starting control

Example) The following diagram shows outdoor unit rotation in combination of 3 outdoor units.

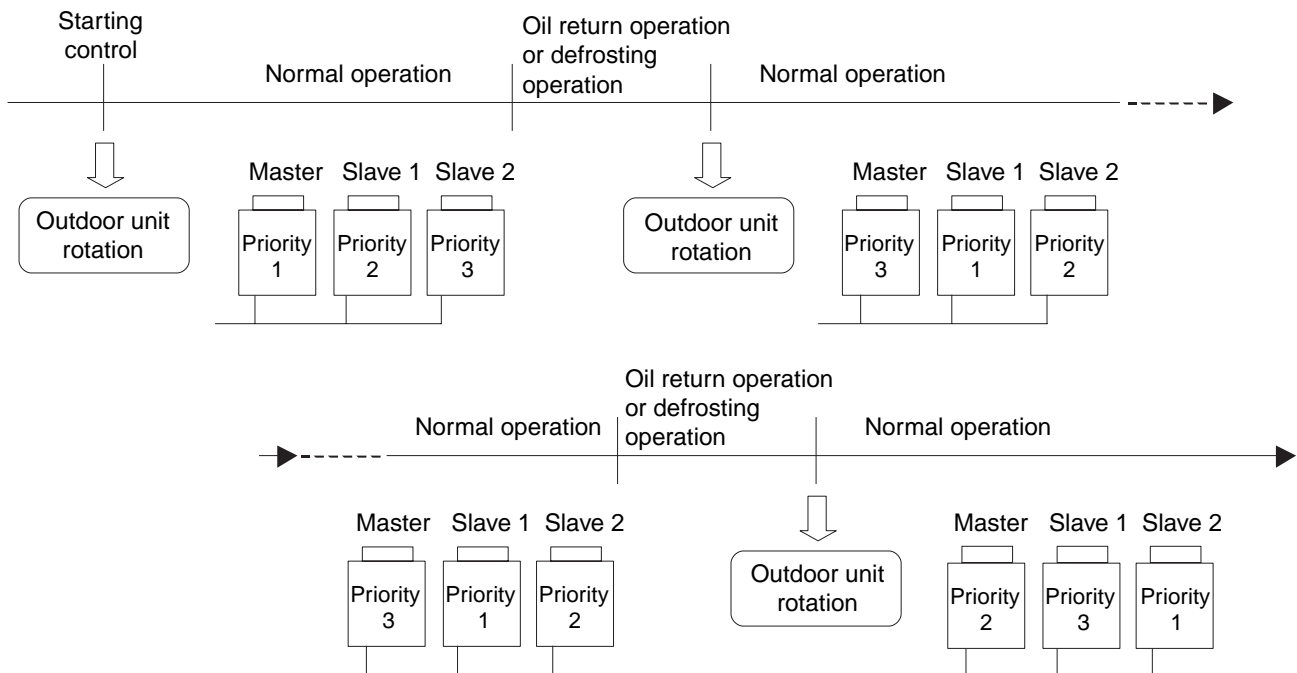

\* “Master unit”, “slave unit 1” and “slave unit 2” in this section are the names for installation. They are determined in installation work, and not changed thereafter. (These names are different from “master unit” and “slave unit” for control.)

The outdoor unit connected the control wires (F1 and F2) for the indoor unit should be designated as master unit

Consequently, The LED display on the main PCB for “master unit”, “slave unit 1” and “slave unit 2” do not change. (Refer to the page 90.)

## 5.2 Emergency Operation

If the compressor cannot operate, this control inhibits any applicable compressor or outdoor unit from operating to perform emergency operation only with the operative compressor or outdoor unit.



### Caution

**"For making a compressor unable to operate due to malfunction, etc., be sure to conduct the work with emergency operation setting.**

**Never execute work such as disconnection of the power cable from magnet contactor. (Otherwise, other normal compressors may malfunction.)**

**\* Because the units will be operated in the combination with which oil pressure equalization between compressors cannot be performed.**

### 5.2.1 Restrictions for Emergency Operation

- In the case of system with 1 outdoor unit installed, only when thermostats of indoor units having a capacity of 50% or more of the outdoor unit capacity turn ON, the emergency operation is functional. (If the total capacity of indoor units with thermostat ON is small, the outdoor unit cannot operate.)
- If the emergency operation is set while the outdoor unit is in operation, the outdoor unit stops once after pump-down residual operation (a maximum of 5 minutes elapsed).

### 5.2.2 In the Case of 1-Outdoor-Unit System (RXYQ8 to 16M)

- Emergency operation with settings in service mode
- \* "Inhibition of operation" is set with each compressor.

- To inhibit INV compressor from operating → Set setting mode 2 from No. 0 to No. 2.

(Procedure)

- (1) Press and hold the MODE button (BS1) for 5 sec. or more.
- (2) Press the RETURN button (BS3) once.
- (3) Press the SET button (BS2) one.
- (4) Press the RETURN button (BS3) twice.
- (5) Press the MODE button (BS1) once.

LED display (○:ON ●:OFF ◐:Blink)  
H1P — — H7P

○ ● ● ● ● ● ● ●

○ ● ● ● ● ● ● ◐ (Factory set)

○ ● ● ● ● ● ● ●

○ ● ● ● ● ● ● ●

● ● ○ ● ● ● ● ●

- To inhibit STD1 and STD2 compressors from operating → Set setting mode 2 from No. 19 to No. 2. (RXYQ8M to RXYQ16M)

(Procedure)

- (1) Press and hold the MODE button (BS1) for 5 sec. or more.
- (2) Press the SET button (BS2) 19 times.
- (3) Press the RETURN button (BS3) once.
- (4) Press the SET button (BS2) once.
- (5) Press the RETURN button (BS3) twice.
- (6) Press the MODE button (BS1) once.

LED display (○:ON ●:OFF ◐:Blink)  
H1P — — H7P

○ ● ● ● ● ● ● ●

○ ● ○ ● ● ○ ○ ○  
○ ● ● ● ● ● ● ◐ (Factory set)

○ ● ● ● ● ● ● ●

○ ● ● ● ● ● ● ●

● ● ○ ● ● ● ● ●

- To inhibit STD2 compressor from operating → Set setting mode 2 from No. 19 to No.3.(RXYQ14M)

(Procedure)

- (1) Press and hold the MODE button (BS1) for 5 sec. or more.
- (2) Press the SET button (BS2) 19 times.
- (3) Press the RETURN button (BS3) once.
- (4) Press the SET button (BS2) twice.
- (5) Press the RETURN button (BS3) twice.
- (6) Press the MODE button (BS1) once.

LED display (○:ON ●:OFF ◐:Blink)  
H1P — — H7P

○ ● ● ● ● ● ● ●

○ ● ○ ● ● ○ ○ ○  
○ ● ● ● ● ● ● ◐ (Factory set)

○ ● ● ● ● ● ● ●

○ ● ● ● ● ● ● ●

● ● ○ ● ● ● ● ●

- With RXYQ14M and 16M, if INV compressor is inhibited from operating, only 1 STD compressor can operate for reasons of oil equalization.
- With RXYQ14M and 16M, STD1 compressor cannot be inhibited from operating for reasons of oil equalization.
- When 1 outdoor unit is installed (with RXYQ8M to 16M), automatic backup operation cannot be performed.

### 5.2.3 In The Case of Multi-Outdoor-Unit System (RXYQ18 to 48M)

#### Automatic backup operation

With multi-outdoor-unit system, if a certain outdoor unit system malfunctions (i.e., the system stops and indoor unit remote controller displays the malfunction), by resetting the system with the indoor unit remote controller, the applicable outdoor unit is inhibited from operating for 8 hours, thus making it possible to perform emergency operation automatically.

However, in the event any of the following malfunctions occurs, automatic backup operation can be performed.

#### Malfunctions under which automatic backup operation can be performed:

- E3, E4, E5, E7
- F3
- H7, H9
- J2, J3, J5, J6, J7, J9, JA, JC
- L3, L4, L5, L8, L9, LC
- U2, UJ

#### Emergency operation with settings in service mode

\* "Inhibition of operation" is set with each outdoor unit.

Make the following settings with the master unit. (Setting with the slave unit becomes disabled.)

- \* Discriminate the operating status of the master unit/slave units through the following LED display.

- To inhibit the master unit from operating → Set setting mode 2 from No. 38 to No. 2.

#### (Procedure)

- (1) Press and hold the MODE button (BS1) for 5 sec. or more.
- (2) Press the SET button (BS2) 38 times.
- (3) Press the RETURN button (BS3) once.
- (4) Press the SET button (BS2) once.
- (5) Press the RETURN button (BS3) twice.
- (6) Press the MODE button (BS1) once.

LED display (○:ON ●:OFF ◐:Blink)  
H1P — — H7P

○ ● ● ● ● ● ● ●

○ ○ ● ● ○ ○ ● ● (Factory set)

○ ● ● ● ● ● ● ●

○ ● ● ● ● ● ● ●

● ● ○ ● ● ● ● ●

- To inhibit the slave unit 1 from operating → Set setting mode 2 from No. 39 to No. 2.

#### (Procedure)

- (1) Press and hold the MODE button (BS1) for 5 sec. or more.
- (2) Press the SET button (BS2) 39 times.
- (3) Press the RETURN button (BS3) once.
- (4) Press the SET button (BS2) once.
- (5) Press the RETURN button (BS3) twice.
- (6) Press the MODE button (BS1) once.

LED display (○:ON ●:OFF ◐:Blink)  
H1P — — H7P

○ ● ● ● ● ● ● ●

○ ○ ● ● ○ ○ ○ ○ (Factory set)

○ ● ● ● ● ● ● ●

○ ● ● ● ● ● ● ●

● ● ○ ● ● ● ● ●



- To inhibit the slave unit 2 from operating → Set setting mode 2 from No. 40 to No. 2.

LED display (○:ON ●:OFF ◐:Blink)  
H1P — — H7P

(Procedure)

- (1) Press and hold the MODE button (BS1) for 5 sec. or more.
- (2) Press the SET button (BS2) 40 times.
- (3) Press the RETURN button (BS3) once.
- (4) Press the SET button (BS2) once.
- (5) Press the RETURN button (BS3) twice.
- (6) Press the MODE button (BS1) once.

○ ● ● ● ● ● ● ●

○ ○ ● ○ ● ● ● ● (Factory set)  
○ ● ● ● ● ● ● ●  
○ ● ● ● ● ● ● ●  
○ ● ● ● ● ● ● ●  
● ● ○ ● ● ● ● ●

\*

- In the case of multi-outdoor-unit system, “Inhibition of operation” is not set with each compressor individually.
- In the case of multi-outdoor-unit system, when the above “Inhibition of operation” is set, outdoor unit rotation is not functional.



**Note :** Reset the power supply during the outdoor unit is stopping to cancel the automatic backup operation forcibly.

### 5.3 Demand Operation

In order to save the power consumption, the capacity of outdoor unit is saved with control forcibly by using “Demand 1 Setting” or “Demand 2 Setting”. To operate the unit with this mode, additional setting of “Continuous Demand Setting” or external input by external control adapter is required.

**[Demand 1 setting]**

Setting	Standard for upper limit of power consumption
Demand 1 setting 1	Approx. 60%
Demand 1 setting 2 (factory setting)	Approx. 70%
Demand 1 setting 3	Approx. 80%

**[Demand 2 setting]**

Setting	Standard for upper limit of power consumption
Demand 2 setting 2 (factory setting)	Approx. 40%

H Other protection control functions have precedence over the above operation.

### 5.4 Heating operation prohibition

Heating operation is prohibited above 24°C ambient temperature.

## 6. Outline of Control (Indoor Unit)

### 6.1 Drain Pump Control

- The drain pump is controlled by the ON/OFF buttons (4 button (1) - (4) given in the figure below).

#### 6.1.1 When the Float Switch is Tripped While the Cooling Thermostat is ON:

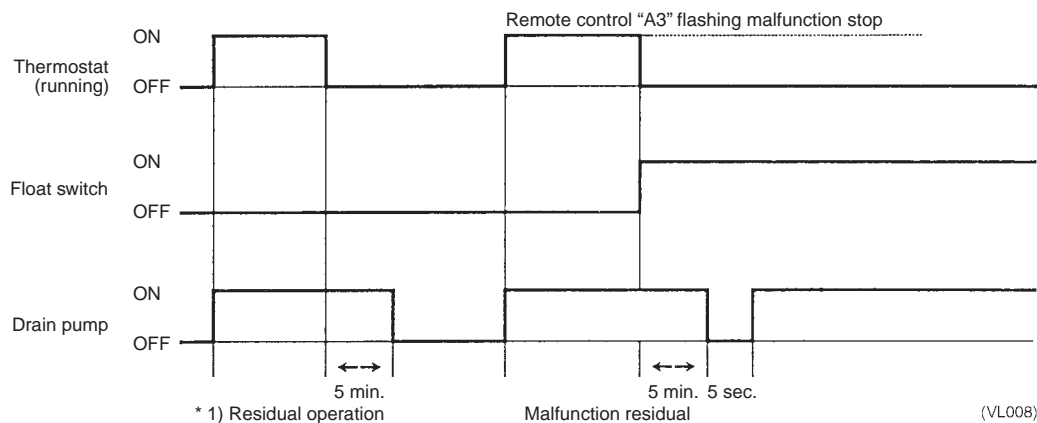

- \* 1. The objective of residual operation is to completely drain any moisture adhering to the fin of the indoor unit heat exchanger when the thermostat goes off during cooling operation.

#### 6.1.2 When the Float Switch is Tripped During Cooling OFF by Thermostat:

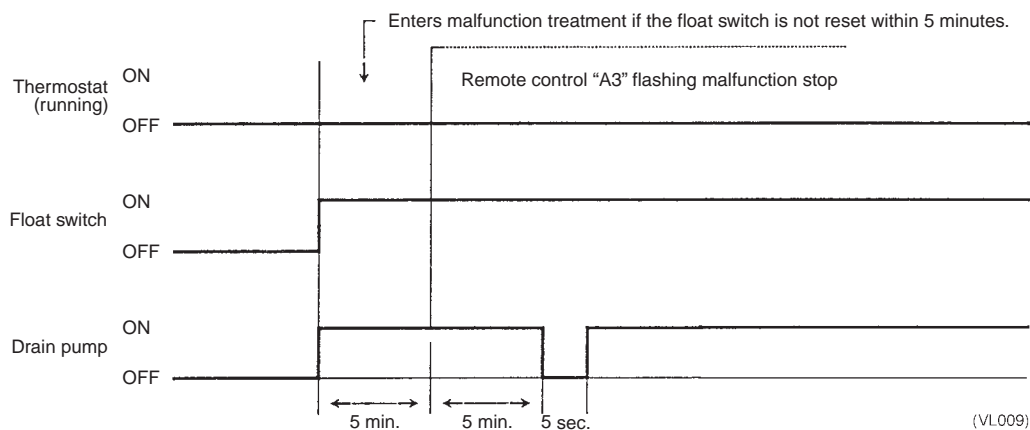

### 6.1.3 When the Float Switch is Tripped During Heating Operation:

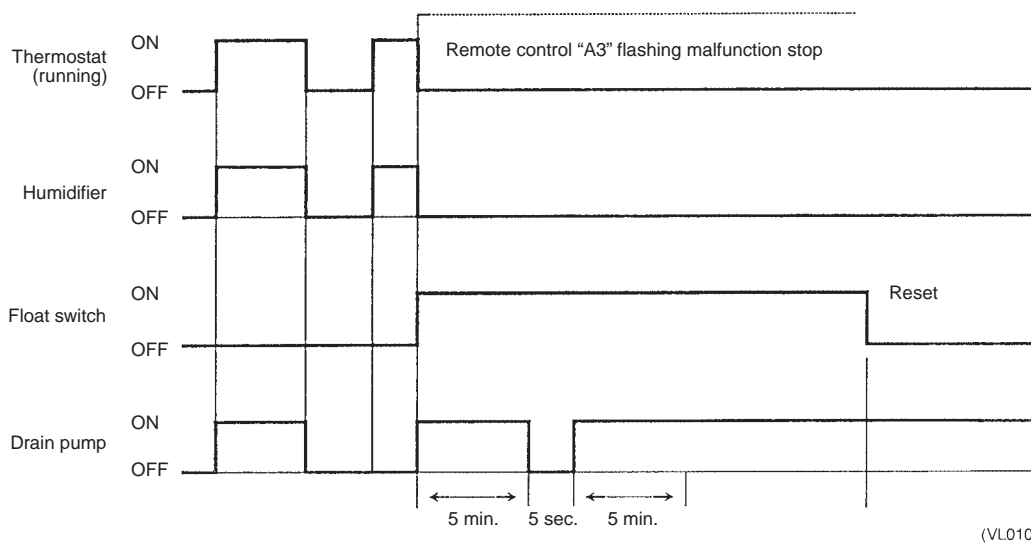

During heating operation, if the float switch is not reset even after the 5 minutes operation, 5 seconds stop, 5 minutes operation cycle ends, operation continues until the switch is reset.

### 6.1.4 When the Float Switch is Tripped and “AF” is Displayed on the Remote Controller:

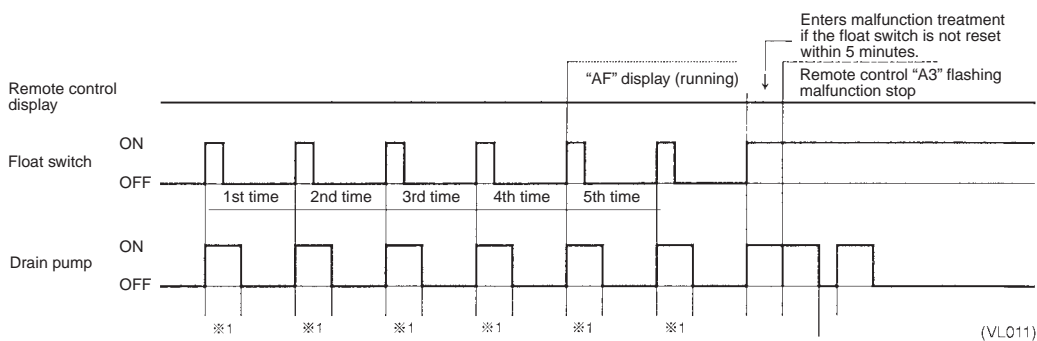

**Note:** If the float switch is tripped five times in succession, a drain malfunction is determined to have occurred. “AF” is then displayed as operation continues.

## 6.2 Louver Control for Preventing Ceiling Dirt

We have added a control feature that allows you to select the range of in which air direction can be adjusted in order to prevent the ceiling surrounding the air discharge outlet of ceiling mounted cassette type units from being soiled. (This feature is available on double flow, multi-flow and corner types.)

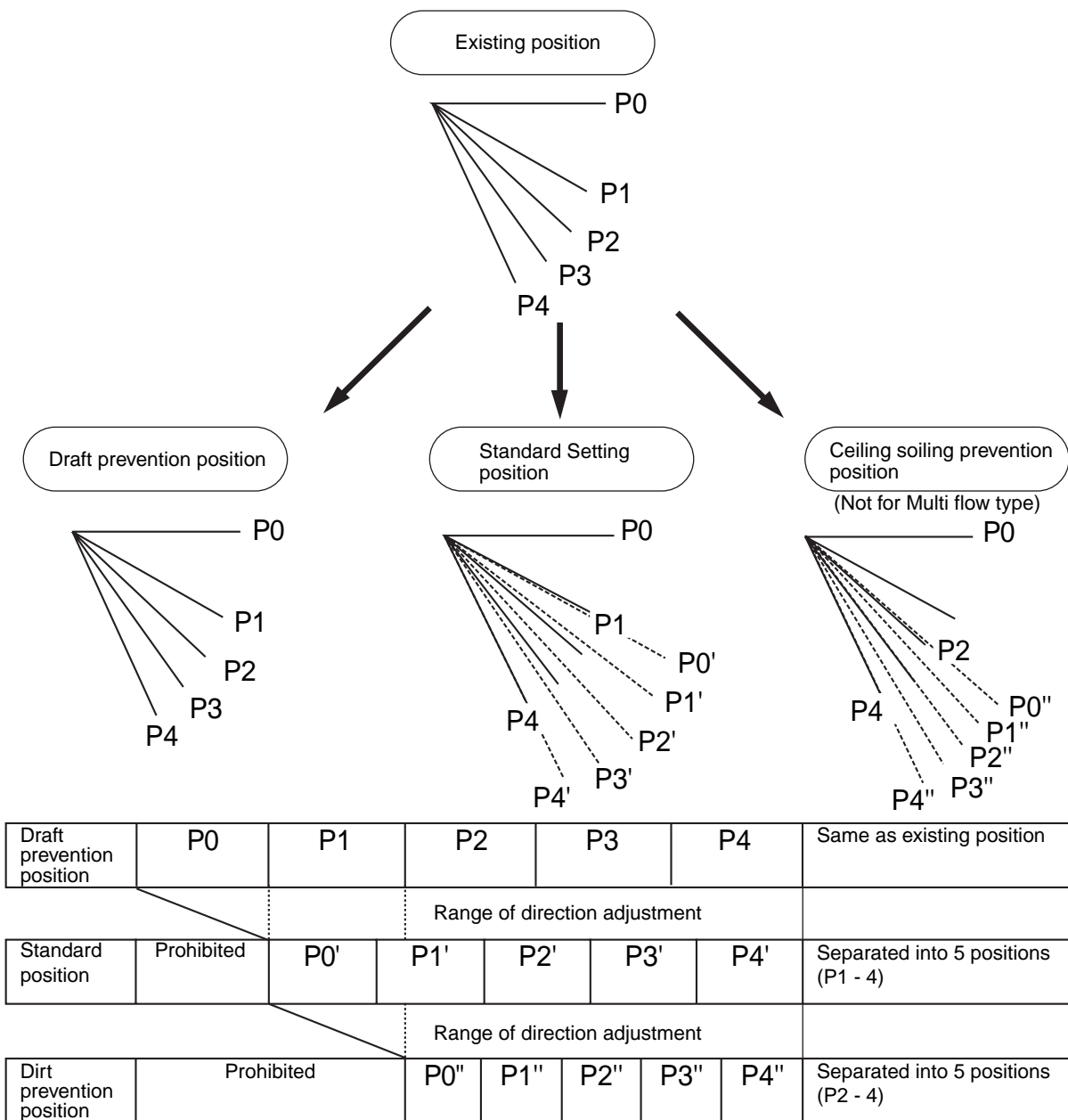

The factory set position is standard position.

(VL012)

## 6.3 Thermostat Sensor in Remote Controller

Temperature is controlled by both the thermostat sensor in remote controller and air suction thermostat in the indoor unit. (This is however limited to when the field setting for the thermostat sensor in remote controller is set to "Use.")

### Cooling

If there is a significant difference in the preset temperature and the suction temperature, fine adjustment control is carried out using a body thermostat sensor, or using the sensor in the remote controller near the position of the user when the suction temperature is near the preset temperature.

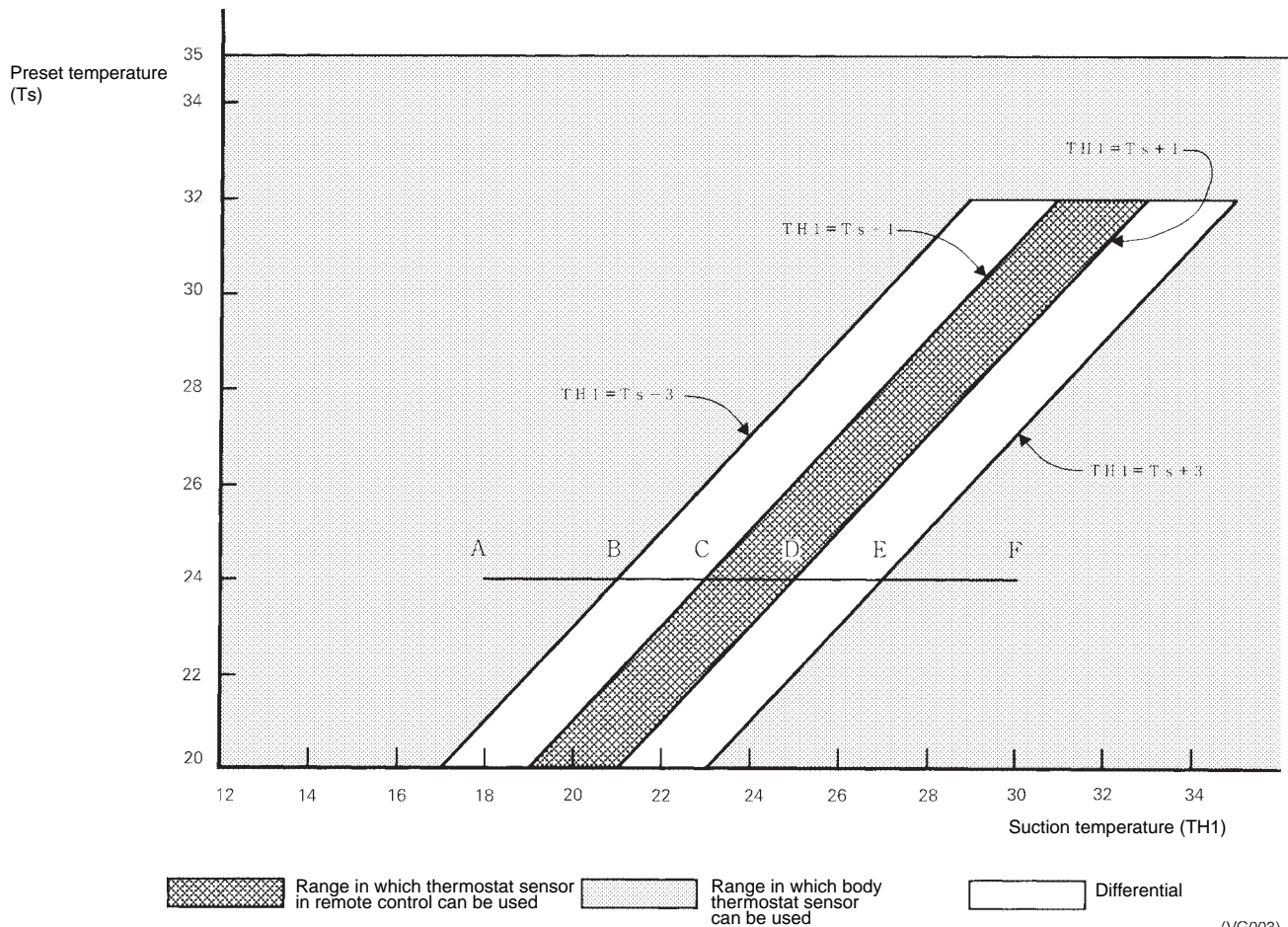

#### ■ Ex: When cooling

**Assuming the preset temperature in the figure above is 24°C, and the suction temperature has changed from 18°C to 30°C (A → F):**

(This example also assumes there are several other air conditioners, the VRV system is off, and that temperature changes even when the thermostat sensor is off.)

Body thermostat sensor is used for temperatures from 18°C to 23°C (A → C).

Remote controller thermostat sensor is used for temperatures from 23°C to 27°C (C → E).

Body thermostat sensor is used for temperatures from 27°C to 30°C (E → F).

**And, assuming suction temperature has changed from 30°C to 18°C (F → A):**

Body thermostat sensor is used for temperatures from 30°C to 25°C (F → D).

Remote controller thermostat sensor is used for temperatures from 25°C to 21°C (D → B).

Body thermostat sensor is used for temperatures from 21°C to 18°C (B → A).

## Heating

When heating, the hot air rises to the top of the room, resulting in the temperature being lower near the floor where the occupants are. When controlling by body thermostat sensor only, the unit may therefore be turned off by the thermostat before the lower part of the room reaches the preset temperature. The temperature can be controlled so the lower part of the room where the occupants are doesn't become cold by widening the range in which thermostat sensor in remote controller can be used so that suction temperature is higher than the preset temperature.

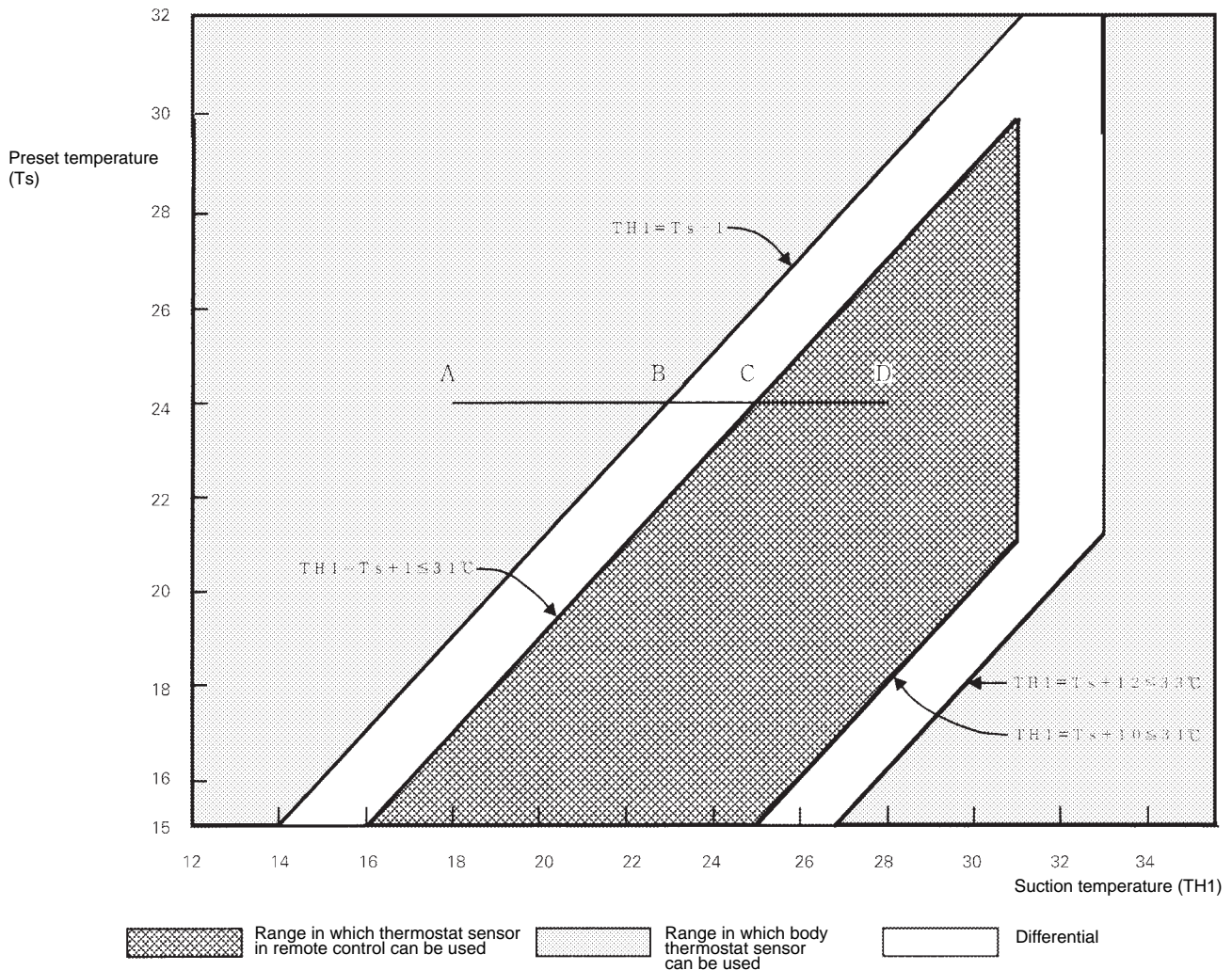

(V2769)

### ■ Ex: When heating

Assuming the preset temperature in the figure above is 24°C, and the suction temperature has changed from 18°C to 28°C (A → D):

(This example also assumes there are several other air conditioners, the VRV system is off, and that temperature changes even when the thermostat sensor is off.)

Body thermostat sensor is used for temperatures from 18°C to 25°C (A → C).

Remote controller thermostat sensor is used for temperatures from 25°C to 28°C (C → D).

And, assuming suction temperature has changed from 28°C to 18°C (D → A):

Remote controller thermostat sensor is used for temperatures from 28°C to 23°C (D → B).

Body thermostat sensor is used for temperatures from 23°C to 18°C (B → A).

## 6.4 Freeze Prevention

### Freeze Prevention by Off Cycle (Indoor Unit)

When the temperature detected by liquid pipe temperature thermistor (R2T) of the indoor unit heat exchanger drops too low, the unit enters freeze prevention operation in accordance with the following conditions, and is also set in accordance with the conditions given below.

Conditions for starting freeze prevention: Temperature is  $-1^{\circ}\text{C}$  or less for total of 40 min., or temperature is  $-5^{\circ}\text{C}$  or less for total of 10 min.

Conditions for stopping freeze prevention: Temperature is  $+7^{\circ}\text{C}$  or more for 10 min. continuously

Ex: Case where temperature is  $-5^{\circ}\text{C}$  or less for total of 10 min.

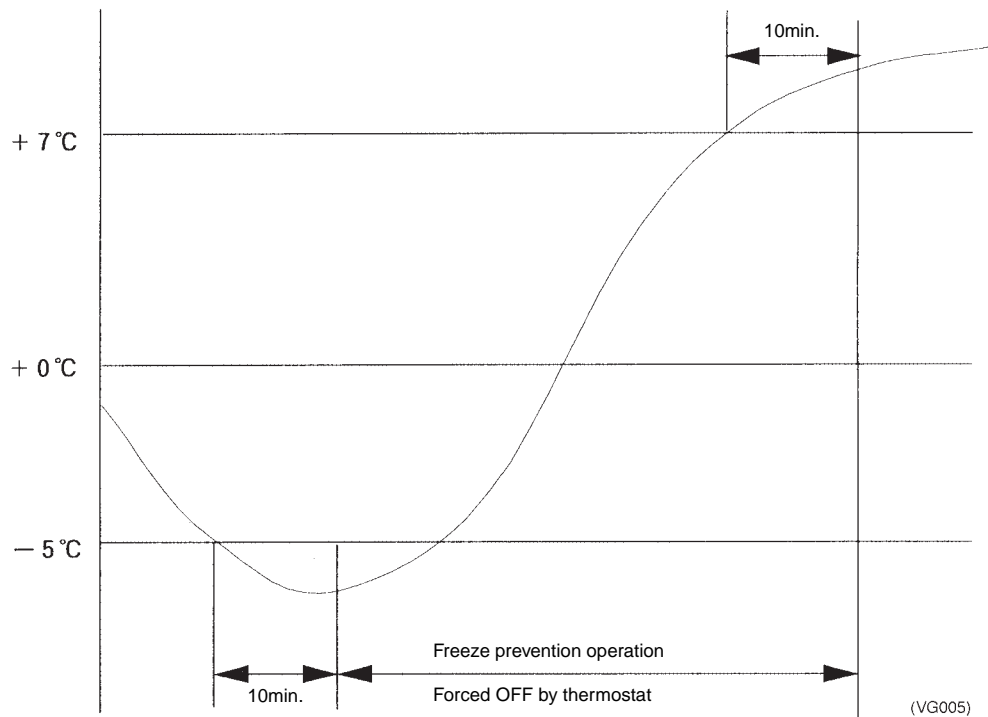

## 6.5 Control of outdoor air Processing unit (Unique Control for Outdoor Air Processing Unit)

### 6.5.1 Selection of Operation Mode (by suction air thermostat)

**Objective** To select cooling, heating, or fan operation mode according to the suction air (outdoor air) temperature.

**Details** [Outdoor air processing unit]

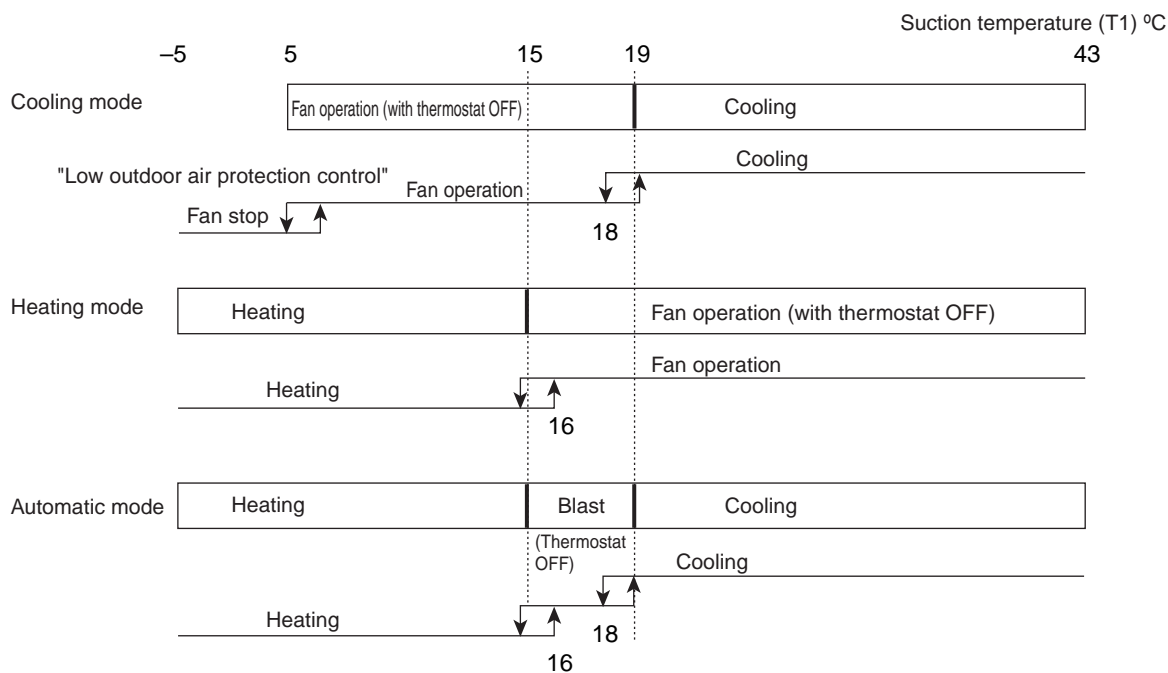



### 6.5.2 Discharge air temperature control

Used to control the EV (electronic expansion valve) opening and thermostat ON/OFF so as to keep the discharge air temperature at the set temperature.

(1) Cooling operations

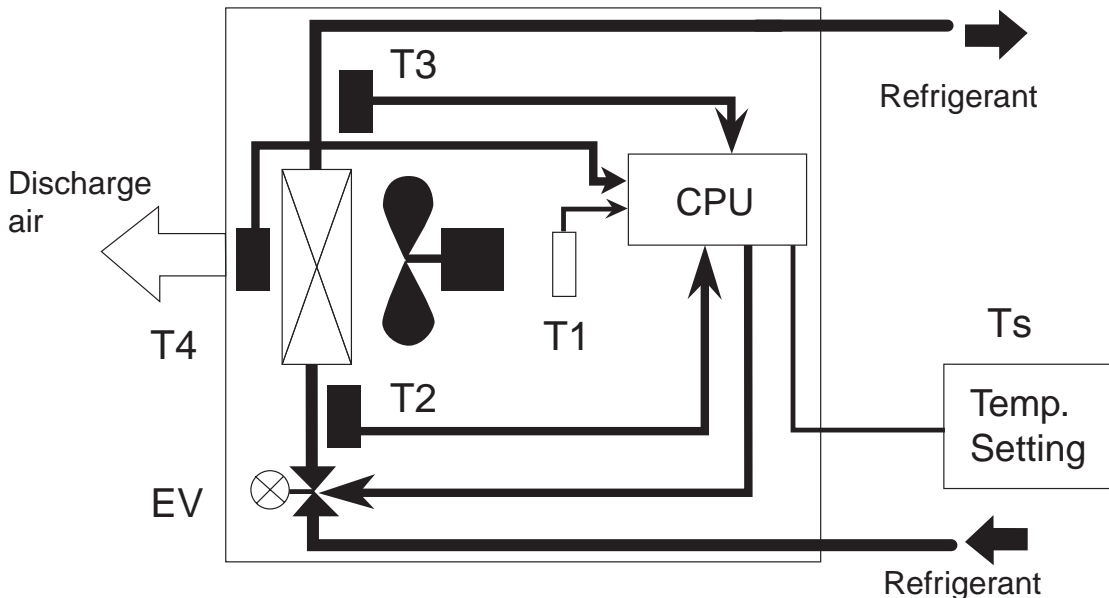

- T1: Temperature detected by suction air thermistor Th1
- T2: Temperature detected by liquid pipe temp. thermistor Th2
- T3: Temperature detected by gas pipe temp. thermistor Th3
- T4: Temperature detected by discharge air thermistor Th4
- EV: Electronic expansion valve opening

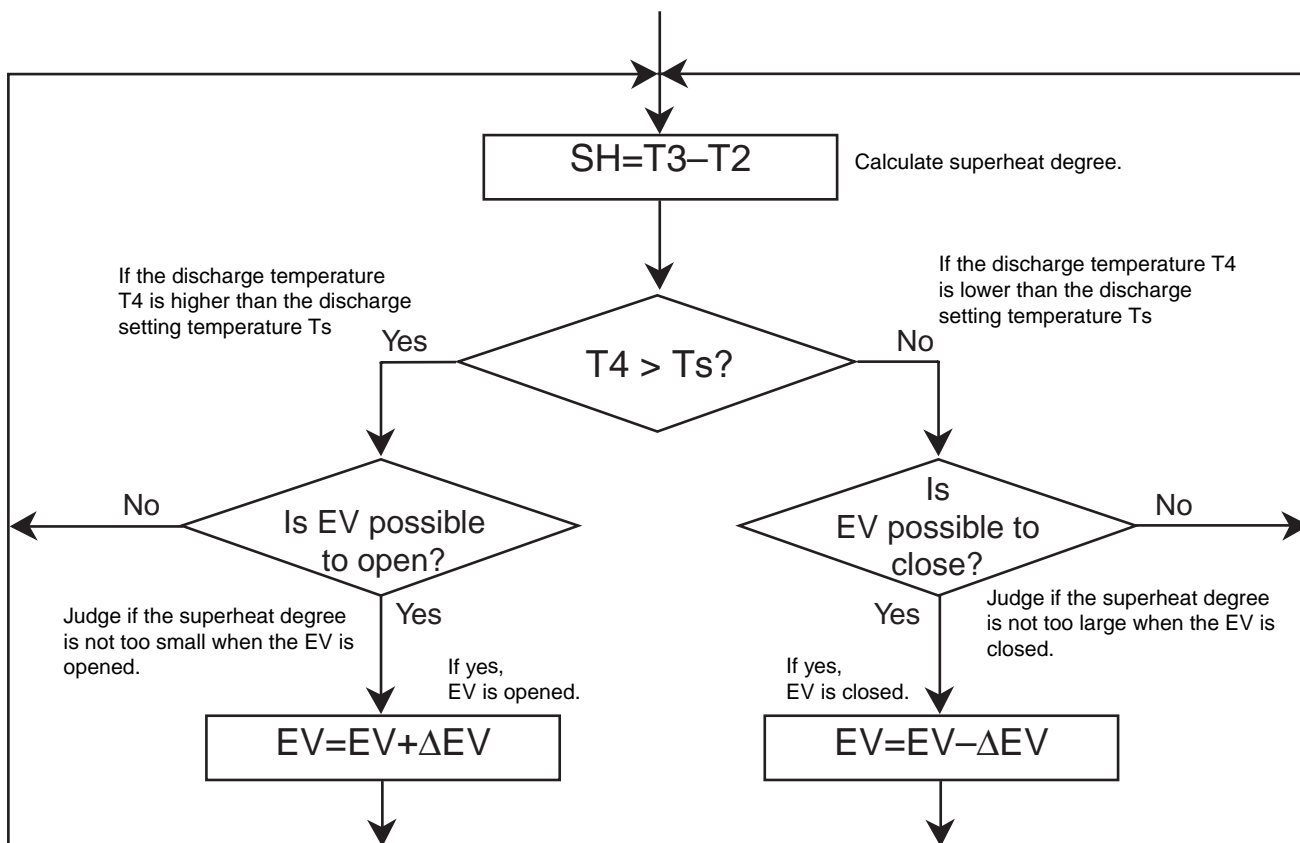

(2) Heating operations

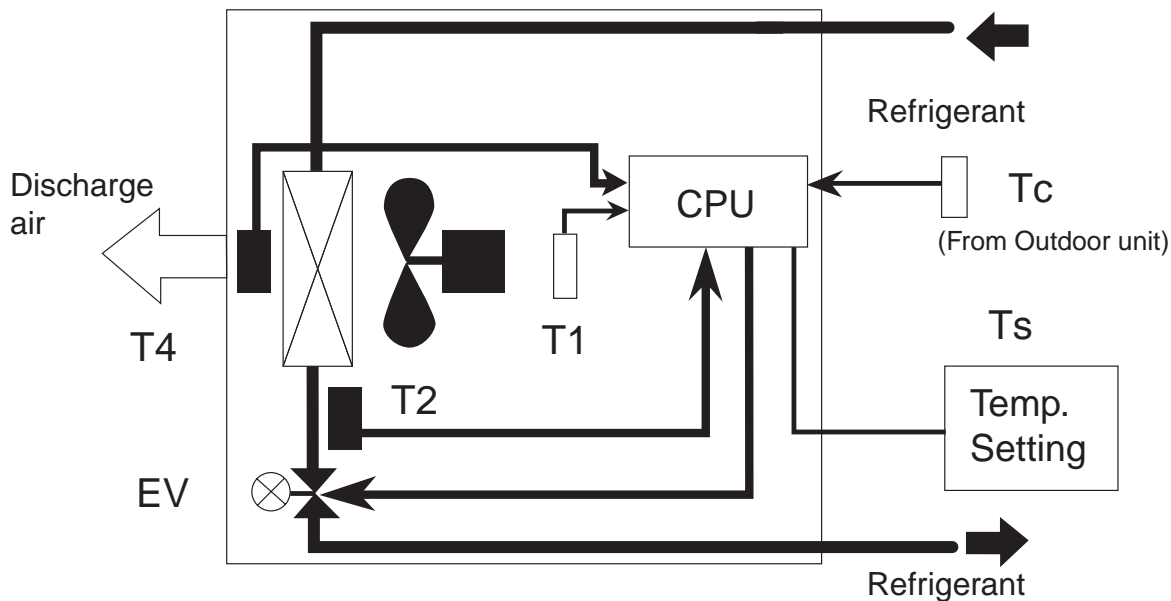

- T1: Temperature detected by suction air thermistor Th1
- T2: Temperature detected by liquid pipe temp. thermistor Th2
- T3: Temperature detected by gas pipe temp. thermistor Th3
- T4: Temperature detected by discharge air thermistor Th4
- Tc : Outdoor unit condensing temperature
- EV: Electronic expansion valve opening

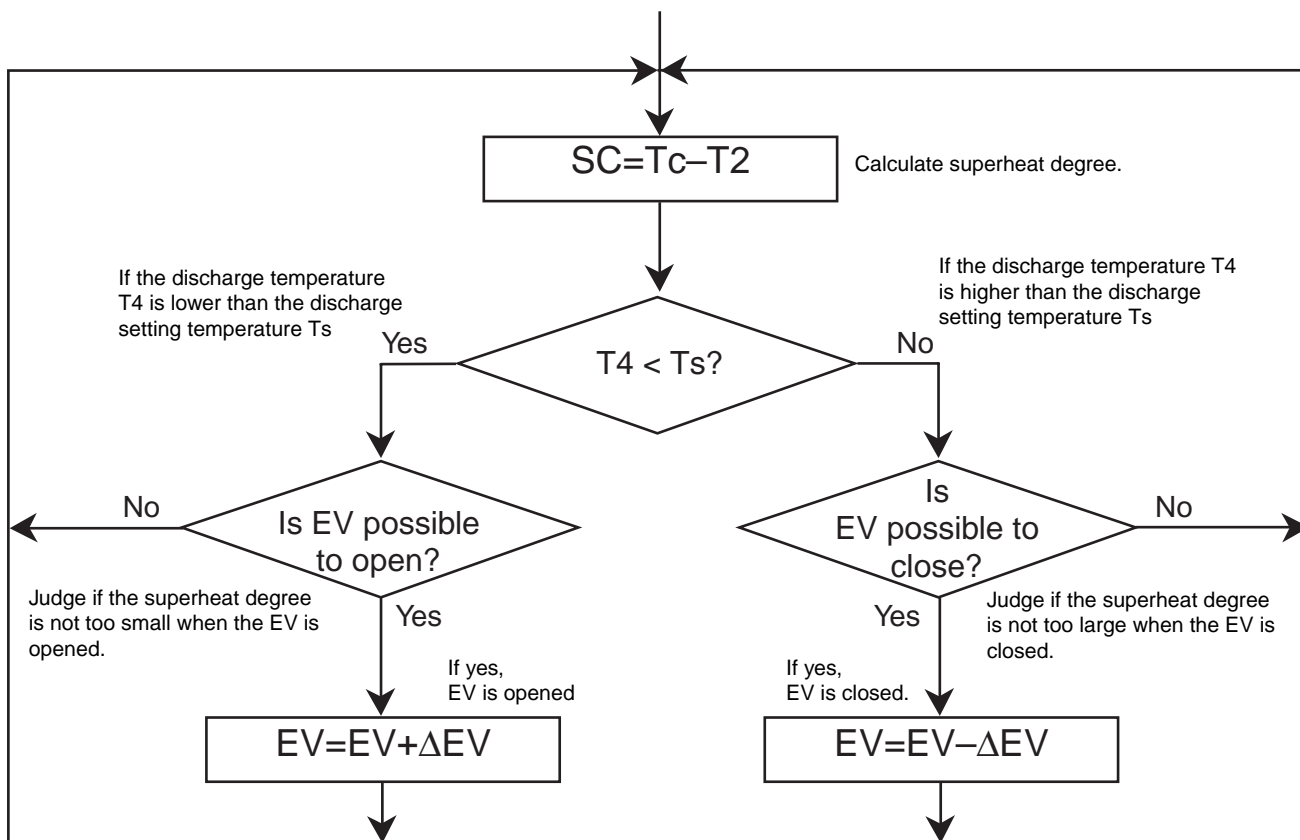

**(3) Thermostat OFF by discharge air temperature****<Cooling>**

Target discharge air temp.  $T_s$  – Discharge air temp.  $T_4$   
 $>5$  degree continue for 5 minutes.  
 →Thermostat stops for 1 minute.

**<Heating>**

Discharge air temp.  $T_4$  – Target discharge air temp.  $T_s >5$  degree  
 & { EV opening is low limit } continue for 5 minutes  
 →Thermostat stops for 1 minute.

**6.5.3 Low Outdoor Air Temperature Protection Control****Objective**

In cooling (or fan operation) or heating, if outdoor air is low in temperature, stop the fan forcibly.

**Details****[Cooling and fan operation]**

Turn OFF the fan for a period of 60 minutes at a suction temperature of 5 °C or lower.

In order to monitor the outdoor air temperature, however, turn ON the fan for a period of one minute and turn OFF the fan again at a temperature of 5 °C or lower after the said timer completes the operative period.

Reset the 60-minute timer when the fan stops running.

**[Heating]**

Turn OFF the fan for a period of 60 minutes at a suction temperature of –5 °C or lower.

In order to monitor the outdoor air temperature, however, turn ON the fan for a period of one minute and turn OFF the fan again at a temperature of –5 °C or lower after the said timer completes the operative period.

Reset the 60-minute timer when the fan stops running.

\* The thermostat will not turn ON in one minute due to the temperature while the fan stops.

- This control shall be disabled at test run both in cooling and heating. (The test run shall be conducted first.)

# Part 5

## Test Operation

1. Test Operation .....	114
1.1 Procedure and Outline .....	114
1.2 Operation When Power is Turned On .....	117
2. Outdoor Unit PC Board Layout .....	118
3. Field Setting .....	119
3.1 Field Setting from Remote Controller .....	119
3.2 Field Setting from Outdoor Unit.....	132

# 1. Test Operation

## 1.1 Procedure and Outline

Follow the following procedure to conduct the initial test operation after installation.

### 1.1.1 Check work prior to turn power supply on

Check the below items.

- Power wiring
- Control transmission wiring between units
- Earth wire



Check on refrigerant piping



Check on amount of refrigerant charge

- Is the wiring performed as specified?
- Are the designated wires used?
- Is the grounding work completed?
  - Use a 500V megger tester to measure the insulation.
    - Do not use a megger tester for other circuits than 200V (or 240v) circuit.
- Are the setscrews of wiring not loose?
- Is pipe size proper? (The design pressure of this product is 3.8MPa.)
- Are pipe insulation materials installed securely?
 

Liquid and gas pipes need to be insulated. (Otherwise causes water leak.)
- Are respective stop valves on liquid, gas and oil equalizing lines securely open?
- Is refrigerant charged up to the specified amount?
 

If insufficient, charge the refrigerant from the service port of stop valve on the liquid side with outdoor unit in stop mode after turning power on.
- Has the amount of refrigerant charge been recorded on “Record Chart of Additional Refrigerant Charge Amount”? (V3055)

### 1.1.2 Turn power on

Turn outdoor unit power on.



Carry out field setting on outdoor PC board



Turn indoor unit power on.

- Be sure to turn the power on 6 hours before starting operation to protect compressors. (to power on crankcase heater)
- For field settings, refer to “Field Settings” on and after P119. After the completion of field settings, set to “Setting mode 1”.

(V3056)

### 1.1.3 Check Operation

- \* During check operation, mount front panel to avoid the misjudging.
- \* Check operation is mandatory for normal unit operation.  
(When the check operation is not executed, alarm code "U3" will be displayed.)

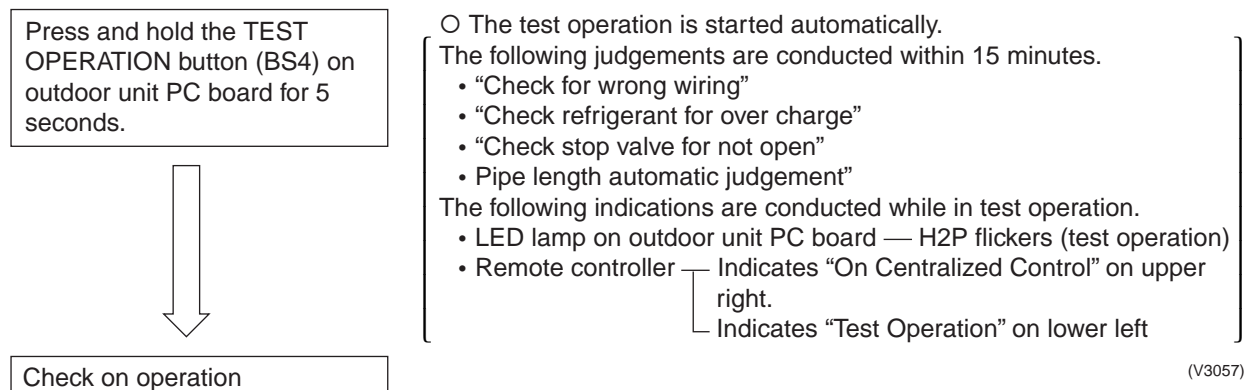

Check on operation

On completion of test operation, LED on outdoor unit PC board displays the following.  
 H3P ON: Normal completion  
 H2P and H3P ON: Abnormal completion → Check the indoor unit remote controller for abnormal display and correct it.

In the case of multi-outdoor-unit system, make setting on the master unit PC board. (Setting with the slave unit is disabled.)  
 [LED display in the case of multi-outdoor-unit system] (Same as that in emergency operation)

- \* Discriminate the operating status of the master unit/slave units through the following LED display.

LED display (○:ON ●:OFF ◐:Blink)  
 H1P — — — H7P H8P

Master: ● ● ● ○ ● ● ● ● ○  
 Slave 1: ● ● ● ● ● ● ● ● ◐  
 Slave 2: ● ● ● ● ● ● ● ● ●  
 (Factory set)

#### Malfunction code

In case of an alarm code displayed on remote controller:

Cause of trouble due to faulty installation work	Alarm code	Countermeasure
Closed stop valve of outdoor unit	E3	In case of RXYQ5 to 16M (Single outdoor installation) Liquid side stop valve : Open Gas side stop valve : Open Oil equalizing pipe stop valve : Close In case of RXYQ18 to 48M (Multi outdoor installation) Liquid side stop valve : Open Gas side stop valve : Open Oil equalizing pipe stop valve : Open
	E4	
	F3	
	UF	
Reversed phase in power cable connection for outdoor unit	U1	Change connection of two wires among three for correct phasing.
Electric power for outdoor or indoor unit is not supplied. (Including open phase)	U4	Check that the power cable for outdoor unit is connected properly.
Incorrect wiring between units	UF	Check that the wiring between units corresponds correctly to refrigerant piping system.
Refrigerant overcharge	E3 F6 UF	Compute again optimum amount of refrigerant to be added based on the piping length, then, collect the excessive amount by using refrigerant collector to make the refrigerant amount proper.
Insufficient refrigerant	E4 F3	- Check that additional charging has been carried out. - Compute again the refrigerant amount to be added based on the piping length, and charge proper amount of refrigerant additionally.

### 1.1.4 Confirmation on normal operation

- Conduct normal unit operation after the check operation has been completed.  
(When outdoor air temperature is 24°C or higher, the unit can not be operated with heating mode. See the instruction manual attached.)  
Confirm that the indoor/outdoor units can be operated normally.  
(When an abnormal noise due to liquid compression by the compressor can be heard, stop the unit immediately, and turn on the crankcase heater to heat up it sufficiently, then start operation again.)
- Operate indoor unit one by one to check that the corresponding outdoor unit operates.
- Confirm that the indoor unit discharges cold air (or warm air).
- Operate the air direction control button and flow rate control button to check the function of the devices.

## 1.2 Operation When Power is Turned On

### 1.2.1 When Turning On Power First Time

The unit cannot be run for up to 12 minutes to automatically set the master power and address (indoor-outdoor address, etc.).

#### Status

Outdoor unit

Test lamp H2P .... Blinks

Can also be set during operation described above.

Indoor unit

If ON button is pushed during operation described above, the "UH" malfunction indicator blinks. (Returns to normal when automatic setting is complete.)

### 1.2.2 When Turning On Power The Second Time and Subsequent

Tap the RESET button on the outdoor unit PC board. Operation becomes possible for about 2 minutes. If you do not push the RESET button, the unit cannot be run for up to 10 minutes to automatically set master power.

#### Status

Outdoor unit

Test lamp H2P .... Blinks

Can also be set during operation described above.

Indoor unit

If ON button is pushed during operation described above, the operation lamp lights but the compressor does not operate. (Returns to normal when automatic setting is complete.)

### 1.2.3 When an Indoor Unit or Outdoor unit Has Been Added, or Indoor or Outdoor Unit PC Board Has Been Changed

Be sure to push and hold the RESET button for 5 seconds. If not, the addition cannot be recognized. In this case, the unit cannot be run for up to 12 minutes to automatically set the address (indoor-outdoor address, etc.)

#### Status

Outdoor unit

Test lamp H2P .... ON

Can also be set during operation described above.

Indoor unit

If ON button is pushed during operation described above, the "UH" or "U4" malfunction indicator blinks. (Returns to normal when automatic setting is complete.)



**Caution** When the 400 volt power supply is applied to "N" phase by mistake, replace Inverter P.C.B (A2P) and control transformer (T1R, T2R) in switch box together.

(V0847)



## 2. Outdoor Unit PC Board Layout

### Outdoor unit PC board

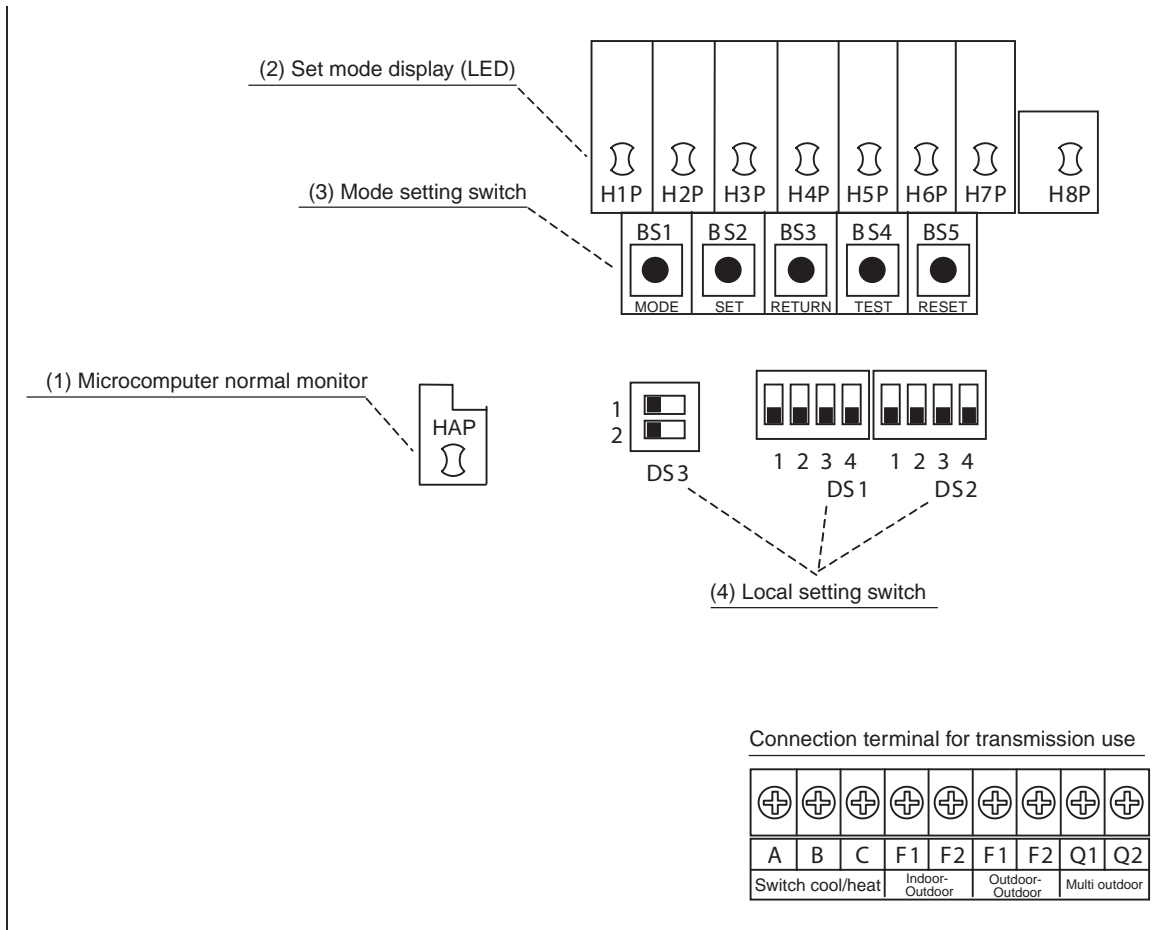

(V3054)

- (1) Microcomputer normal monitor  
This monitor blinks while in normal operation, and turns on or off when a malfunction occurs.
- (2) Set mode display (LED)  
LEDs display mode according to the setting.
- (3) Mode setting switch  
Used to change mode.
- (4) Local setting switch  
Used to make local settings.

## 3. Field Setting

### 3.1 Field Setting from Remote Controller





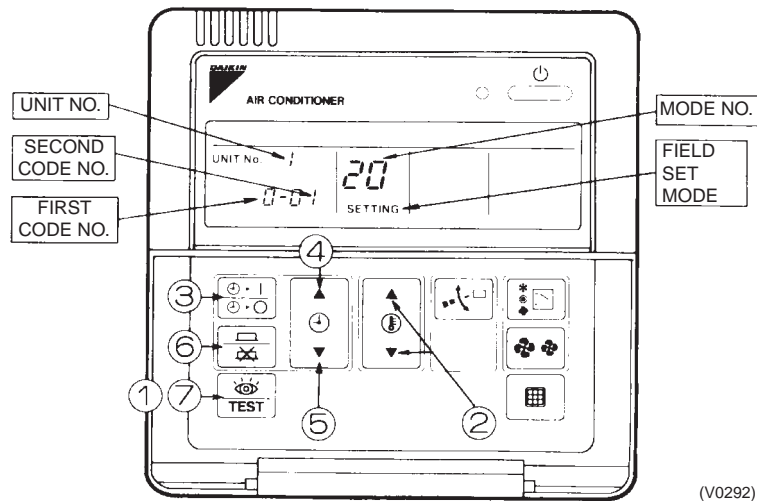

Individual function of indoor unit can be changed from the remote controller. At the time of installation or after service inspection / repair, make the local setting in accordance with the following description.

Wrong setting may cause malfunction.

(When optional accessory is mounted on the indoor unit, setting for the indoor unit may be required to change. Refer to information in the option handbook.)

#### 3.1.1 Wired Remote Controller <BRC1A61, 62>



1. When in the normal mode, press the “” button for a minimum of four seconds, and the FIELD SET MODE is entered.
2. Select the desired MODE NO. with the “” button (2).
3. During group control, when setting by each indoor unit (mode No. 20, 22 and 23 have been selected), push the “” button (3) and select the INDOOR UNIT NO to be set. (This operation is unnecessary when setting by group.)
4. Push the “” upper button (4) and select FIRST CODE NO.
5. Push the “” lower button (5) and select the SECOND CODE NO.
6. Push the “” button (6) once and the present settings are SET.
7. Push the “” button (7) to return to the NORMAL MODE.

(Example)





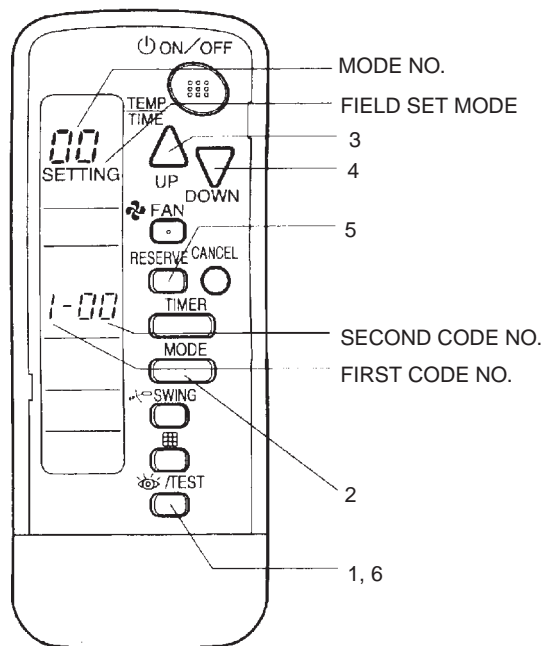

If during group setting and the time to clean air filter is set to FILTER CONTAMINATION, HEAVY, SET MODE NO. to “10” FIRST CODE NO. to “0”, and SECOND CODE NO. to “02”.

### 3.1.2 Wireless Remote Controller - Indoor Unit

BRC7C type



(V2770)

1. When in the normal mode, push the  button for 4 seconds or more, and operation then enters the "field set mode."
2. Select the desired "mode No." with the  button.
3. Pushing the  button, select the first code No.
4. Pushing the  button, select the second code No.
5. Push the timer  button and check the settings.
6. Push the  button to return to the normal mode.

(Example)

When setting the filter sign time to "Filter Dirtiness-High" in all group unit setting, set the Mode No. to "10", Mode setting No. to "0" and setting position No. to "02".

### 3.1.3 Simplified Remote Controller

BRC2A51

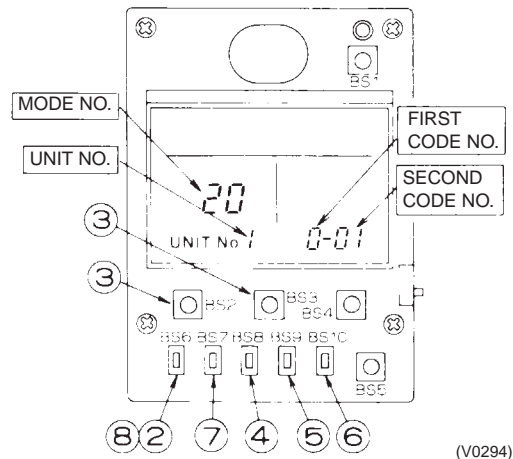

1. Remove the upper part of remote controller.
2. When in the normal mode, press the [BS6] BUTTON (②) (field set), and the FIELD SET MODE is entered.
3. Select the desired MODE No. with the [BS2] BUTTON (③) (temperature setting s) and the [BS3] BUTTON (③) (temperature setting t).
4. During group control, when setting by each indoor unit (mode No. 20, 22, and 23 have been selected), push the [BS8] (④) BUTTON (unit No.) and select the INDOOR UNIT NO. to be set. (This operation is unnecessary when setting by group.)
5. Push the [BS9] BUTTON (⑤) (set A) and select FIRST CODE NO.
6. Push the [BS10] BUTTON (⑥) (set B) and select SECOND CODE NO.
7. Push the [BS7] BUTTON (⑦) (set/cancel) once and the present settings are SET.
8. Push the [BS6] BUTTON (⑧) (field set) to return to the NORMAL MODE.
9. (Example) If during group setting and the time to clean air filter is set to FILTER CONTAMINATION - HEAVY, SET MODE NO. to "10", FIRST CODE NO. to "0", and SECOND CODE NO. to "02".

### 3.1.4 Setting Contents and Code No. – VRV Indoor unit

VRV system indoor unit settings	Mode No. Note 2	Setting Switch No.	Setting Contents	Second Code No.(Note 3)								
				01		02		03		04		
10(20)	0		Filter contamination heavy/light (Setting for display time to clean air filter) (Sets display time to clean air filter to half when there is heavy filter contamination.)	Super long life filter	Light	Approx. 10,000 hrs.	Heavy	Approx. 5,000 hrs.	—		—	
				Long life filter		Approx. 2,500 hrs.		Approx. 1,250 hrs.				
				Standard filter		Approx. 200 hrs.		Approx. 100 hrs.				
	1		Long life filter type	Long life filter		Super long life filter		—		—		
	2		Thermostat sensor in remote controller	Use		No use		—		—		
	3		Display time to clean air filter calculation (Set when filter sign is not to be displayed.)	Display		No display		—		—		
	12(22)	0		Optional accessories output selection (field selection of output for adaptor for wiring)	Indoor unit turned ON by thermostat				Operation output		Malfunction output	
1			ON/OFF input from outside (Set when ON/OFF is to be controlled from outside.)	Forced OFF		ON/OFF control		—		—		
2			Thermostat differential changeover (Set when remote sensor is to be used.)	1°C		0.5°C		—		—		
3			OFF by thermostat fan speed	LL		Set fan speed		—		—		
4			Automatic mode differential (automatic temperature differential setting for VRV system heat recovery series cool/heat)	01:0	02:1	03:2	04:3	05:4	06:5	07:6	08:7	
5			Power failure automatic reset	Not equipped		Equipped		—		—		
13(23)	0		High air outlet velocity (Set when installed in place with ceiling higher than 2.7 m.)	N		H		S		—		
	1		Selection of air flow direction (Set when a blocking pad kit has been installed.)	F (4 directions)		T (3 directions)		W (2 directions)		—		
	3		Air flow direction adjustment (Set at installation of decoration panel.)	Equipped		Not equipped				—		
	4		Field set air flow position setting	Draft prevention		Standard		Ceiling Soiling prevention		—		
	5		Field set fan speed selection (fan speed control by air discharge outlet for phase control)	Standard		Optional accessory 1		Optional accessory 2		—		
15(25)	1		Thermostat OFF excess humidity	Not equipped		Equipped		—		—		
	2		Direct duct connection (when the indoor unit and heat reclaim ventilation unit are connected by duct directly.) *Note 6	Not equipped		Equipped		—		—		
	3		Drain pump humidifier interlock selection	Not equipped		Equipped		—		—		
	5		Field set selection for individual ventilation setting by remote controller	Not equipped		Equipped		—		—		
	6		Field set selection for individual ventilation setting by remote controller	Not equipped		Equipped		—		—		



- Notes:**
- Settings are made simultaneously for the entire group, however, if you select the mode No. inside parentheses, you can also set by each individual unit. Setting changes however cannot be checked except in the individual mode for those in parentheses.
  - The mode numbers inside parentheses cannot be used by wireless remote controllers, so they cannot be set individually. Setting changes also cannot be checked.
  - Marked **■** are factory set.
  - Do not make settings other than those described above. Nothing is displayed for functions the indoor unit is not equipped with.
  - “88” may be displayed to indicate the remote controller is resetting when returning to the normal mode.
  - If the setting mode to “Equipped”, heat reclaim ventilation fan conducts the fan residual operation by linking to indoor unit.

### 3.1.5 Applicable range of Field setting

	Ceiling mounted cassette type				Slim Ceiling mounted duct type	Ceiling mounted built-in type	Ceiling mounted duct type	Ceiling suspended type	Wall mounted type	Floor standing type	Concealed Floor standing type	New Ceiling suspended cassette type	Outdoor air processing unit
	Multi flow		Double flow	Corner type									
	FXFQ	FXZQ											
	FXDQ	FXSQ	FXMQ	FXHQ	FXAQ	FXLQ	FXNQ	FXUQ	FXMQ- MF				
Filter sign	○	○	○	○	○	○	○	○	○	○	○	○	○
Ultra long life filter sign	○	○	○	—	—	—	—	—	—	—	—	—	—
Remote controller thermostat sensor	○	○	○	○	○	○	○	○	○	○	○	○	—
Set fan speed when thermostat OFF	○	○	○	○	○	○	○	○	○	○	○	○	—
Air flow adjustment Ceiling height	○	—	—	—	—	—	—	○	—	—	—	○	—
Air flow direction	○	○	—	—	—	—	—	—	—	—	—	○	—
Air flow direction adjustment (Down flow operation)	—	—	—	○	—	—	—	—	—	—	—	—	—
Air flow direction adjustment range	○	○	○	○	—	—	—	—	—	—	—	—	—
Field set fan speed selection	○	—	—	—	○*1	—	—	○	—	—	—	—	—
Discharge air temp. (Cooling)	—	—	—	—	—	—	—	—	—	—	—	—	○
Discharge air temp. (Heating)	—	—	—	—	—	—	—	—	—	—	—	—	○

\*1 Static pressure selection

### 3.1.6 Detailed Explanation of Setting Modes

#### Filter Sign Setting

If switching the filter sign ON time, set as given in the table below.

##### Set Time

Setting	Filter Specs.	Standard	Long Life	Ultra Long Life Filter
Contamination Light		200 hrs.	2,500 hrs.	10,000 hrs.
Contamination Heavy		100 hrs.	1,250 hrs.	5,000 hrs.

#### Ultra-Long-Life Filter Sign Setting

When a Ultra-long-life filter is installed, the filter sign timer setting must be changed.

##### Setting Table

Mode No.	Setting Switch No.	Setting Position No.	Setting
10 (20)	1	01	Long-Life Filter
		02	Ultra-Long-Life Filter (1)
		03	—

#### Fan Speed Changeover When Thermostat is OFF

By setting to “Set Fan Speed,” you can switch the fan speed to the set fan speed when the heating thermostat is OFF.

\* Since there is concern about draft if using “fan speed up when thermostat is OFF,” you should take the setup location into consideration.

##### Setting Table

Mode No.	First Code No.	Second Code No.	Setting
12(22)	3	01	LL Fan Speed
		02	Set Fan Speed

#### Auto restart after power failure reset

For the air conditioners with no setting for the function (same as factory setting), the units will be left in the stop condition when the power supply is reset automatically after power failure reset or the main power supply is turned on again after once turned off. However, for the air conditioners with the setting, the units may start automatically after power failure reset or the main power supply turned on again ( return to the same operation condition as that of before power failure).

For the above reasons, when the unit is set enabling to utilize “Auto restart function after power failure reset”, utmost care should be paid for the occurrence of the following situation.



- Caution**
- 1. The air conditioner starts operation suddenly after power failure reset or the main power supply turned on again. Consequently, the user might be surprised (with question for the reason why).**
  - 2. In the service work, for example, turning off the main power switch during the unit is in operation, and turning on the switch again after the work is completed start the unit operation (the fan rotates).**

### Air Flow Adjustment - Ceiling height

Make the following setting according to the ceiling height. The setting position No. is set to "01" at the factory.

#### ■ In the Case of FXAQ, FXHQ

Mode No.	Setting Switch No.	Setting Position No.	Setting
13(23)	0	01	Wall-mounted type: Standard
		02	Wall-mounted type: Slight increase
		03	Wall-mounted type: Normal increase

#### ■ In the Case of FXFQ25~80

Mode No.	First code No.	Second code No.	Setting	Ceiling height		
				4-way Outlets	3-way Outlets	2-way Outlets
13 (23)	0	01	Standard (N)	Lower than 2.7 m	Lower than 3.0 m	Lower than 3.5 m
		02	High Ceiling (H)	Lower than 3.0 m	Lower than 3.3 m	Lower than 3.8 m
		03	Higher Ceiling (S)	Lower than 3.5 m	Lower than 3.5 m	—

#### ■ In the Case of FXFQ100~125

Mode No.	First code No.	Second code No.	Setting	Ceiling height		
				4-way Outlets	3-way Outlets	2-way Outlets
13 (23)	0	01	Standard (N)	Lower than 3.2 m	Lower than 3.6 m	Lower than 4.2 m
		02	High Ceiling (H)	Lower than 3.6 m	Lower than 4.0 m	Lower than 4.2 m
		03	Higher Ceiling (S)	Lower than 4.2 m	Lower than 4.2 m	—

#### ■ In the Case of FXUQ71~125M

Mode No.	First code No.	Second code No.	Setting	Ceiling height		
				4-way Outlets	3-way Outlets	2-way Outlets
13 (23)	0	01	Standard (N)	Lower than 2.7 m	Lower than 3.0 m	Lower than 3.5 m
		02	High Ceiling (H)	Lower than 3.0 m	Lower than 3.5 m	Lower than 3.8 m
		03	Higher Ceiling (S)	Lower than 3.5 m	Lower than 3.8 m	—

### Air Flow Direction Setting

Set the air flow direction of indoor units as given in the table below. (Set when optional air outlet blocking pad has been installed.) The second code No. is factory set to "01."

#### Setting Table

Mode No.	First Code No.	Second Code No.	Setting
13 (23)	1	01	F : 4-direction air flow
		02	T : 3-direction air flow
		03	W : 2-direction air flow

### Setting of Air Flow Direction Adjustment

Only the model FXKQ has the function.

When only the front-flow is used, sets yes/no of the swing flap operation of down-flow.

#### Setting Table

Setting	Mode No.	First Code No.	Second Code No.
Down-flow operation: Yes	13 (23)	3	01
Down-flow operation: No			02



### Setting of Air Flow Direction Adjustment Range

Make the following air flow direction setting according to the respective purpose.

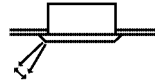

(S2537)

#### Setting Table

Mode No.	First Code No.	Second Code No.	Setting
13 (23)	4	01	Upward (Draft prevention)
		02	Standard
		03	Downward (Ceiling soiling prevention)

### Air flow rate switching at discharge grille for field air flow rate switching

When the optional parts (high performance filter, etc.) is installed, sets to change fan speed for securing air flow rate.

Follow the instruction manual for the optional parts to enter the setting numbers.

### Setting of the static pressure selection (for FXDQ model)

Model No.	First Code No.	Second Code No.	External static pressure
13 (23)	5	01	Standard (15Pa)
		02	High static pressure (44Pa)

### 3.1.7 Outdoor Air Processing Unit-Field Setting (Remote Controller)

Mode No.	Setting SW No.	Setting contents	Setting position No.														
			01	02	03	04	05	06	07	08	09	10	11	12	13	14	15
10 (20)	0	Stain of filter	<b>2500hr</b>	1250hr	—	—	—	—	—	—	—	—	—	—	—	—	—
	3	Filtering time cumulation	Display	No display	—	—	—	—	—	—	—	—	—	—	—	—	—
12 (22)	1	External ON/OFF input	Forced stop	Forced input	—	—	—	—	—	—	—	—	—	—	—	—	—
	5	Power failure automatic reset	Not equipped	Equipped	—	—	—	—	—	—	—	—	—	—	—	—	—
14 (24)	3	Discharge temperature (cooling)	13°C	14	15	16	17	<b>18</b>	19	20	21	22	23	24	25	25	25
	4	Discharge temperature (heating)	18°C	19	20	21	22	23	24	<b>25</b>	26	27	28	29	30	30	30

Note) Bold face in  indicates the default setting.

### 3.1.8 Centralized Control Group No. Setting

#### BRC1A Type

Set the group number of each group of the indoor unit from the remote controller. (In case of no remote controller, also connect the remote controller and set the group No. Then, remove the remote controller.)

1. Turn ON the power of the indoor unit and central remote controller.  
(Unless the power is ON, no setting can be made.)  
Check that the installation and electrical wiring are correct before turning the power supply ON.  
(When the power supply is turned ON, all LCD appear once and the unit may not accept the operation for about one minute with the display of "88".)
2. While in the normal mode, hold down the "TEST" button for a minimum of 4 seconds.  
The remote controller will enter the FIELD SET MODE.
3. Select the MODE No. "00" with the "MODE" button.
4. Use the "UP" button to select the group No. for each group.
5. (Group numbers increase in the order of 1-00, 1-01, ... 1-15, 2-00, ... 4-15.)
6. Press "OK" to set the selected group No.
7. Press "TEST" to return to the NORMAL MODE.

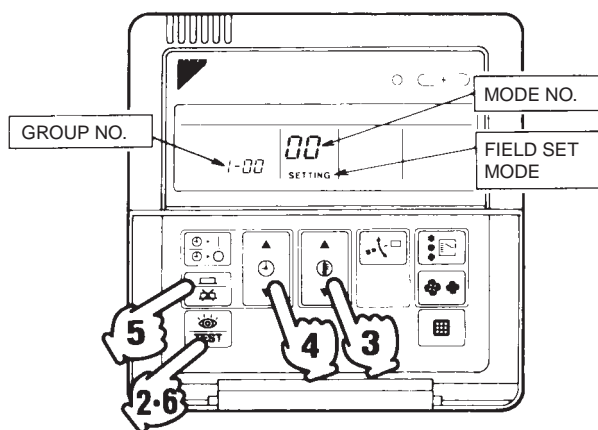

(V0293)







#### Note:

- For simplified remote controller, see the following.
- For setting group No. of HRV and wiring adaptor for other air conditioners, etc., refer to the instruction manual attached.

#### NOTICE

Enter the group No. and installation place of the indoor unit into the attached installation table. Be sure to keep the installation table with the operation manual for maintenance.

**BRC7C Type**

- Group No. setting by wireless remote controller for centralized control
- 1. When in the normal mode, push  button for 4 seconds or more, and operation then enters the "field set mode."
- 2. Set mode No. "00" with  button.
- 3. Set the group No. for each group with   button (advance/backward).
- 4. Enter the selected group numbers by pushing  button.
- 5. Push  button and return to the normal mode.

**BRC7C Type**

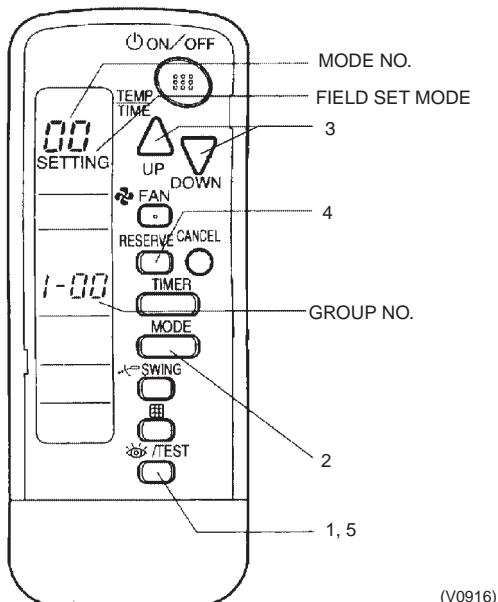

(V0916)

**Group No. Setting Example**

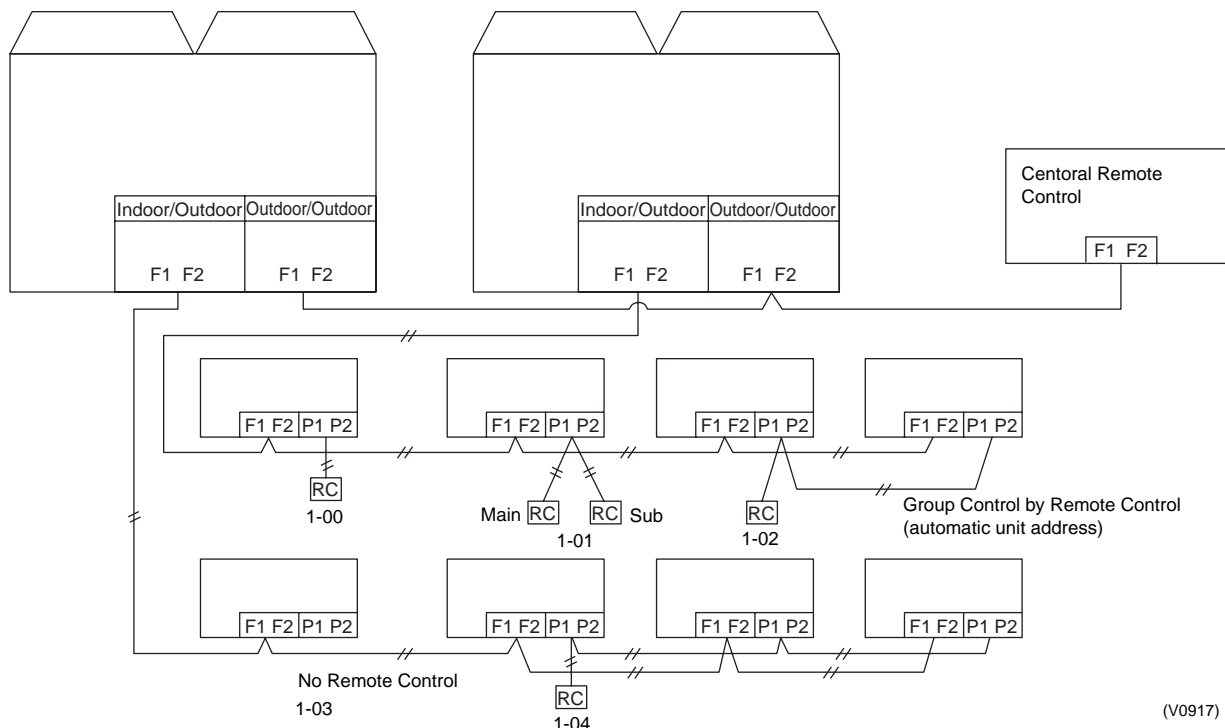

(V0917)



**Caution**

When turning the power supply on, the unit may often not accept any operation while "88" is displaying after all indications were displayed once for about 1 minute on the liquid crystal display. This is not an operative fault.

### 3.1.9 Setting of Operation Control Mode from Remote Controller (Local Setting)

The operation control mode is compatible with a variety of controls and operations by limiting the functions of the operation remote controller. Furthermore, operations such as remote controller ON/OFF can be limited in accordance with the combination conditions. (Refer to information in the table below.)

Centralized controller is normally available for operations. (Except when centralized monitor is connected)

### 3.1.10 Contents of Control Modes

Twenty modes consisting of combinations of the following five operation modes with temperature and operation mode setting by remote controller can be set and displayed by operation modes 0 through 19.

- ◆ ON/OFF control impossible by remote controller  
Used when you want to turn on/off by central remote controller only.  
(Cannot be turned on/off by remote controller.)
- ◆ OFF control only possible by remote controller  
Used when you want to turn on by central remote controller only, and off by remote controller only.
- ◆ Centralized  
Used when you want to turn on by central remote controller only, and turn on/off freely by remote controller during set time.
- ◆ Individual  
Used when you want to turn on/off by both central remote controller and remote controller.
- ◆ Timer operation possible by remote controller  
Used when you want to turn on/off by remote controller during set time and you do not want to start operation by central remote controller when time of system start is programmed.

**How to Select Operation Mode**

Whether operation by remote controller will be possible or not for turning on/off, controlling temperature or setting operation mode is selected and decided by the operation mode given on the right edge of the table below.

**Example**

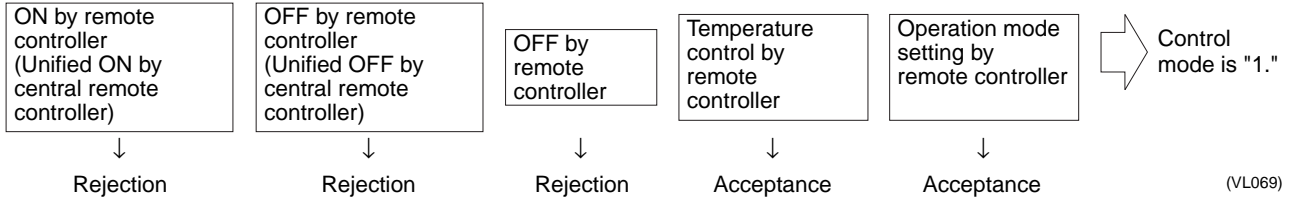

Control mode	Control by remote controller					Control mode
	Operation		OFF	Temperature control	Operation mode setting	
	Unified operation, individual operation by central remote controller, or operation controlled by timer	Unified OFF, individual stop by central remote controller, or timer stop				
ON/OFF control impossible by remote controller	Rejection (Example)	Rejection (Example)	Rejection (Example)	Rejection	Acceptance	0
				Rejection	Rejection	10
OFF control only possible by remote controller	Acceptance	Acceptance	Acceptance	Acceptance (Example)	Acceptance (Example)	1(Example)
				Rejection	Rejection	11
				Rejection	Rejection	12
Centralized	Acceptance	Acceptance	Acceptance	Acceptance	Acceptance	2
				Rejection	Rejection	3
				Rejection	Rejection	13
Individual	Acceptance	Acceptance	Acceptance	Rejection	Acceptance	4
				Rejection	Rejection	14
				Rejection	Rejection	15
Timer operation possible by remote controller	Acceptance (During timer at ON position only)	Acceptance (During timer at ON position only)	Acceptance	Rejection	Acceptance	6
				Rejection	Rejection	16
				Acceptance	Acceptance	<b>7 *1</b>
				Rejection	Rejection	17
Timer operation possible by remote controller	Acceptance (During timer at ON position only)	Acceptance (During timer at ON position only)	Acceptance	Rejection	Acceptance	8
				Rejection	Rejection	18
				Acceptance	Acceptance	9
				Rejection	Rejection	19

Do not select "timer operation possible by remote controller" if not using a remote controller. Operation by timer is impossible in this case.

\*1. Factory setting

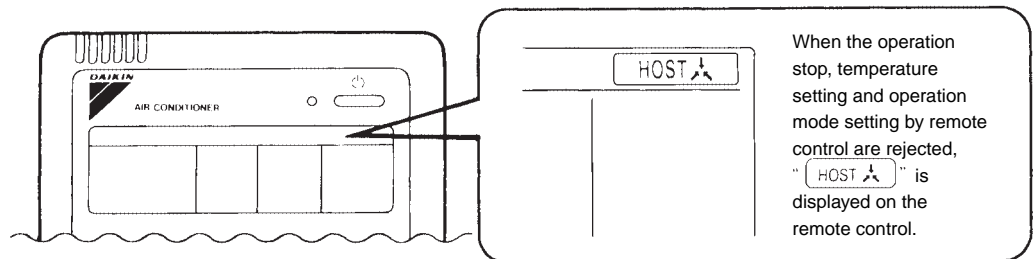

(VL070)

## 3.2 Field Setting from Outdoor Unit

### 3.2.1 Field Setting from Outdoor Unit

■ **Setting by dip switches**

The following field settings are made by dip switches on PC board.

Dipswitch		Setting item	Description
No.	Setting		
DS1-1	ON	Cool / Heat select	Used to set cool / heat select by remote controller equipped with outdoor unit.
	OFF (Factory set)		
DS1-2 ~DS1-4	ON	Not used	Do not change the factory settings.
	OFF (Factory set)		
DS2-1 ~4	ON	Not used	Do not change the factory settings.
	OFF (Factory set)		
DS3-1, 2	ON	Not used	Do not change the factory settings.
	OFF (Factory set)		



**Caution** DIP switch Setting after changing the main P.C.Board(A1P) to spare parts P.C.B.

When you change the main P.C.Board(A1P) to spare parts P.C.B., please carry out the following setting.



**DIP Switch Detail**

DS No.	Item	Contents																																					
DS1-1	Cool/Heat change over setting	ON	The Cool/Heat change over setting is carried out by COOL/HEAT changeover remote controller fitted to outdoor unit.																																				
		OFF	The Cool/Heat change over setting is not carried out by COOL/HEAT changeover remote controller fitted to outdoor unit.																																				
DS1-2	Power supply specification	ON	200V (mainly domestic Japan)																																				
		OFF	400V (mainly overseas)																																				
DS1-3	Cooling only/Heat-pump setting	ON	Cooling only																																				
		OFF	Heat-pump																																				
DS1-4	New/previous unit setting	ON	• Production after January 2004 :ON																																				
		OFF (Spare parts PCB)	• Production before December 2003 :OFF																																				
DS2-1	Domestic Japan or overseas setting	ON	• Overseas :ON																																				
		OFF (Spare parts PCB)	• Domestic Japan :OFF																																				
DS2-2	HP setting (Horse power) (Factory setting of spare parts PCB are all OFF)	<table border="1"> <thead> <tr> <th></th> <th>5</th> <th>8</th> <th>10</th> <th>12</th> <th>14</th> <th>16</th> <th>HP</th> </tr> </thead> <tbody> <tr> <td>DS2-2</td> <td>OFF</td> <td>OFF</td> <td>ON</td> <td>OFF</td> <td>ON</td> <td>OFF</td> <td></td> </tr> <tr> <td>DS2-3</td> <td>OFF</td> <td>ON</td> <td>ON</td> <td>OFF</td> <td>OFF</td> <td>ON</td> <td></td> </tr> <tr> <td>DS2-4</td> <td>OFF</td> <td>OFF</td> <td>OFF</td> <td>ON</td> <td>ON</td> <td>ON</td> <td></td> </tr> </tbody> </table>							5	8	10	12	14	16	HP	DS2-2	OFF	OFF	ON	OFF	ON	OFF		DS2-3	OFF	ON	ON	OFF	OFF	ON		DS2-4	OFF	OFF	OFF	ON	ON	ON	
		5	8	10	12	14	16	HP																															
DS2-2		OFF	OFF	ON	OFF	ON	OFF																																
DS2-3	OFF	ON	ON	OFF	OFF	ON																																	
DS2-4	OFF	OFF	OFF	ON	ON	ON																																	
DS2-3	DS2-2	OFF	OFF	ON	OFF	ON																																	
DS2-4	DS2-3	OFF	OFF	OFF	ON	ON																																	
DS2-4	DS2-4	OFF	OFF	OFF	ON	ON																																	

\* If the DS1-4,DS2-1 setting(refrigerant classification) has not been carried out, error code "UA" is displayed and unit can not be operated.



Refer "DS1-4, DS2-1~4 setting detail" on next page.

## "Detail of DS1-4, DS2-1~4 setting"

Previous unit	Mfg. No.	Setting method ( ■ represents the position of switches)	
HEAT PUNP(5HP) RXYQ5MY1B	6300001~6300272	On Off	Set DS2-1 to ON.
HEAT PUNP(8HP) RXYQ8MY1B	6300001~6300491	On Off	Set DS2-1 and DS2-3 to ON.
HEAT PUNP(10HP) RXYQ10MY1B	6300001~6301014	On Off	Set DS2-1, DS2-2 and DS2-3 to ON.
HEAT PUNP(12HP) RXYQ12MY1B	6300001~6300276	On Off	Set DS2-1 and DS2-4 to ON.
HEAT PUNP(14HP) RXYQ14MY1B	6300001~6300314	On Off	Set DS2-1, DS2-2 and DS2-4 to ON.
HEAT PUNP(16HP) RXYQ16MY1B	6300001~6300500	On Off	Set DS2-1, DS2-3 and DS2-4 to ON.
New unit	Mfg. No.	Setting method ( ■ represents the position of switches)	
HEAT PUNP(5HP) RXYQ5MY1B	6300273~	On Off	Set DS1-4 and DS2-1 to ON.
HEAT PUNP(8HP) RXYQ8MY1B	6300492~	On Off	Set DS1-4, DS2-1 and DS2-3 to ON.
HEAT PUNP(10HP) RXYQ10MY1B	6301015~	On Off	Set DS1-4, DS2-1, DS2-2 and DS2-3 to ON.
HEAT PUNP(12HP) RXYQ12MY1B	6300277~	On Off	Set DS1-4, DS2-1 and DS2-4 to ON.
HEAT PUNP(14HP) RXYQ14MY1B	6300315~	On Off	Set DS1-4, DS2-1, DS2-2 and DS2-4 to ON.
HEAT PUNP(16HP) RXYQ16MY1B	6300501~	On Off	Set DS1-4, DS2-1, DS2-3 and DS2-4 to ON.



■ **Setting by pushbutton switches**

The following settings are made by pushbutton switches on PC board.

In case of multi-outdoor unit system, various items should be set with the master unit.

(Setting with the slave unit is disabled.)

The master unit and slave unit can be discriminated with the LED indication as shown below.

	H1P	H2P	H3P	H4P	H5P	H6P	H7P	H8P
Master unit	●	●	○	●	●	●	●	○
Slave unit 1	●	●	●	●	●	●	●	◐
Slave unit 2	●	●	●	●	●	●	●	●

(Factory setting)

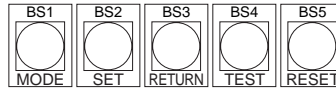

(V2760)

There are the following three setting modes.

① **Setting mode 1 (H1P off)**

Initial status (when normal) : Used to select the cool/heat setting. Also indicates during “abnormal”, “low noise control” and “demand control”.

② **Setting mode 2 (H1P on)**

Used to modify the operating status and to set program addresses, etc. Usually used in servicing the system.

③ **Monitor mode (H1P blinks)**

Used to check the program made in Setting mode 2.

■ **Mode changing procedure**

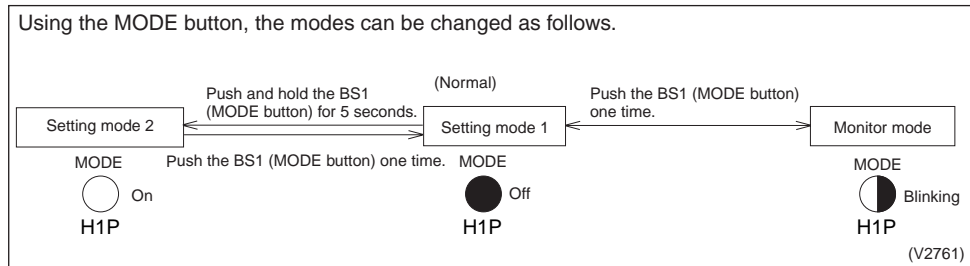

■ **Mode changing procedure**

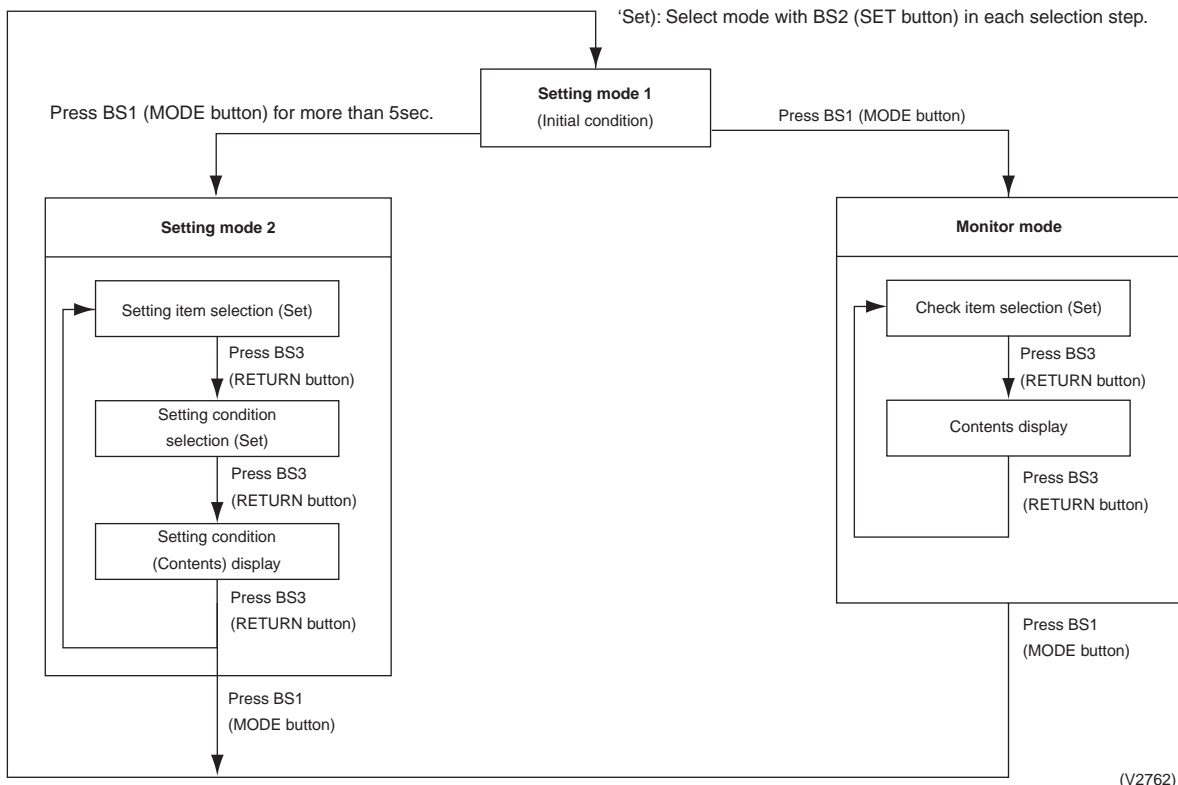

### a. "Setting mode 1"

"Normally, "Setting mode 1" is set. In case of other status, push MODE button (BS1) one time and set to "Setting mode 1".

#### <Selection of setting items>

Push the SET button (BS2) and set LED display to a setting item you want.

- Regarding setting item No. 1,5,6, only the present status is displayed. For the respective description, refer to the table shown on lower right.
- The cool/heat selection setting can be changed on setting item 2, 3, 4. → After setting, push the RETURN button (BS3) and decide the item.

When the RETURN button (BS3) is pushed, the status becomes the initial status of "Setting mode 1".

(V2763)

No.	Setting (displaying) item	LED display example						
		H1P	H2P	H3P	H4P	H5P	H6P	H7P
1	Display for malfunction / preparing / test run *	●	●	○	●	●	●	●
2	C/H selector (individual)	●	●	○	●	●	●	●
3	C/H selector (Master)	●	●	●	○	●	●	●
4	C/H selector (Slave)	●	●	●	●	○	●	●
5	Low noise operation *	●	●	○	●	●	●	●
6	Demand operation *	●	●	○	●	●	●	●

\* Setting No. 1, 5, 6 are the present status display only.

#### Display for malfunction/preparing/test-run

Normal	●	●	○	●	●	●	●
Malfunction	●	○	○	●	●	●	●
Preparing/Test-run	●	◐	○	●	●	●	●

#### Display during low noise operation

Normal	●	●	○	●	●	●	●
During low noise operation	●	●	○	●	●	○	●

H3P to H5P LED display changes depending on setting No. 2, 3, 4.

#### Display during demand operation

Normal	●	●	○	●	●	●	●
During demand operation	●	●	○	●	●	●	○

H3P to H5P LED display changes depending on setting No. 2, 3, 4.

○	: ON
●	: OFF
◐	: Blinking

## b. "Setting mode 2"

Push and hold the MODE button (BS1) for 5 seconds and set to "Setting mode 2".

## &lt;Selection of setting items&gt;

Push the SET button (BS2) and set the LED display to a setting item shown in the table on the right.

↓  
Push the RETURN button (BS3) and decide the item. (The present setting condition is blinked.)

## &lt;Selection of setting conditions&gt;

Push the SET button (BS2) and set to the setting condition you want.

↓  
Push the RETURN button (BS3) and decide the condition.

Push the RETURN button (BS3) and set to the initial status of "Setting mode 2".

\* If you become unsure of how to proceed, push the MODE button (BS1) and return to setting mode 1.

(V2764)

No.	Setting item	Description
0	EMG (Emergency operation 1)	Operates by Standard compressor only when inverter compressor malfunctions. Temporary operation until the compressor is replaced. Since the comfortability is extremely deteriorated, immediately replace the compressor. (This setting is not applicable to RXYQ5M.)
1	Cool/heat unified address	Sets address for cool/heat unified operation.
2	Low noise/demand address	Address for low noise/demand operation
5	Indoor unit forced fan H	Allows forced operation of indoor unit fan while unit is stopped. (H tap)
6	Indoor unit forced operation	Allows forced operation of indoor unit.
8	Te setting	Target evaporation temperature for cooling
9	Tc setting	Target condensation temperature for heating
10	Defrost changeover setting	Changes the temperature condition for defrost and sets to quick defrost or slow defrost.
11	Sequential operation setting	Sets sequential operation
12	External low noise setting / Demand setting	Reception of external low noise or demand signal
13	AIRNET address	Set address for AIRNET.
18	High static pressure setting	Make this setting in the case of operating in high static pressure mode with diffuser duct mounted.
19	Emergency operation (STD compressor operation prohibited)	Used to operate system only with inverter compressor when STD compressor malfunctions. This is a temporary operation extremely impairing comfortable environment. Therefore, prompt replacement of the compressor is required. (This operation, however, is not set with RXYQ5M.)
20	Additional refrigerant charge operation setting	Carries out additional refrigerant charge operation.
21	Refrigerant collection mode setting	Sets to refrigerant collection mode.
22	Night-time low noise setting	Sets automatic nighttime low noise operation in a simple way. The operating time is based on "Starting set" and "Ending set".
25	Low noise setting	Sets low noise level when the low noise signal is input from outside.
26	Night-time low noise control starting setting	Sets starting time of nighttime low noise operation. (Nighttime low noise setting is also required.)
27	Night-time low noise control ending setting	Sets ending time of nighttime low noise operation. (Nighttime low noise setting is also required.)
28	Power transistor check mode *Check after disconnection of compressor wires	Used for trouble diagnosis of DC compressor. Since the waveform of inverter is output without wiring to the compressor, it is convenient to probe whether the trouble comes from the compressor or PC board.
29	Capacity precedence setting	If the capacity control is required, the low noise control is automatically released by this setting during carrying out low noise operation and nighttime low noise operation.
30	Demand setting 1	Changes target value of power consumption when demand control 1 is input.
32	Normal demand setting	Normally enables demand control 1 without external input. (Effective to prevent a problem that circuit breaker of small capacity is shut down due to large load.)

No.	Setting item	Description
38	Emergency operation (Setting for the master unit operation prohibition in multi-outdoor-unit system)	Used to temporarily prohibit the applicable outdoor unit from operating should there be any faulty part in multi-outdoor-unit system. Since the comfortable environment is extremely impaired, prompt replacement of the part is required.
39	Emergency operation (Setting for the slave unit 1 operation prohibition in multi-outdoor-unit system)	
40	Emergency operation (Setting for the slave unit 2 operation prohibition in multi-outdoor-unit system)	

No.	Setting item display								Setting condition display							
	Setting item	MODE H1P	TEST H2P	C/H selection			Low noise H6P	Demand H7P								
				IND H3P	Master H4P	Slave H5P										
0	EMG (emergency operation) INV compressor operation inhibited.	<input type="radio"/>	<input checked="" type="radio"/>	<input checked="" type="radio"/>	<input checked="" type="radio"/>	<input checked="" type="radio"/>	<input checked="" type="radio"/>	<input checked="" type="radio"/>	Normal operation	<input type="radio"/> ● ● ● ● ● ● ● ● *	Emergency operation	<input type="radio"/> ● ● ● ● ● ● ● ●				
1	Cool / Heat Unified address	<input type="radio"/>	<input checked="" type="radio"/>	<input checked="" type="radio"/>	<input checked="" type="radio"/>	<input checked="" type="radio"/>	<input checked="" type="radio"/>	<input type="radio"/>	Address 0	<input type="radio"/> ● ● ● ● ● ● ● ● *	Binary number (6 digits)	1 <input type="radio"/> ● ● ● ● ● ● ● ● ~ 31 <input type="radio"/> ● ● ● ● ● ● ● ●				
2	Low noise/demand address	<input type="radio"/>	<input checked="" type="radio"/>	<input checked="" type="radio"/>	<input checked="" type="radio"/>	<input checked="" type="radio"/>	<input type="radio"/>	<input checked="" type="radio"/>	Address 0	<input type="radio"/> ● ● ● ● ● ● ● ● *	Binary number (6 digits)	1 <input type="radio"/> ● ● ● ● ● ● ● ● ~ 31 <input type="radio"/> ● ● ● ● ● ● ● ●				
5	Indoor forced fan H	<input type="radio"/>	<input checked="" type="radio"/>	<input checked="" type="radio"/>	<input checked="" type="radio"/>	<input type="radio"/>	<input checked="" type="radio"/>	<input type="radio"/>	Normal operation	<input type="radio"/> ● ● ● ● ● ● ● ● *	Indoor forced fan H	<input type="radio"/> ● ● ● ● ● ● ● ●				
6	Indoor forced operation	<input type="radio"/>	<input checked="" type="radio"/>	<input checked="" type="radio"/>	<input checked="" type="radio"/>	<input type="radio"/>	<input type="radio"/>	<input checked="" type="radio"/>	Normal operation	<input type="radio"/> ● ● ● ● ● ● ● ● *	Indoor forced operation	<input type="radio"/> ● ● ● ● ● ● ● ●				
8	Te setting	<input type="radio"/>	<input checked="" type="radio"/>	<input checked="" type="radio"/>	<input type="radio"/>	<input checked="" type="radio"/>	<input checked="" type="radio"/>	<input checked="" type="radio"/>	High	<input type="radio"/> ● ● ● ● ● ● ● ●	Normal (factory setting)	<input type="radio"/> ● ● ● ● ● ● ● ● *	Low	<input type="radio"/> ● ● ● ● ● ● ● ●		
9	Tc setting	<input type="radio"/>	<input checked="" type="radio"/>	<input checked="" type="radio"/>	<input type="radio"/>	<input checked="" type="radio"/>	<input checked="" type="radio"/>	<input type="radio"/>	High	<input type="radio"/> ● ● ● ● ● ● ● ●	Normal (factory setting)	<input type="radio"/> ● ● ● ● ● ● ● ● *	Low	<input type="radio"/> ● ● ● ● ● ● ● ●		
10	Defrost setting	<input type="radio"/>	<input checked="" type="radio"/>	<input checked="" type="radio"/>	<input type="radio"/>	<input checked="" type="radio"/>	<input type="radio"/>	<input checked="" type="radio"/>	Quick defrost	<input type="radio"/> ● ● ● ● ● ● ● ●	Normal (factory setting)	<input type="radio"/> ● ● ● ● ● ● ● ● *	Slow defrost	<input type="radio"/> ● ● ● ● ● ● ● ●		
11	Sequential operation setting	<input type="radio"/>	<input checked="" type="radio"/>	<input checked="" type="radio"/>	<input type="radio"/>	<input checked="" type="radio"/>	<input type="radio"/>	<input type="radio"/>	OFF	<input type="radio"/> ● ● ● ● ● ● ● ●	ON	<input type="radio"/> ● ● ● ● ● ● ● ● *				
12	External low noise/demand setting	<input type="radio"/>	<input checked="" type="radio"/>	<input checked="" type="radio"/>	<input type="radio"/>	<input type="radio"/>	<input checked="" type="radio"/>	<input checked="" type="radio"/>	External low noise/demand: NO	<input type="radio"/> ● ● ● ● ● ● ● ● *	External low noise/demand: YES	<input type="radio"/> ● ● ● ● ● ● ● ●				
13	Airnet address	<input type="radio"/>	<input checked="" type="radio"/>	<input checked="" type="radio"/>	<input type="radio"/>	<input type="radio"/>	<input checked="" type="radio"/>	<input type="radio"/>	Address 0	<input type="radio"/> ● ● ● ● ● ● ● ● *	Binary number (6 digits)	1 <input type="radio"/> ● ● ● ● ● ● ● ● ~ 63 <input type="radio"/> ● ● ● ● ● ● ● ●				
18	High static pressure setting	<input type="radio"/>	<input checked="" type="radio"/>	<input type="radio"/>	<input checked="" type="radio"/>	<input checked="" type="radio"/>	<input type="radio"/>	<input checked="" type="radio"/>	High static pressure setting: OFF	<input type="radio"/> ● ● ● ● ● ● ● ● *	High static pressure setting: ON	<input type="radio"/> ● ● ● ● ● ● ● ●				
19	Emergency operation (STD compressor is inhibited to operate.)	<input type="radio"/>	<input checked="" type="radio"/>	<input type="radio"/>	<input checked="" type="radio"/>	<input checked="" type="radio"/>	<input type="radio"/>	<input type="radio"/>	OFF	<input type="radio"/> ● ● ● ● ● ● ● ● *	STD 1, 2 operation: Inhibited	<input type="radio"/> ● ● ● ● ● ● ● ●	STD 2 operation: Inhibited	<input type="radio"/> ● ● ● ● ● ● ● ●		
20	Additional refrigerant operation setting	<input type="radio"/>	<input checked="" type="radio"/>	<input type="radio"/>	<input checked="" type="radio"/>	<input type="radio"/>	<input checked="" type="radio"/>	<input checked="" type="radio"/>	Refrigerant charging: OFF	<input type="radio"/> ● ● ● ● ● ● ● ● *	Refrigerant charging: ON	<input type="radio"/> ● ● ● ● ● ● ● ●				
21	Refrigerant recovery mode setting	<input type="radio"/>	<input checked="" type="radio"/>	<input type="radio"/>	<input checked="" type="radio"/>	<input type="radio"/>	<input checked="" type="radio"/>	<input type="radio"/>	Refrigerant recovery: OFF	<input type="radio"/> ● ● ● ● ● ● ● ● *	Refrigerant recovery: ON	<input type="radio"/> ● ● ● ● ● ● ● ●				
22	Night-time low noise setting	<input type="radio"/>	<input checked="" type="radio"/>	<input type="radio"/>	<input checked="" type="radio"/>	<input type="radio"/>	<input type="radio"/>	<input checked="" type="radio"/>	OFF	<input type="radio"/> ● ● ● ● ● ● ● ● *	Level 1 (outdoor fan with 8 step or lower)	<input type="radio"/> ● ● ● ● ● ● ● ●	Level 2 (outdoor fan with 7 step or lower)	<input type="radio"/> ● ● ● ● ● ● ● ●	Level 3 (outdoor fan with 6 step or lower)	<input type="radio"/> ● ● ● ● ● ● ● ●
25	Low noise setting	<input type="radio"/>	<input checked="" type="radio"/>	<input type="radio"/>	<input type="radio"/>	<input checked="" type="radio"/>	<input checked="" type="radio"/>	<input type="radio"/>	Level 1 (outdoor fan with 8 step or lower)	<input type="radio"/> ● ● ● ● ● ● ● ●	Level 2 (outdoor fan with 7 step or lower)	<input type="radio"/> ● ● ● ● ● ● ● ● *	Level 3 (outdoor fan with 6 step or lower) *	<input type="radio"/> ● ● ● ● ● ● ● ●		

No.	Setting item display								Setting condition display	
	Setting item	MODE H1P	TEST H2P	C/H selection			Low noise H6P	Demand H7P		
				IND H3P	Master H4P	Slave H5P				
26	Night-time low noise operation start setting	○	●	○	○	●	○	●	About 20:00	○ ● ● ● ● ● ○
									About 22:00 (factory	○ ● ● ● ● ○ ● *
									About 24:00	○ ● ● ● ○ ● ●
27	Night-time low noise operation end setting	○	●	○	○	●	○	○	About 6:00	○ ● ● ● ● ● ○
									About 7:00	○ ● ● ● ● ○ ●
									About 8:00 (factory setting)	○ ● ● ● ○ ● ● *
28	Power transistor check mode	○	●	○	○	○	●	●	OFF	○ ● ● ● ● ● ○ *
									ON	○ ● ● ● ● ○ ●
29	Capacity precedence setting	○	●	○	○	○	●	○	OFF	○ ● ● ● ● ● ○ *
									ON	○ ● ● ● ● ○ ●
30	Demand setting 1	○	●	○	○	○	○	●	60 % demand	○ ● ● ● ● ● ○
									70 % demand	○ ● ● ● ● ○ ● *
									80 % demand	○ ● ● ● ○ ● ●
32	Continuous demand setting	○	○	●	●	●	●	●	OFF	○ ● ● ● ● ● ○ *
									ON	○ ● ● ● ● ○ ●
38	Emergency operation (Master unit with multi-outdoor-unit system is inhibited to operate.)	○	○	●	●	○	○	●	OFF	○ ● ● ● ● ● ○ *
									Master unit operation: Inhibited	○ ● ● ● ● ○ ●
39	Emergency operation (Slave unit 1 with multi-outdoor-unit system is inhibited to operate.)	○	○	●	●	○	○	○	OFF	○ ● ● ● ● ● ○ *
									Slave unit 1 operation: Inhibited	○ ● ● ● ● ○ ●
40	Emergency operation (Slave unit 2 with multi-outdoor-unit system is inhibited to operate.)	○	○	●	○	●	●	●	OFF	○ ● ● ● ● ● ○ *
									Slave unit 2 operation: Inhibited	○ ● ● ● ● ○ ●

**c. Monitor mode**

To enter the monitor mode, push the MODE button (BS1) when in "Setting mode 1".

**<Selection of setting item>**

Push the SET button (BS2) and set the LED display to a setting item.

**<Confirmation on setting contents>**

Push the RETURN button (BS3) to display different data of set items.

Push the RETURN button (BS3) and switches to the initial status of "Monitor mode".

\* Push the MODE button (BS1) and returns to "Setting mode 1".

(V2765)

No.	Setting item	LED display							Data display
		H1P	H2P	H3P	H4P	H5P	H6P	H7P	
0	Number of units for sequential starting, and others	●	●	●	●	●	●	●	See below
1	C/H unified address	●	●	●	●	●	●	○	Lower 6 digits
2	Low noise/demand address	●	●	●	●	●	○	●	
3	Not used	●	●	●	●	●	○	○	
4	Airnet address	●	●	●	●	○	●	●	
5	Number of connected indoor units	●	●	●	●	○	●	○	
6	Number of connected BS units	●	●	●	●	○	○	●	
7	Number of connected zone units (excluding outdoor and BS unit)	●	●	●	●	○	○	○	Lower 4 digits: upper
8	Number of outdoor units	●	●	●	○	●	●	●	
9	Number of connected BS units	●	●	●	○	●	●	○	Lower 4 digits: lower
10	Number of connected BS units	●	●	●	○	●	○	●	Lower 6 digits
11	Number of zone units (excluding outdoor and BS unit)	●	●	●	○	●	○	○	Lower 4 digits: upper
12	Number of terminal blocks	●	●	●	○	○	●	●	Lower 4 digits: lower
13	Number of terminal blocks	●	●	●	○	○	●	○	Malfunction code table Refer page 171, 172.
14	Contents of malfunction (the latest)	○	●	●	○	○	○	●	
15	Contents of malfunction (1 cycle before)	○	●	●	○	○	○	○	
16	Contents of malfunction (2 cycle before)	○	●	○	●	●	●	●	
20	Contents of retry (the latest)	○	●	○	●	○	●	●	
21	Contents of retry (1 cycle before)	○	●	○	●	○	●	○	
22	Contents of retry (2 cycle before)	○	●	○	●	○	○	●	

**Setting item 0 Display contents of "Number of units for sequential start, and others"**

Number of units for sequential start	1 unit	●	●	●	●	●	●	●
	2 units	●	●	○	●	●	●	●
	3 units	●	●	○	○	●	●	●
EMG operation /backup operation setting	ON	●	●	●	○	●	●	●
	OFF	●	●	●	●	●	●	●
Defrost select setting	Short	●	●	●	●	○	●	●
	Medium	●	●	●	●	○	●	●
	Long	●	●	●	●	●	●	●
Te setting	H	●	●	●	●	○	●	●
	M	●	●	●	●	●	○	●
	L	●	●	●	●	●	●	●
Tc setting	H	●	●	●	●	●	○	●
	M	●	●	●	●	●	●	○
	L	●	●	●	●	●	●	●

Push the SET button and match with the LEDs No. 1 - 15, push the RETURN button, and enter the data for each setting.

H Data such as addresses and number of units is expressed as binary numbers; the two ways of expressing are as follows:

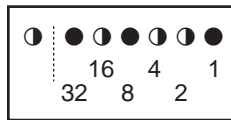

The No. 1 cool/heat unified address is expressed as a binary number consisting of the lower 6 digits. (0 - 63)

In ① the address is 010110 (binary number), which translates to  $16 + 4 + 2 = 22$  (base 10 number). In other words, the address is 22.

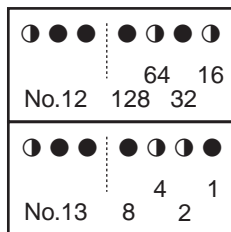

The number of terminal blocks for No. 12 and 13 is expressed as an 8-digit binary number, which is the combination of four upper, and four lower digits for No. 12 and 13 respectively. (0 - 128)

In ② the address for No. 12 is 0101, the address for No. 13 is 0110, and the combination of the two is 01010110 (binary number), which translates to  $64 + 16 + 4 + 2 = 86$  (base 10 number). In other words, the number of terminal block is 86.

H See the preceding page for a list of data, etc. for No. 0 - 22.



## 3.2.2 Cool / Heat Mode Switching

There are the following 5 cool/heat switching modes.

- ① Set cool/heat separately for each outdoor unit system by indoor unit remote controller.
- ② Set cool/heat separately for each outdoor unit system by cool/heat switching remote controller.
- ③ Set cool/heat for more than one outdoor unit system simultaneously in accordance with unified master outdoor unit by indoor unit remote controller.
- ④ Set cool/heat for more than one outdoor unit system simultaneously in accordance with unified master outdoor unit by cool/heat switching remote controller.

### ① Set Cool/Heat Separately for Each Outdoor System by Indoor Unit Remote Controller

- ◆ It does not matter whether or not there is outdoor - outdoor unit wiring.
- ◆ Set outdoor unit PC board DS1-1 to "indoor" (factory set).
- ◆ Set cool/heat switching to "individual" for "Setting mode 1" (factory set).

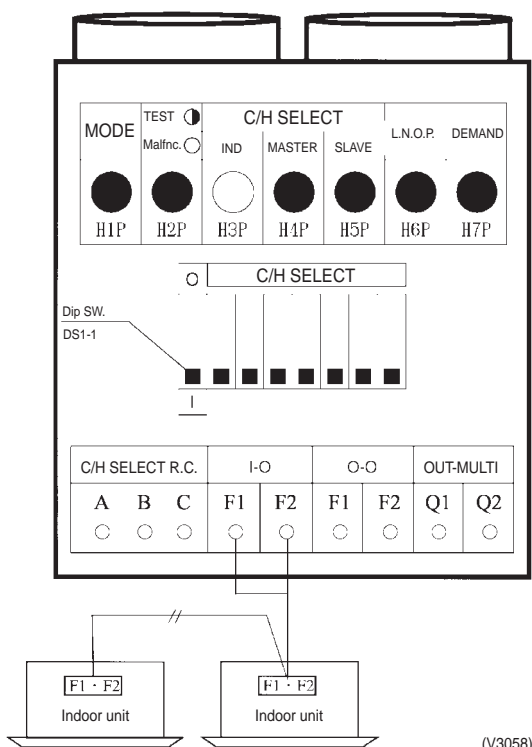

② Set Cool / Heat Separately for Each Outdoor Unit System by Cool/Heat Switching Remote Controller

- ◆ It does not matter whether or not there is outdoor - outdoor unit wiring.
- ◆ Set outdoor unit PC board DS1-1 to "outdoor" (factory set).
- ◆ Set cool/heat switching to "individual" for "Setting mode 1" (factory set).

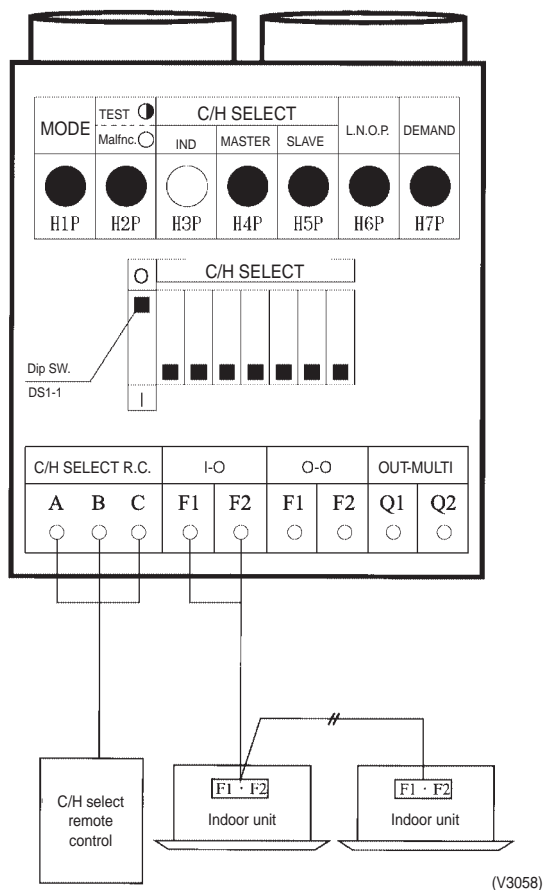

③ Set Cool / Heat for More Than One Outdoor Unit System Simultaneously in Accordance with Unified Master Outdoor Unit by Indoor Unit Remote Controller

- ◆ Install the outdoor unit external control adapter on either the outdoor-outdoor, indoor-outdoor, or transmission line.
- ◆ Set outdoor unit PC board DS1-1 to "Indoor" (factory set).
- ◆ In setting mode 1, set the outdoor unit you want to give cool/heat selection permission to as the group master, and set the other outdoor units as group slave units.
- ◆ Set the outdoor unit external control adapter SS1 to Unified (factory set) or Cool, and SS2 to No (factory set).

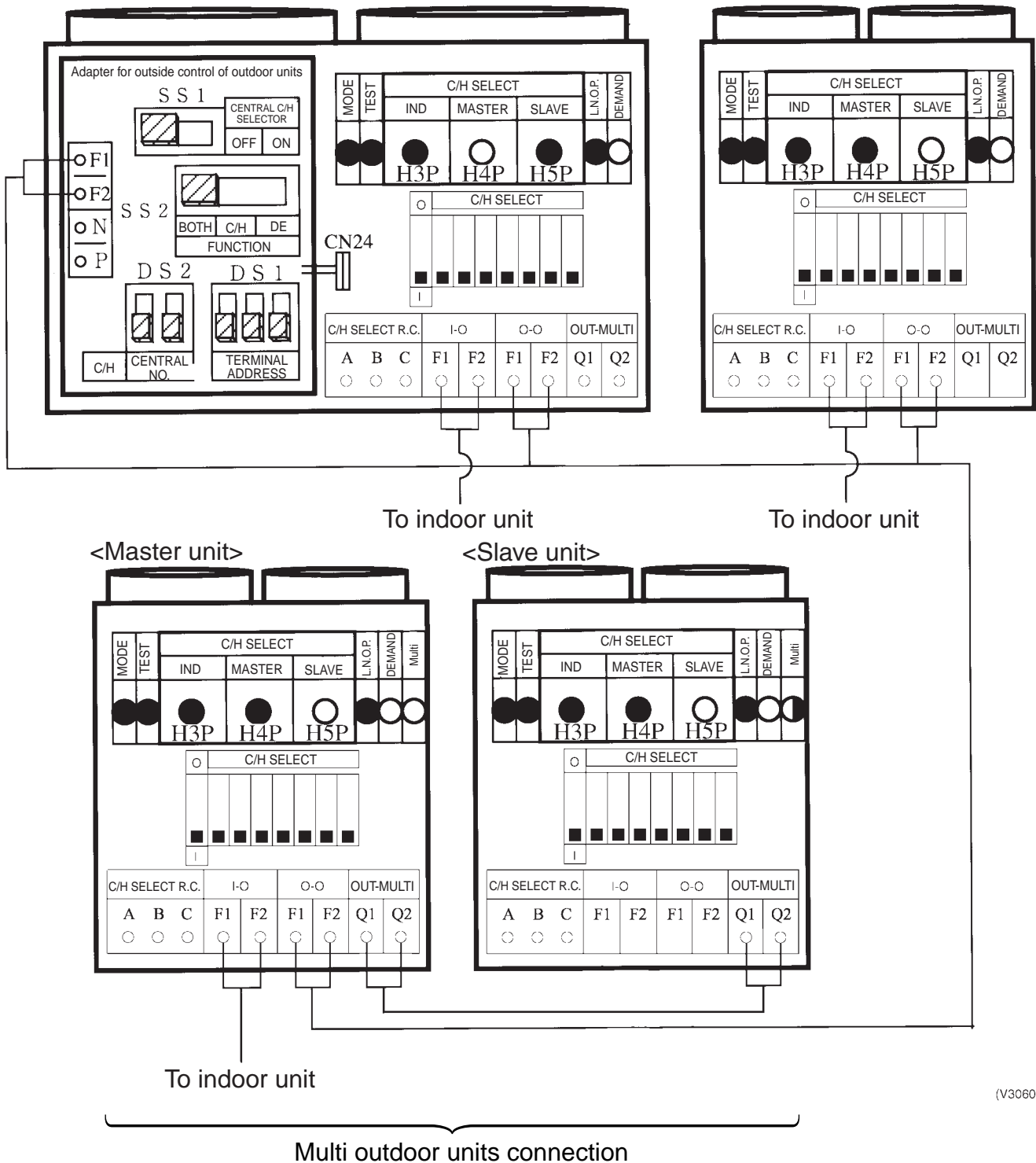

(V3060)

④ Set Cool / Heat for More Than One Outdoor Unit System Simultaneously in Accordance with Unified Master Outdoor Unit by Cool/Heat Switching Remote Controller

◆ Add and change the following items to ③.

H Install cool/heat switching remote controller on the group master outdoor unit.

H Set SS1 on the group master outdoor unit PC board.

Supplementation on ③ and ④.

When switching cool/heat for each adapter PC board with the use of more than one adapter PC board, set the address of the adapter PC board DS1 and DS2 so that it matches the unified cool/heat address of outdoor unit PC board.

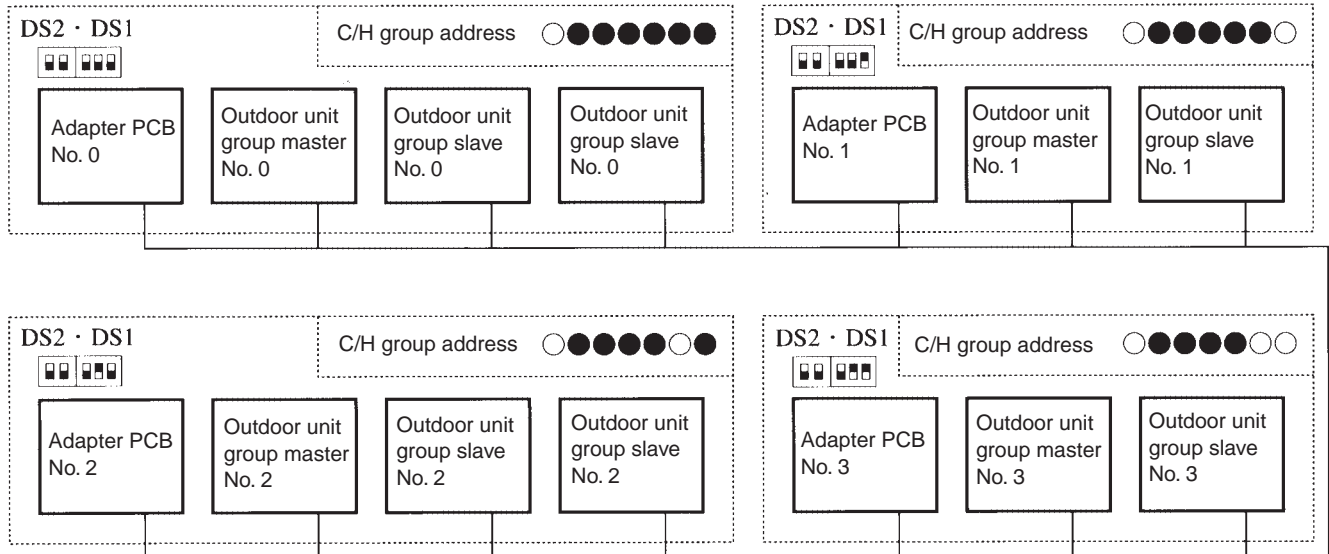

(V2723)

Address setting for ③ and ④ (Set lower 5 digits with binary number.) [No.0 to No.31]

Address No.	Outdoor unit PCB LED Set with setting mode 2		Adapter PCB					
			DS2		DS1			
No. 0	○ ●	● ● ● ● ● 0						0
No. 1	○ ●	● ● ● ● ○ 1						1
No. 2	○ ●	● ● ● ○ ● 2						2
No. 3	○ ●	● ● ● ○ ○ 3						3
No. 4	○ ●	● ● ○ ● ● 4						4
}	}	}	}					
No. 30	○ ●	○ ○ ○ ○ ● 30						30
No. 31	○ ●	○ ○ ○ ○ ○ 31						31

○ ON ● OFF      Upper position (ON)      lower position (OFF)  
(The shaded part shows knob)

(V2724)

### 3.2.3 Setting of Low Noise Operation and Demand Operation

---

#### Setting of Low Noise Operation

By connecting the external contact input to the low noise input of the outdoor unit external control adapter (optional), you can lower operating noise by 2-3 dB.

**A. When the low noise operation is carried out by external instructions (with the use of the outdoor unit external control adapter)**

1. Set "External low noise / Demand YES/NO setting" to "External low noise / Demand YES". (Set by Setting Mode 2)
2. Set "External low noise level setting" on the outdoor unit PC board, as the need arises. (Lower noise operation can be carried out by "Mode 2" than by "Mode 1", and by "Mode 3" than by "Mode 2".)
3. Set "Capacity precedence setting" on the outdoor unit PC board, as the need arises. (If set to "ON", when air conditioning load gets higher, the low noise instructions are neglected to switch to normal operation.) (Set by Setting Mode 2)

**B. When the low noise operation is carried out automatically at night (The outdoor unit external control adapter is not required)**

1. Set "Night-time low noise setting" on the outdoor unit PC board. (Set by Setting Mode 2) (Lower noise operation can be carried out by "Mode 2" than by "Mode 1", and by "Mode 3" than by "Mode 2".)
2. Set "Night-time low noise start setting" on the outdoor unit PC board, as the need arises. (Set by Setting Mode 2) (Since the time is presumed in accordance with the outdoor temperature, the starting time is a target only.)
3. Set "Night-time low noise end setting" on the outdoor unit PC board, as the need arises. (Set by Setting Mode 2) (Since the time is presumed in accordance with the outdoor temperature, the ending time is a target only.)
4. Set "Capacity precedence setting" on the outdoor unit PC board, as the need arises. (Set by Setting Mode 2) (If set to "ON", when air conditioning load gets higher, the status is switched to normal operation even at night.)

Image of operation in the case of A

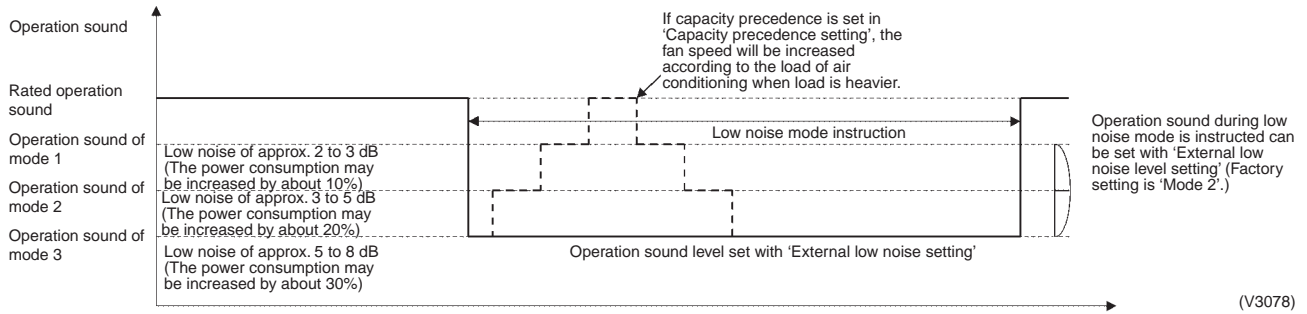

Image of operation in the case of B

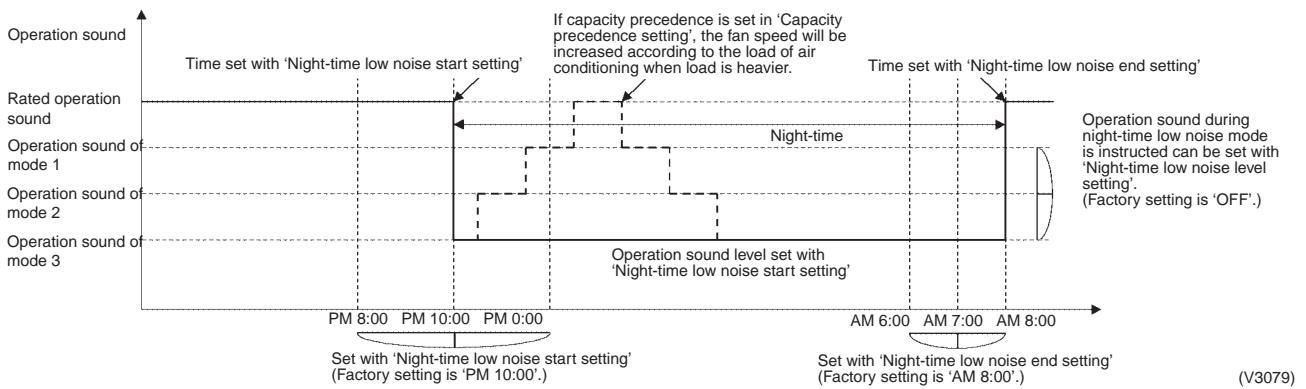
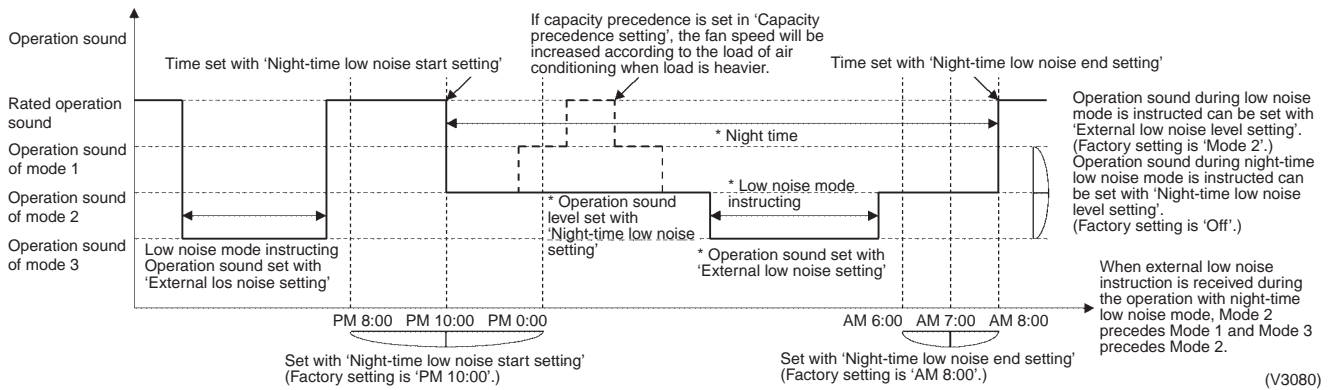

Image of operation in the case of A, B



---

## Setting of Demand Operation

By connecting the external contact input to the demand input of the outdoor unit external control adapter (optional), the power consumption of unit operation can be saved suppressing the compressor operating condition.

### A. When the demand operation is carried out by external instructions (with the use of the outdoor unit external control adapter).

- Set the "External low noise/Demand YES/NO setting" switch on the outdoor unit PCB to the "External low noise/Demand YES".  
(Set by Setting Mode 2)
- Set the "Demand 1 level setting " on the outdoor unit PCB, as the need arises.  
(During the demand level 1 instruction, the power consumption can be saved to 80 %, 70 % or 60 % of the rated value respectively.)

### B. When the continuous demand operation is carried out. (Use of the outdoor unit external control adapter is not required.)

- Set the "Continuous demand setting" on the outdoor unit PCB.
- If the "Continuous demand setting" is set to the "Continuous demand 1 fixing", set the "Demand 1 setting " on the outdoor unit PCB, as the need arises.  
(During the continuous demand level 1 operation, the power consumption can be saved to 80 %, 70 % or 60 % of the rated value respectively.)



**Image of operation in the case of A**

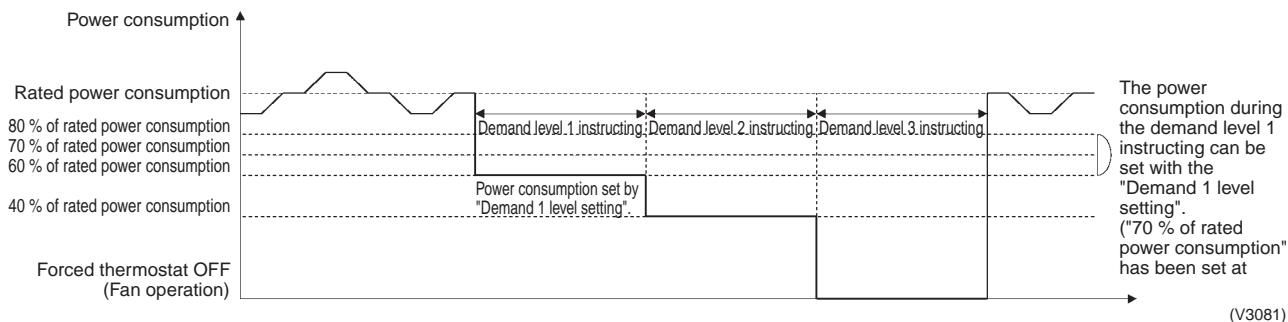

**Image of operation in the case of B**

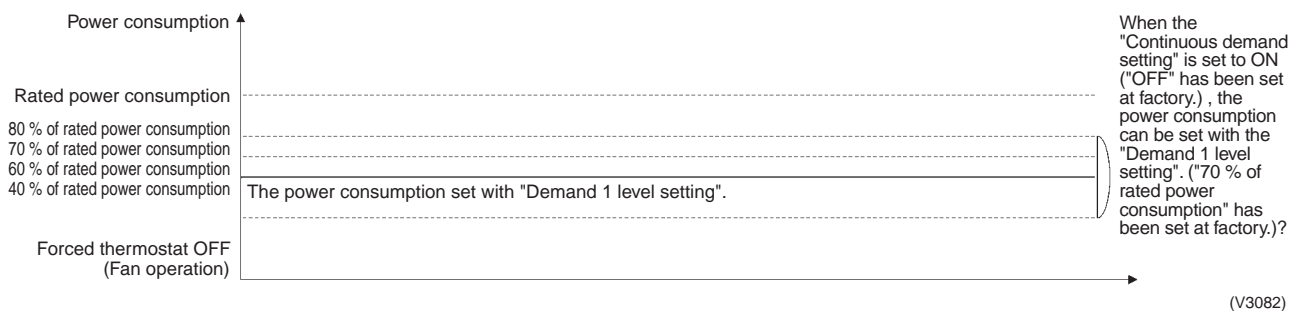

**Image of operation in the case of A and B**

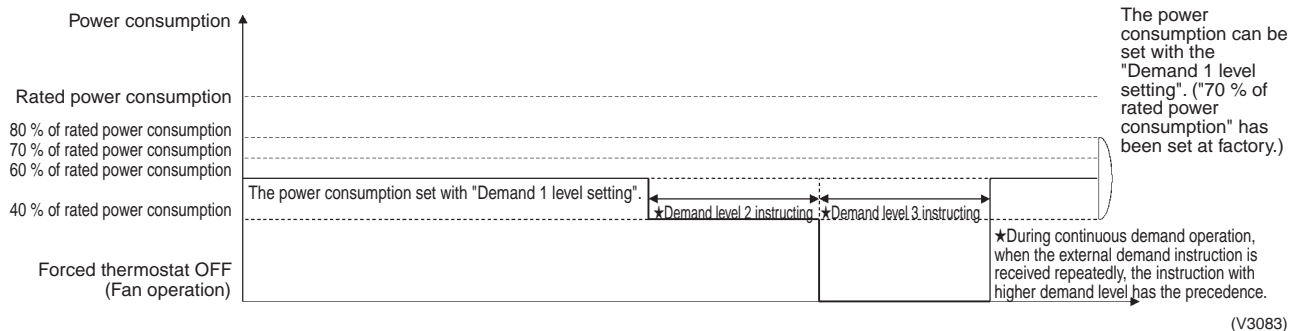

---

## Detailed Setting Procedure of Low Noise Operation and Demand Control

### 1. Setting mode 1 (H1P off)

- ① In setting mode 2, push the BS1 (MODE button) one time. → Setting mode 2 is entered and H1P lights.

During the setting mode 1 is displayed, "In low noise operation" and "In demand control" are displayed.

### 2. Setting mode 2 (H1P on)

- ① In setting 1, push and hold the BS1 (MODE button) for more than 5 seconds. → Setting mode 2 is entered and H1P lights.
- ② Push the BS2 (SET button) several times and match the LED display with the Setting No. you want.
- ③ Push the BS3 (RETURN button) one time, and the present setting content is displayed. → Push the BS2 (SET button) several times and match the LED display with the setting content (as shown below) you want.
- ④ Push the BS3 (RETURN button) two times. → Returns to ①.
- ⑤ Push the BS1 (MODE button) one time. → Returns to the setting mode 1 and turns H1P off.

Setting No.	Setting contents	① Setting No. indication							② Setting No. indication							Setting contents	③ Setting contents indication (Initial setting)											
		H1P	H2P	H3P	H4P	H5P	H6P	H7P	H1P	H2P	H3P	H4P	H5P	H6P	H7P		H1P	H2P	H3P	H4P	H5P	H6P	H7P					
22	Night-time low noise setting	○	●	●	●	●	●	●	○	●	○	●	○	○	●	OFF (Factory setting)	○	●	●	●	●	●	●	●	●			
																Mode 1	○	●	●	●	●	●	●	●	●	●	●	
																Mode 2	○	●	●	●	●	●	●	●	●	●	●	●
																Mode 3	○	●	●	●	●	●	●	●	●	●	●	●
25	External low noise setting	○	●	○	○	●	●	○	○	●	○	○	●	○	Mode 1	○	●	●	●	●	●	●	●	●	●			
															Mode 2 (Factory setting)	○	●	●	●	●	●	●	●	●	●	●		
															Mode 3	○	●	●	●	●	●	●	●	●	●	●	●	
26	Night-time low noise start setting	○	●	○	○	●	○	●	○	●	○	○	●	○	PM 8:00	○	●	●	●	●	●	●	●	●	●			
															PM 10:00 (Factory setting)	○	●	●	●	●	●	●	●	●	●	●		
															PM 0:00	○	●	●	●	●	●	●	●	●	●	●	●	
27	Night-time low noise end setting	○	●	○	○	●	○	○	○	●	○	○	○	○	AM 6:00	○	●	●	●	●	●	●	●	●	●			
															AM 7:00	○	●	●	●	●	●	●	●	●	●	●		
															AM 8:00 (Factory setting)	○	●	●	●	●	●	●	●	●	●	●	●	
29	Capacity precedence setting	○	●	○	○	○	●	○	○	●	○	○	●	○	Low noise precedence (Factory setting)	○	●	●	●	●	●	●	●	●				
															Capacity precedence	○	●	●	●	●	●	●	●	●	●	●		
30	Demand setting 1	○	●	○	○	○	○	○	○	●	○	○	○	○	●	60 % of rated power consumption	○	●	●	●	●	●	●	●	●	●		
																70 % of rated power consumption (Factory setting)	○	●	●	●	●	●	●	●	●	●	●	
																80 % of rated power consumption	○	●	●	●	●	●	●	●	●	●	●	●
32	Continuous demand setting	○	●	●	●	●	●	●	○	●	●	●	●	●	OFF (Factory setting)	○	●	●	●	●	●	●	●	●				
															Continuous demand 1 fixed	○	●	●	●	●	●	●	●	●	●	●		
12	External low noise / Demand setting	○	●	●	○	○	●	●	○	●	○	○	●	●	NO (Factory set)	○	●	●	●	●	●	●	○	●				
															YES	○	●	●	●	●	●	○	●					

Setting mode indication section

Setting No. indication section

Set contents indication section

### 3.2.4 Setting of Refrigerant Additional Charging Operation

When additional refrigerant is not charged all with outdoor unit in stop mode, operate the outdoor unit and charge the liquid refrigerant from the service port of liquid stop valve. The additional charging operation is activated by pushbutton switch on the outdoor unit PC board.

#### [Additional refrigerant charge total flow] [Additional refrigerant charge total flow]

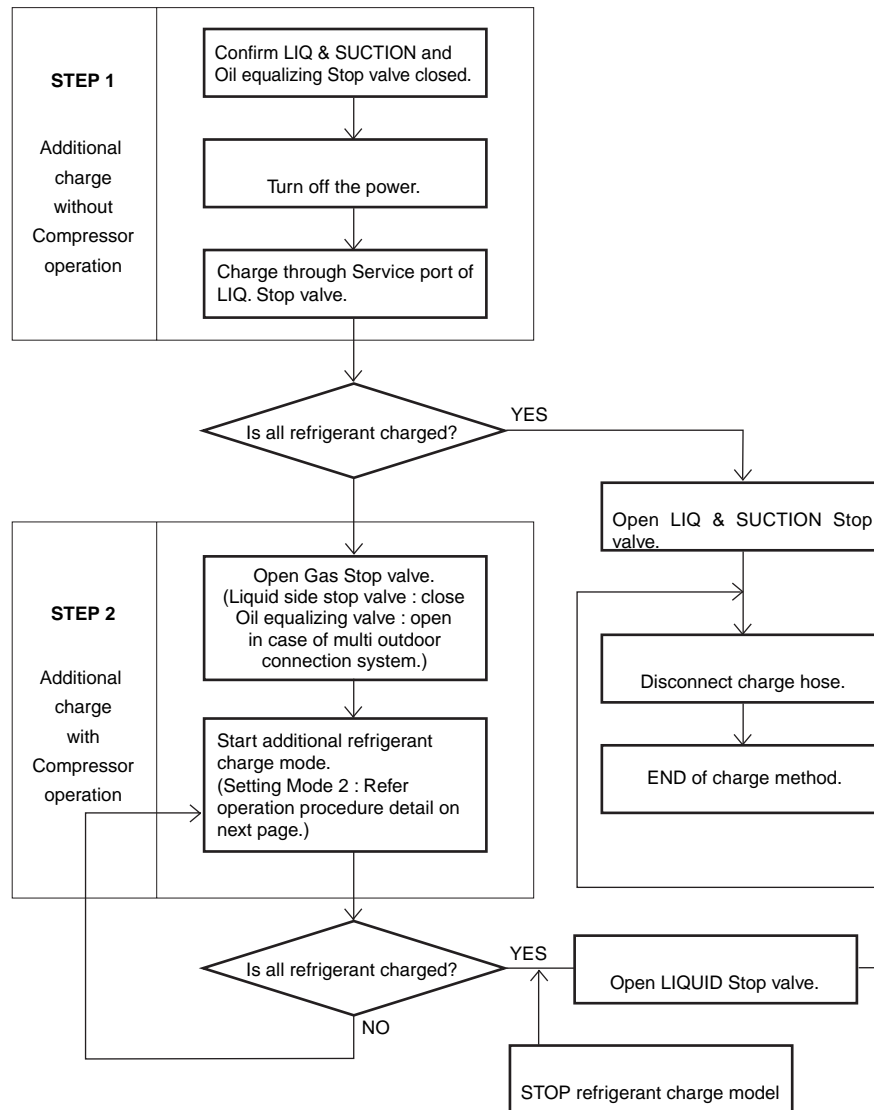

A/28001

**[Operation procedure detail]**

- ① After turning the respective remote switch of indoor and outdoor units off and charging the refrigerant, turn on the power of indoor and outdoor units.  
Do not fail to turn the power off and charge the refrigerant with outdoor unit in stop mode before adding the refrigerant following this procedure, otherwise resulting in trouble.
- ② Fully open the stop valve on the gas side and oil equalizing valve for multi outdoor connection, and do not fail to fully close the stop valve on the liquid side. (If the stop valve on the liquid side is open, the refrigerant cannot be charged.)
- ③ In **Setting mode 2** (H1P : ON) with outdoor unit in stop mode, Set "A Additional refrigerant charging operation" switch to ON to start the operation. (H2P turns to display TEST OPERATION (blinks), and "TEST OPERATION" and "IN CENTRALIZED CONTROL" are displayed on the remote controller.)
- ④ When the refrigerant is charged up to the specified amount, press the RETURN button (BS3) to stop charging.  
The charging operation is automatically stopped after operating for a maximum of about 30 minutes.  
If the charging is not complete within 30 minutes, set the A Additional refrigerant charging operation again to start charging. When the charging immediately stops even by restarting, the refrigerant is charged excessively. The refrigerant cannot be charged any more.
- ⑤ **Do not fail to fully open the stop valve on the liquid side** as soon as disconnecting the refrigerant charging hose.  
**(The piping may be burst due to the liquid sealing.)**

**[Operation state]**

- Compressor frequency : 210Hz
- Y1S, Y2S Solenoid valve : Open
- Outdoor unit fan : High pressure control
- Indoor unit expansion valve (All unit) : 1024 pulse
- Indoor unit fan : H tap

### 3.2.5 Setting of Refrigerant Recovery Mode

When carrying out the refrigerant collection on site, fully open the respective expansion valve of indoor and outdoor units

**[Operation procedure]**

- ① In **setting mode 2** with units in stop mode, set "B Refrigerant Recovery / Vacuuming mode" to ON. The respective expansion valve of indoor and outdoor units are fully opened. (H2P turns to display "TEST OPERATION" (blinks), "TEST OPERATION" and "IN CENTRALIZED CONTROL" are displayed on the remote controller, and the operation is prohibited.
- ② Collect the refrigerant using a refrigerant recovery unit. (See the instruction attached to the refrigerant recovery unit for more detail.)
- ③ Press Mode button "BS1" once and reset "Setting Mode 2".

### 3.2.6 Setting of Vacuuming Mode

In order to perform vacuuming operation at site, fully open the expansion valves of indoor and outdoor units to turn on some solenoid valves.

#### [Operating procedure]

- ① With **Setting Mode 2** while the unit stops, set (B) Refrigerant recovery / Vacuuming mode to ON. The expansion valves of indoor and outdoor units fully open and some of solenoid valves open.  
(H2P blinks to indicate the test operation, and the remote controller displays "Test Operation" and "In Centralized control", thus prohibiting operation.)  
After setting, do not cancel "Setting Mode 2" until completion of Vacuuming operation.
- ② Use the vacuum pump to perform vacuuming operation.
- ③ Press Mode button "BS1" once and reset "Setting Mode 2".

### 3.2.7 Check Operation

To prevent any trouble in the period of installation at site, the system is provided with a test operation mode enabling check for incorrect wiring, stop valve left in closed, coming out (or misplacing with suction pipe thermistor) of discharge pipe thermistor and judgment of piping length, refrigerant overcharging, and learning for the minimum opening degree of motorized valve.

#### CHECK OPERATION FUNCTION

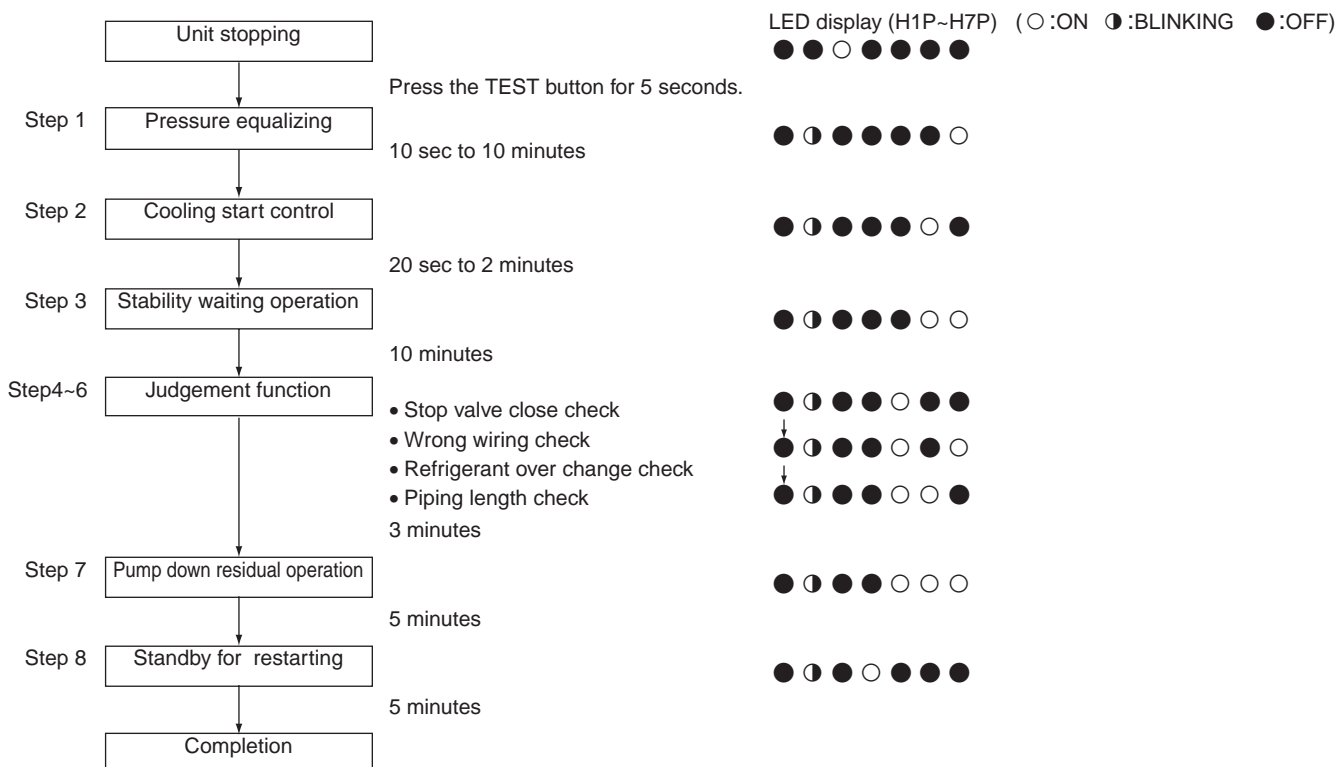

### 3.2.8 Power Transistor Check Operation

When the inverter system malfunctions (malfunction of inverter, INV compressor), to locate where the malfunction occurs, switching to the power transistor check mode of inverter in the service mode setting enables not to judge the position detection signal malfunction but to output waveform only during inverter operation. (The waveform can be checked by disconnecting the wiring of compressor.)



**Note:** Be sure to disconnect the compressor wiring when conducting the check operation mentioned above.

When the output voltage is approx. 50 V (10 Hz) and the voltage balance between phases U-V, V-W, W-U is within  $\pm 5\%$ , the inverter PCB is normal.



# Part 6

## Troubleshooting

1. Troubleshooting by Remote Controller .....	160
1.1 The INSPECTION / TEST Button.....	160
1.2 Self-diagnosis by Wired Remote Controller .....	161
1.3 Self-diagnosis by Wireless Remote Controller .....	162
1.4 Operation of The Remote Controller's Inspection / Test Operation Button .....	165
1.5 Remote Controller Service Mode .....	166
1.6 Remote Controller Self-Diagnosis Function .....	168
2. Troubleshooting by Indication on the Remote Controller .....	173
2.1 "R0" Indoor Unit: Error of External Protection Device .....	173
2.2 "R1" Indoor Unit: PC Board Defect.....	174
2.3 "R3" Indoor Unit: Malfunction of Drain Level Control System (S1L) .....	175
2.4 "R5" Indoor Unit: Fan Motor (M1F) Lock, Overload.....	177
2.5 "R7" Indoor Unit: Malfunction of Swing Flap Motor (MA) .....	178
2.6 "R9" Indoor Unit: Malfunction of Moving Part of Electronic Expansion Valve (20E).....	180
2.7 "RF" Indoor Unit: Drain Level above Limit.....	182
2.8 "RJ" Indoor Unit: Malfunction of Capacity Determination Device .....	183
2.9 "CY" Indoor Unit: Malfunction of Thermistor (R2T) for Heat Exchanger .....	184
2.10 "CS" Indoor Unit: Malfunction of Thermistor (R3T) for Gas Pipes.....	185
2.11 "CG" Indoor Unit: Malfunction of Thermistor (R1T) for Suction Air.....	186
2.12 "CU" Indoor Unit: Malfunction of Thermostat Sensor in Remote Controller .....	187
2.13 "E1" Outdoor Unit: PC Board Defect .....	188
2.14 "E3" Outdoor Unit: Actuation of High Pressure Switch .....	189
2.15 "E4" Outdoor Unit: Actuation of Low Pressure Sensor .....	190
2.16 "E5" Compressor Motor Lock .....	191
2.17 "E6" Compressor Motor Overcurrent/Lock .....	192
2.18 "E7" Malfunction of Outdoor Unit Fan Motor.....	193
2.19 "E9" Outdoor Unit: Malfunction of Moving Part of Electronic Expansion Valve (Y1E, Y2E).....	195
2.20 "F3" Outdoor Unit: Abnormal Discharge Pipe Temperature .....	197
2.21 "F5" Refrigerant Overcharged .....	198
2.22 "H7" Abnormal Outdoor Fan Motor Signal.....	199
2.23 "H9" Outdoor Unit: Malfunction of Thermistor for Outdoor Air (R1T).....	200
2.24 "J2" Current Sensor Malfunction.....	201
2.25 "J3" Outdoor Unit: Malfunction of Discharge Pipe Thermistor (R3, R31~33T) .....	202
2.26 "J5" Outdoor Unit: Malfunction of Thermistor (R2T) for Suction Pipe .....	203
2.27 "J6" Outdoor Unit: Malfunction of Thermistor (R4T) for Outdoor Unit Heat Exchanger .....	204
2.28 "JB" Malfunction of Oil Equalizing Pipe Thermistor (R7T).....	205
2.29 "J9" Malfunction of Receiver Gas Pipe Thermistor (R5T).....	206
2.30 "JR" Outdoor Unit: Malfunction of Discharge Pipe Pressure Sensor.....	207



2.31	“JL” Outdoor Unit: Malfunction of Suction Pipe Pressure Sensor .....	208
2.32	“L4” Outdoor Unit: Malfunction of Inverter Radiating Fin Temperature Rise .....	209
2.33	“L5” Outdoor Unit: Inverter Compressor Abnormal .....	210
2.34	“L8” Outdoor Unit: Inverter Current Abnormal .....	211
2.35	“L9” Outdoor Unit: Inverter Start up Error .....	212
2.36	“LC” Outdoor Unit: Malfunction of Transmission Between Inverter and Control PC Board .....	213
2.37	“P1” Outdoor Unit: Inverter Over-Ripple Protection .....	215
2.38	“P4” Outdoor Unit: Malfunction of Inverter Radiating Fin Temperature Rise Sensor .....	216
2.39	“UD” Low Pressure Drop Due to Refrigerant Shortage or Electronic Expansion Valve Failure .....	217
2.40	“U1” Reverse Phase, Open Phase .....	218
2.41	“U2” Power Supply Insufficient or Instantaneous Failure .....	219
2.42	“U3” Check Operation not executed .....	221
2.43	“U4” Malfunction of Transmission Between Indoor Units .....	222
2.44	“U5” Malfunction of Transmission Between Remote Controller and Indoor Unit .....	224
2.45	“U7” Malfunction of Transmission Between Outdoor Units .....	225
2.46	“UB” Malfunction of Transmission Between Master and Slave Remote Controllers .....	227
2.47	“UG” Malfunction of Transmission Between Indoor and Outdoor Units in the Same System .....	228
2.48	“UR” Excessive Number of Indoor Units .....	230
2.49	“UC” Address Duplication of Central Remote Controller .....	231
2.50	“UE” Malfunction of Transmission Between Central Remote Controller and Indoor Unit .....	232
2.51	“UF” Refrigerant System not Set, Incompatible Wiring/Piping .....	234
2.52	“UH” Malfunction of System, Refrigerant System Address Undefined .....	235
3.	Troubleshooting (OP: Central Remote Controller) .....	236
3.1	“UE” Malfunction of Transmission Between Central Remote Controller and Indoor Unit .....	236
3.2	“M1” PC Board Defect .....	237
3.3	“MB” Malfunction of Transmission Between Optional Controllers for Centralized Control .....	238
3.4	“MR” Improper Combination of Optional Controllers for Centralized Control .....	239
3.5	“MC” Address Duplication, Improper Setting .....	241
4.	Troubleshooting (OP: Schedule Timer) .....	242
4.1	“UE” Malfunction of Transmission Between Central Remote Controller and Indoor Unit .....	242
4.2	“M1” PC Board Defect .....	244
4.3	“MB” Malfunction of Transmission Between Optional Controllers for Centralized Control .....	245
4.4	“MR” Improper Combination of Optional Controllers for Centralized Control .....	246
4.5	“MC” Address Duplication, Improper Setting .....	248
5.	Troubleshooting (OP: Unified ON/OFF Controller) .....	249
5.1	Operation Lamp Blinks .....	249

5.2 Display “Under Host Computer Integrate Control” Blinks (Repeats Single Blink) .....	251
5.3 Display “Under Host Computer Integrate Control” Blinks (Repeats Double Blink) .....	254

# 1. Troubleshooting by Remote Controller

## 1.1 The INSPECTION / TEST Button

The following modes can be selected by using the [Inspection/Test Operation] button on the remote control.

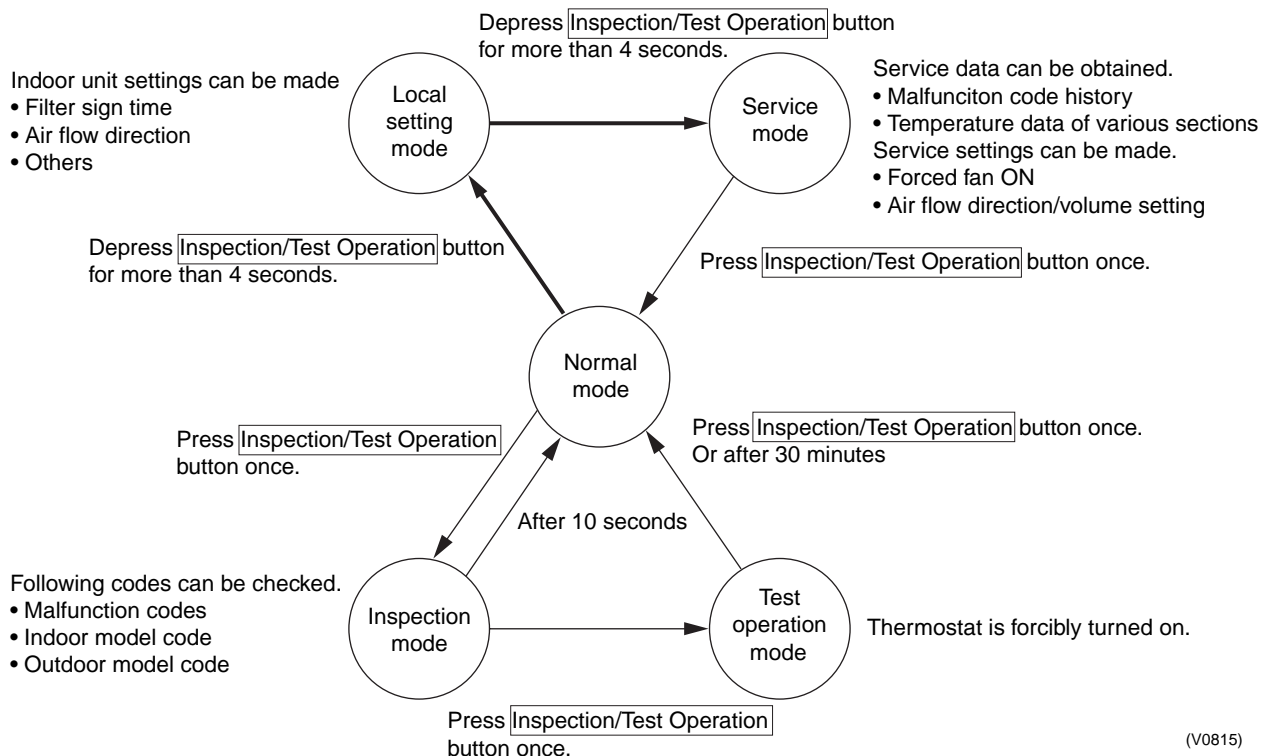

(V0815)

## 1.2 Self-diagnosis by Wired Remote Controller

### Explanation

If operation stops due to malfunction, the remote controller's operation LED blinks, and malfunction code is displayed. (Even if stop operation is carried out, malfunction contents are displayed when the inspection mode is entered.) The malfunction code enables you to tell what kind of malfunction caused operation to stop. See page 168 for malfunction code and malfunction contents.

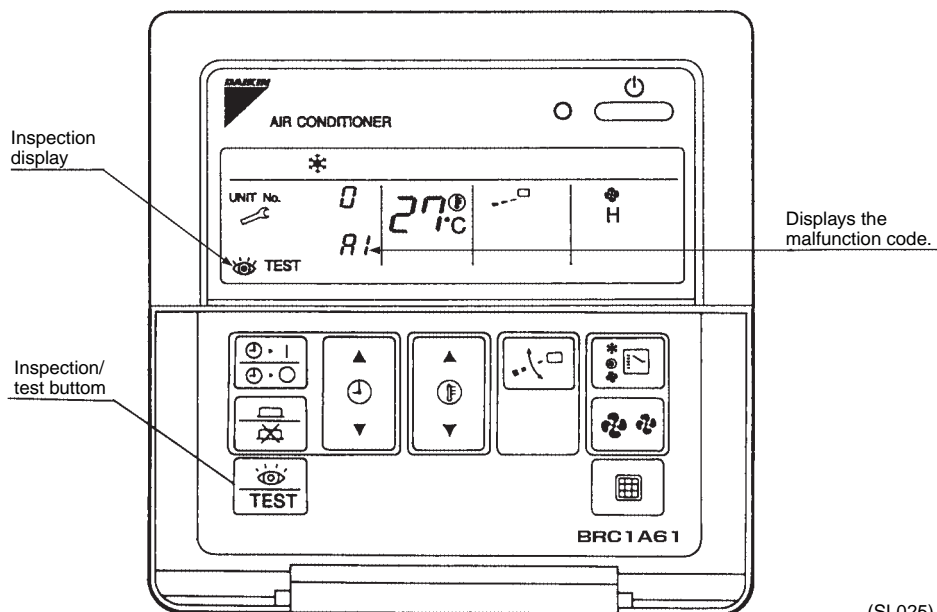

(SL025)

## 1.3 Self-diagnosis by Wireless Remote Controller

### In the Case of BRC7C ~ Type

If equipment stops due to a malfunction, the operation indicating LED on the light reception section flashes.

The malfunction code can be determined by following the procedure described below. (The malfunction code is displayed when an operation error has occurred. In normal condition, the malfunction code of the last problem is displayed.)

1. Press the INSPECTION/TEST button to select "Inspection."  
The equipment enters the inspection mode. The "Unit" indication lights and the Unit No. display shows flashing "0" indication.
2. Set the Unit No.  
Press the UP or DOWN button and change the Unit No. display until the buzzer (\*1) is generated from the indoor unit.  
\*1 Number of beeps  
**3 short beeps** : Conduct all of the following operations.  
**1 short beep** : Conduct steps 3 and 4.  
Continue the operation in step 4 until a buzzer remains ON. The continuous buzzer indicates that the malfunction code is confirmed.  
**Continuous beep** : No abnormality.
3. Press the MODE selector button.  
The left "0" (upper digit) indication of the malfunction code flashes.
4. Malfunction code upper digit diagnosis  
Press the UP or DOWN button and change the malfunction code upper digit until the malfunction code matching buzzer (\*2) is generated.

- The upper digit of the code changes as shown below when the UP and DOWN buttons are pressed.



\*2 Number of beeps

**Continuous beep** : Both upper and lower digits matched. (Malfunction code confirmed)

**2 short beeps** : Upper digit matched.

**1 short beep** : Lower digit matched.

5. Press the MODE selector button.  
The right "0" (lower digit) indication of the malfunction code flashes.
6. Malfunction code lower digit diagnosis  
Press the UP or DOWN button and change the malfunction code lower digit until the continuous malfunction code matching buzzer (\*2) is generated.

- The lower digit of the code changes as shown below when the UP and DOWN buttons are pressed.

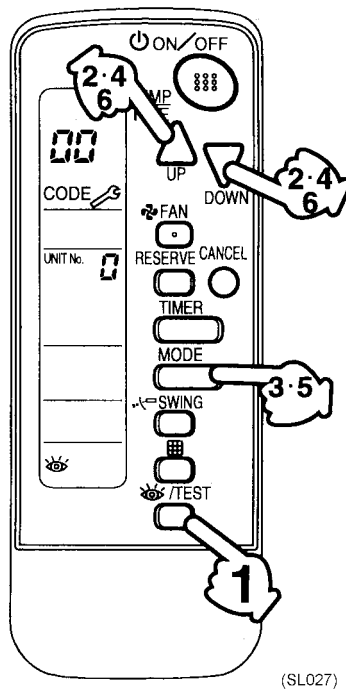

Normal status  
Enters inspection mode from normal status when the INSPECTION/TEST button is pressed.

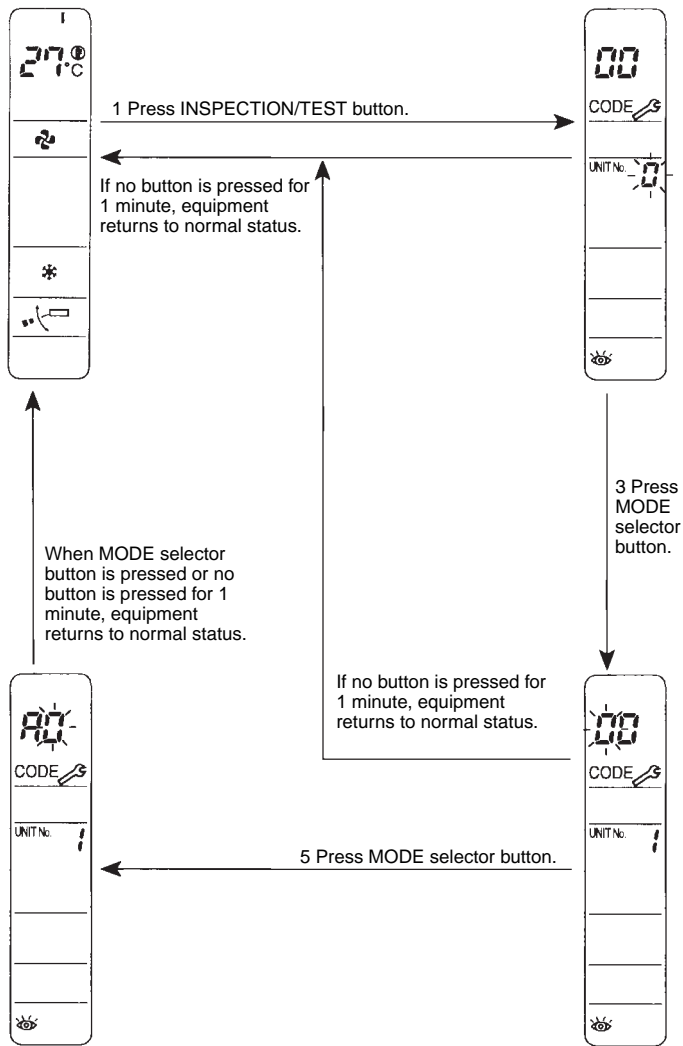

(SF008)

# 1.4 Operation of The Remote Controller's Inspection / Test Operation Button

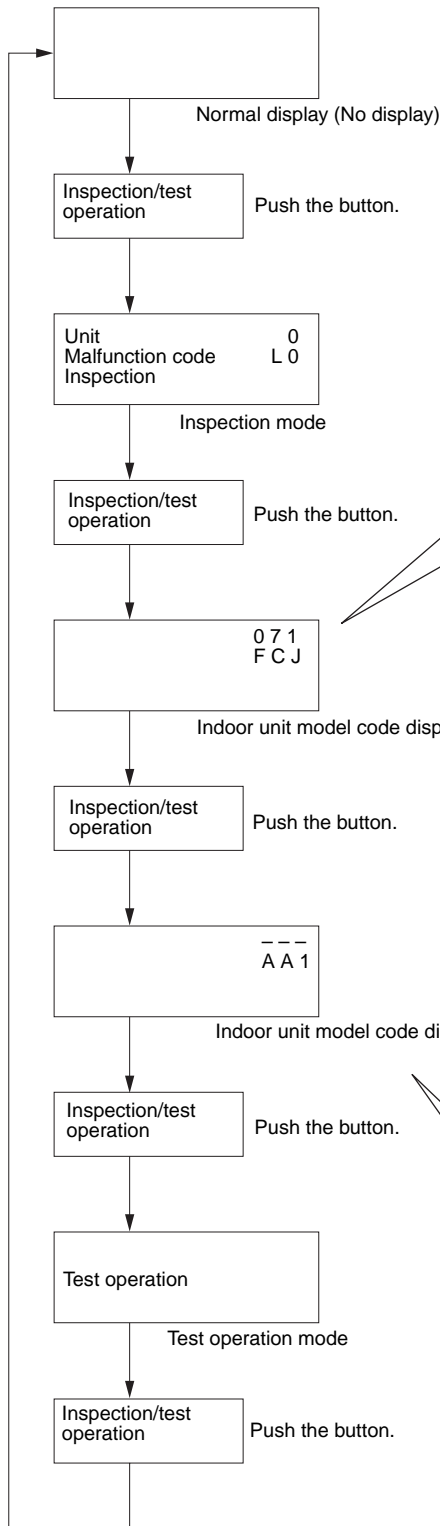

Unit 0  
Malfunction code L 0  
Inspection

Malfunction code blinks when a malfunction occurs.

0 7 1... Capacity code  
F... Indoor unit system code  
C... Indoor unit type code  
J... Progression code

Example of capacity code display

Example model	Display
FXCQ25	028
FXFQ63	071

Indoor unit system code

Display	Product classification	System classification
1	VRV system	(VAV indoor unit)
2	VRV system	Outdoor air processing unit
F	VRV system	Standard indoor unit
H	VRV system	New ceiling suspended cassette

Indoor unit type code

Display	Type	Model
A	Wall mounted	FXAQ
C	Double flow	FXCQ
E	Corner	FXKQ
F	Multi flow	FXFQ
H	Ceiling suspended	FXHQ
J	Built-in	FXSQ
L	Floor standing	FXLQ
P	Concealed ceiling duct	FXMQ
L	Concealed floor standing type	FXNQ
6	Multi flow 600x600	FXZQ
3	Slim Ceiling mounted duct	FXDQ
5	New ceiling suspended cassette	FXUQ

Outdoor model code

Display	Type	Model
A A 1	VRV System Inverter K Series	RSXYP
A A 3	R407C VRV PLUS Series	RXYP
A 9 2	VRV Heat Recovery Series	RSEYP
A A 5	High COP type R407C L Series	RSXYP-L
A A A	VRV II	RXYQ-M

(V2775)



# 1.5 Remote Controller Service Mode

## How to Enter the Service Mode

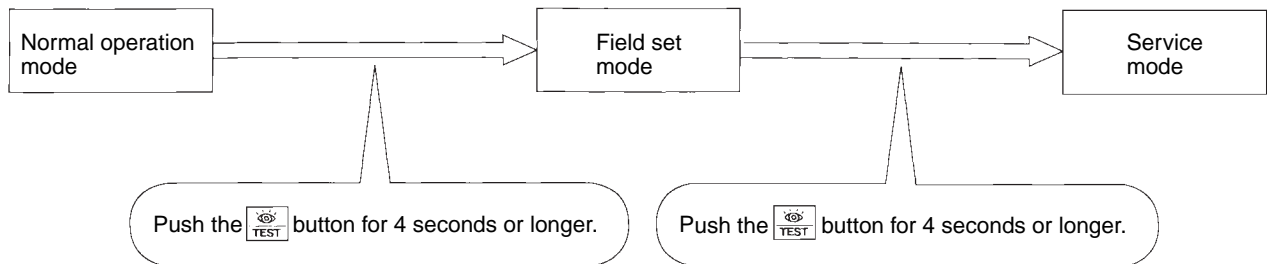

(VFO020)

### Service Mode Operation Method

**1. Select the mode No.**

Set the desired mode No. with the button.  
(For wireless remote controller, Mode 43 only can be set.)

**2. Select the unit No. (For group control only)**

Select the indoor unit No. to be set with the time mode . (For wireless remote controller, button.)

**3. Make the settings required for each mode. (Modes 41, 44, 45)**

In case of Mode 44, 45, push button to be able to change setting before setting work. (LCD "code" blinks.)









For details, refer to the table in next page.

**4. Define the setting contents. (Modes 44, 45)**

Define by pushing the timer button.  
After defining, LCD "code" changes blinking to ON.

**5. Return to the normal operation mode.**

Push the button one time.

Mode No	Function	Contents and operation method	Remote controller display example
40	Malfunction hysteresis display	<p>Display malfunction hysteresis.</p> <p>The history No. can be changed with the  button.</p>	<p>Unit 1</p> <p>Malfunction code <b>40</b></p> <p>2-U4</p> <p>Malfunction code</p> <p>Hystory No: 1 - 9</p> <p>1: Latest</p> <p>(VE007)</p>
41	Display of sensor and address data	<p>Display various types of data.</p> <p>Select the data to be displayed with the  button. Sensor data</p> <p>0: Thermostat sensor in remote controller. 1: Suction 2: Liquid pipe 3: Gas pipe</p> <p>Address data 4: Indoor unit address 5: Outdoor unit address 6: BS unit address 7: Zone control address 8: Cool/heat group address 9: Demand / low noise address</p>	<p>Sensor data display</p> <p>Unit No. Sensor type</p> <p>1 1</p> <p>2 7</p> <p>Temperature °C</p> <p>Address display</p> <p>Unit No. Address type</p> <p>1 8</p> <p>1</p> <p>Address</p> <p>(VE008)</p>
43	Forced fan ON	<p>Manually turn the fan ON by each unit. (When you want to search for the unit No.)</p> <p>By selecting the unit No. with the  button, you can turn the fan of each indoor unit on (forced ON) individually.</p>	<p>Unit 1</p> <p><b>43</b></p> <p>(VE009)</p>
44	Individual setting	<p>Set the fan speed and air flow direction by each unit</p> <p>Select the unit No. with the time mode  button. Set the fan speed with the  button.</p> <p>Set the air flow direction with the  button.</p>	<p>Unit 1</p> <p>Code <b>44</b></p> <p>1 3</p> <p>Fan speed 1: Low 3: High</p> <p>Air flow direction P0 - P4</p> <p>(VE010)</p>
45	Unit No. transfer	<p>Transfer unit No.</p> <p>Select the unit No. with the  button. Set the unit No. after transfer with the  button.</p>	<p>Present unit No.</p> <p>Unit 1</p> <p>Code <b>45</b></p> <p>0 2</p> <p>Unit No. after transfer</p> <p>(VE011)</p>
46	This function is not used by VRV II R410A Heat Pump 50Hz.		
47			

## 1.6 Remote Controller Self-Diagnosis Function

The remote controller switches are equipped with a self diagnosis function so that more appropriate maintenance can be carried out. If a malfunction occurs during operation, the operation lamp, malfunction code and display of malfunctioning unit No. let you know the contents and location of the malfunction.

When there is a stop due to malfunction, the contents of the malfunction given below can be diagnosed by a combination of operation lamp, INSPECTION display of the liquid crystal display and display of malfunction code. It also lets you know the unit No. during group control.

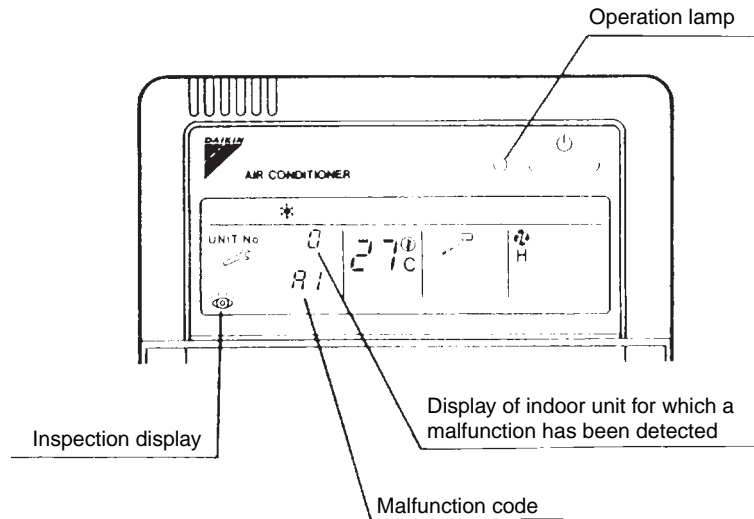

(VL050)

	Malfunction code	Operation lamp	Inspection display	Unit No.	Malfunction contents	Page Referred
Indoor Unit	A0	●	●	●	Error of external protection device	173
	A1	●	●	●	PC board defect, E <sup>2</sup> PROM defect	174
	A3	●	●	●	Malfunction of drain level control system (33H)	175
	A6	●	●	●	Fan motor (MF) lock, overload	177
	A7	○	●	●	Malfunction of swing flap motor (MA)	178
	A9	●	●	●	Malfunction of moving part of electronic expansion valve (20E)	180
	AF	○	●	●	Drain level about limit	182
	AH	○	●	●	Malfunction of air filter maintenance	—
	AJ	●	●	●	Malfunction of capacity setting	183
	C4	●	●	●	Malfunction of thermistor (R2T) for heat exchange (loose connection, disconnection, short circuit, failure)	184
	C5	●	●	●	Malfunction of thermistor (R3T) for gas pipes (loose connection, disconnection, short circuit, failure)	185
	C9	●	●	●	Malfunction of thermistor (R1T) for air inlet (loose connection, disconnection, short circuit, failure)	186
	CJ	○	○	○	Malfunction of thermostat sensor in remote controller	187
	Outdoor Unit	E1	●	●	●	PC board defect
E3		●	●	●	Actuation of high pressure switch	189
E4		●	●	●	Actuation of low pressure sensor	190
E5		●	●	●	Compressor motor lock	191
E6		●	●	●	Standard compressor lock or over current	192
E7		●	●	●	Malfunction of outdoor unit fan motor	193
E9		●	●	●	Malfunction of moving part of electronic expansion valve (Y1E~3E)	195
F3		●	●	●	Abnormal discharge pipe temperature	197
F6		●	●	●	Refrigerant overcharged	198
H3		○	●	●	Malfunction of High pressure switch	—
H4		●	●	●	Malfunction of Low pressure switch	—
H7		●	●	●	Abnormal outdoor fan motor signal	199
H9		●	●	●	Malfunction of thermistor (R1T) for outdoor air (loose connection, disconnection, short circuit, failure)	200
J2		●	●	●	Current sensor malfunction	201
J3		●	●	●	Malfunction of discharge pipe thermistor (R31~33T) (loose connection, disconnection, short circuit, failure)	202
J5		●	●	●	Malfunction of thermistor (R2T) for suction pipe (loose connection, disconnection, short circuit, failure)	203
Outdoor Unit		J6	●	●	●	Malfunction of thermistor (R4T) for heat exchanger (loose connection, disconnection, short circuit, failure)
	J7	●	●	●	Malfunction of header thermistor	—
	J8	●	●	●	Malfunction of thermistor (R7T) for oil equalizing pipe. (loose connection, disconnection, short circuit, failure)	205
	J9	●	●	●	Malfunction of receiver gas pipe thermistor (R5T)	206
	JA	●	●	●	Malfunction of discharge pipe pressure sensor	207
	JC	●	●	●	Malfunction of suction pipe pressure sensor	208
	L0	●	●	●	Inverter system error	—
	L4	●	●	●	Malfunction of inverter radiating fin temperature rise	209
	L5	●	●	●	Inverter compressor motor grounding, short circuit	210
	L6	●	●	●	Compressor motor coil grounding on short circuit	—
	L8	●	●	●	Inverter current abnormal	211
L9	●	●	●	Inverter start up error	212	

	Malfunction code	Operation lamp	Inspection display	Unit No.	Malfunction contents	Page Referred
Outdoor Unit	LA	●	●	●	Malfunction of power unit	—
	LC	●	●	●	Malfunction of transmission between inverter and control PC board	213
	P1	●	●	●	Inverter over-ripple protection	215
	P4	●	●	●	Malfunction of inverter radiating fin temperature rise sensor	216
System	U0	○	●	●	Low pressure drop due to refrigerant shortage or electronic expansion valve failure	217
	U1	●	●	●	Reverse phase / open phase	218
	U2	●	●	●	Power supply insufficient or instantaneous failure	219
	U3	●	●	●	Check operation is not conducted.	221
	U4	●	●	●	Malfunction of transmission between indoor and outdoor units	222
	U5	●	●	●	Malfunction of transmission between remote controller and indoor unit	224
	U5	●	○	●	Failure of remote controller PC board or setting during control by remote controller	224
	U7	●	●	●	Malfunction of transmission between outdoor units	225
	U8	●	●	●	Malfunction of transmission between master and slave remote controllers (malfunction of slave remote controller)	227
	U9	●	●	●	Malfunction of transmission between indoor unit and outdoor unit in the same system	228
	UA	●	●	●	Excessive number of indoor units etc.	230
	UC	○	○	○	Address duplication of central remote controller	231
	UE	●	●	●	Malfunction of transmission between central remote controller and indoor unit	232 236 242
	UF	●	●	●	Refrigerant system not set, incompatible wiring / piping	234
	UH	●	●	●	Malfunction of system, refrigerant system address undefined	235
Centralized Control and Schedule Timer	M1	○ or ●	●	●	PC board defect	237 244
	M8	○ or ●	●	●	Malfunction of transmission between optional controllers for centralized control	238 245
	MA	○ or ●	●	●	Improper combination of optional controllers for centralized control	239 246
	MC	○ or ●	●	●	Address duplication, improper setting	241 248
Heat Reclaim Ventilation	64	○	●	●	Indoor unit's air thermistor error	—
	65	○	●	●	Outside air thermistor error	—
	68	○	●	●		—
	6A	○	●	●	Damper system alarm	—
	6A	●	●	●	Damper system + thermistor error	—
	6F	○	●	●	Malfunction of simple remote controller	—
	6H	○	●	●	Malfunction of door switch or connector	—
94	●	●	●	Internal transmission error	—	

 The system operates for malfunction codes indicated in black squares, however, be sure to check and repair.

## Malfunction code indication by outdoor unit PCB

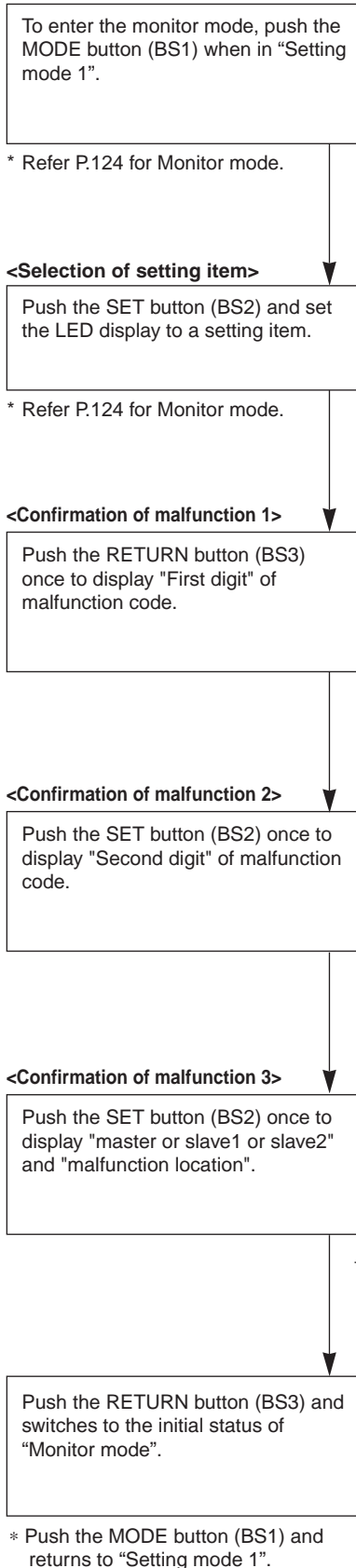

Detail description on next page.

Contents of malfunction		Malfunction code
Abnormal discharge pressure	HPS activated	E3
Abnormal suction pressure	Abnormal Pe	E4
Compressor lock	Detection of INV compressor lock	E5
Activation of OC	Detection of STD1 compressor lock	E6
	Detection of STD2 compressor lock	
Over load, over current, abnormal lock of outdoor unit fan motor	Instantaneous over current of DC fan motor	E7
	Detection of DC fan motor lock	
Malfunction of electronic expansion valve	EV1	E9
	EV2	
	EV3	
Abnormal position signal of outdoor unit fan motor	Abnormal position signal of DC fan motor	H7
Faulty sensor of outdoor air temperature	Faulty Ta sensor	H9
Faulty sensor of heat storage unit		HC
Abnormality in water system of heat storage unit		HJ
Transmission error between heat storage unit and controller		HF
Abnormal discharge pipe temperature	Abnormal Td	F3
Abnormal heat exchanger temperature	Refrigerant over charge	F6
Faulty current sensor	Faulty CT1 sensor	J2
	Faulty CT2 sensor	
Faulty sensor of discharge pipe temperature	Faulty Tdi sensor	J3
	Faulty Tds1 sensor	
	Faulty Tds2 sensor	
Faulty sensor of suction pipe temperature	Faulty Ts sensor	J5
Faulty sensor of heat exchanger temperature	Faulty Tb sensor	J6
Faulty sensor of receiver temperature	Faulty Tl sensor	J7
Faulty sensor of oil pressure equalizing pipe temperature	Faulty To sensor	J8
Faulty sensor of subcool heat exchanger temperature	Faulty Tsh sensor	J9
Faulty sensor of discharge pressure	Faulty Pc sensor	JA
Faulty sensor of suction pressure	Faulty Pe sensor	JC
Inverter radiation fin temperature rising	Over heating of inverter radiation fin temperature	L4
DC output over current	Inverter instantaneous over current	L5
Electronic thermal switch	Electronic thermal switch 1	L8
	Electronic thermal switch 2	
	Out-of-step	
	Speed down after startup	
	Lightening detection	
Stall prevention (Limit time)	Stall prevention (Current increasing)	L9
	Stall prevention (Faulty startup)	
	Abnormal wave form in startup	
	Out-of-step	
Transmission error between inverter and outdoor unit	Inverter transmission error	LC
Open phase/Power supply imbalance	Imbalance of inverter power supply voltage	P1
Faulty temperature sensor inside switch box	Faulty thermistor of inverter box	P3
Faulty temperature sensor of inverter radiation fin	Faulty thermistor of inverter fin	P4
Incorrect combination of inverter and fan driver	Incorrect combination of inverter and fan driver	PJ
Gas shortage	Gas shortage alarm	U0
Reverse phase	Reverse phase error	U1
Abnormal power supply voltage	Insufficient inverter voltage	U2
	Inverter open phase (phase T)	
	Charging error of capacitor in inverter main circuit	
No implementation of test-run		U3
Transmission error between indoor and outdoor unit	I/O transmission error	U4
Transmission error between outdoor units, transmission error between thermal storage units, duplication of IC address	O/O transmission error	U7
Transmission error of other system	Indoor unit system malfunction in other system or other unit of own system	U9
Erroneous on-site setting	Abnormal connection with excessive number of indoor units	UA
	Conflict of refrigerant type in indoor units	
Faulty system function	Incorrect wiring (Auto address error)	UH
Transmission error in accessory devices, conflict in wiring and piping, no setting for system	Malfunction of multi level converter, abnormality in conflict check	UJ
		UF

Malfunction code	Confirmation of malfunction 1							Confirmation of malfunction 2							Confirmation of malfunction 3							
	LED1	LED2	LED3	LED4	LED5	LED6	LED7	LED1	LED2	LED3	LED4	LED5	LED6	LED7	LED1	LED2	LED3	LED4	LED5	LED6	LED7	
E3	○	●	○	●	●	○	○	○	○	●	●	○	○	○	○	○	○	○	○	○	○	○
E4	○	○	○	○	○	○	○	○	○	○	○	○	○	○	○	○	○	○	○	○	○	○
E5	○	○	○	○	○	○	○	○	○	○	○	○	○	○	○	○	○	○	○	○	○	○
E6	○	○	○	○	○	○	○	○	○	○	○	○	○	○	○	○	○	○	○	○	○	○
E7	○	○	○	○	○	○	○	○	○	○	○	○	○	○	○	○	○	○	○	○	○	○
E9	○	○	○	○	○	○	○	○	○	○	○	○	○	○	○	○	○	○	○	○	○	○
H7	○	●	○	●	○	●	●	○	○	○	○	○	○	○	○	○	○	○	○	○	○	○
H9	○	○	○	○	○	○	○	○	○	○	○	○	○	○	○	○	○	○	○	○	○	○
HC	○	○	○	○	○	○	○	○	○	○	○	○	○	○	○	○	○	○	○	○	○	○
HJ	○	○	○	○	○	○	○	○	○	○	○	○	○	○	○	○	○	○	○	○	○	○
HF	○	○	○	○	○	○	○	○	○	○	○	○	○	○	○	○	○	○	○	○	○	○
F3	○	●	○	●	○	●	○	○	○	○	○	○	○	○	○	○	○	○	○	○	○	○
F6	○	○	○	○	○	○	○	○	○	○	○	○	○	○	○	○	○	○	○	○	○	○
J2	○	●	○	●	○	○	○	○	○	○	○	○	○	○	○	○	○	○	○	○	○	○
J3	○	○	○	○	○	○	○	○	○	○	○	○	○	○	○	○	○	○	○	○	○	○
J5	○	○	○	○	○	○	○	○	○	○	○	○	○	○	○	○	○	○	○	○	○	○
J6	○	○	○	○	○	○	○	○	○	○	○	○	○	○	○	○	○	○	○	○	○	○
J7	○	○	○	○	○	○	○	○	○	○	○	○	○	○	○	○	○	○	○	○	○	○
J8	○	○	○	○	○	○	○	○	○	○	○	○	○	○	○	○	○	○	○	○	○	○
J9	○	○	○	○	○	○	○	○	○	○	○	○	○	○	○	○	○	○	○	○	○	○
JA	○	○	○	○	○	○	○	○	○	○	○	○	○	○	○	○	○	○	○	○	○	○
JC	○	○	○	○	○	○	○	○	○	○	○	○	○	○	○	○	○	○	○	○	○	○
L4	○	○	○	○	○	○	○	○	○	○	○	○	○	○	○	○	○	○	○	○	○	○
L5	○	○	○	○	○	○	○	○	○	○	○	○	○	○	○	○	○	○	○	○	○	○
L8	○	○	○	○	○	○	○	○	○	○	○	○	○	○	○	○	○	○	○	○	○	○
L9	○	○	○	○	○	○	○	○	○	○	○	○	○	○	○	○	○	○	○	○	○	○
LC	○	○	○	○	○	○	○	○	○	○	○	○	○	○	○	○	○	○	○	○	○	○
P1	○	●	○	○	●	●	●	○	○	○	○	○	○	○	○	○	○	○	○	○	○	○
P3	○	○	○	○	○	○	○	○	○	○	○	○	○	○	○	○	○	○	○	○	○	○
P4	○	○	○	○	○	○	○	○	○	○	○	○	○	○	○	○	○	○	○	○	○	○
PJ	○	○	○	○	○	○	○	○	○	○	○	○	○	○	○	○	○	○	○	○	○	○
U0	○	●	○	○	●	●	○	○	○	○	○	○	○	○	○	○	○	○	○	○	○	○
U1	○	○	○	○	○	○	○	○	○	○	○	○	○	○	○	○	○	○	○	○	○	○
U2	○	○	○	○	○	○	○	○	○	○	○	○	○	○	○	○	○	○	○	○	○	○
U3	○	○	○	○	○	○	○	○	○	○	○	○	○	○	○	○	○	○	○	○	○	○
U4	○	○	○	○	○	○	○	○	○	○	○	○	○	○	○	○	○	○	○	○	○	○
U7	○	○	○	○	○	○	○	○	○	○	○	○	○	○	○	○	○	○	○	○	○	○
U9	○	○	○	○	○	○	○	○	○	○	○	○	○	○	○	○	○	○	○	○	○	○
UA	○	○	○	○	○	○	○	○	○	○	○	○	○	○	○	○	○	○	○	○	○	○
UH	○	○	○	○	○	○	○	○	○	○	○	○	○	○	○	○	○	○	○	○	○	○
UJ	○	○	○	○	○	○	○	○	○	○	○	○	○	○	○	○	○	○	○	○	○	○
UF	○	○	○	○	○	○	○	○	○	○	○	○	○	○	○	○	○	○	○	○	○	○

○ : ON  
 ○ (with dot) : Blink  
 ● : OFF

Malfunction code 1st digit display section

○ : ON  
 ○ (with dot) : Blink  
 ● : OFF

Malfunction code 2nd digit display section

Master ● ● Malfunction location  
 Slave 1 ● ○  
 Slave 2 ○ ●

## 2. Troubleshooting by Indication on the Remote Controller

### 2.1 "AO" Indoor Unit: Error of External Protection Device

Remote  
Controller  
Display

AO

Applicable  
Models

All indoor unit models

Method of  
Malfunction  
Detection

Malfunction  
Decision  
Conditions

Supposed  
Causes

- Actuation of external protection device
- Improper field set
- Defect of indoor unit PC board

Troubleshooting



**Caution**

Be sure to turn off power switch before connect or disconnect connector, or parts damage may be occurred.

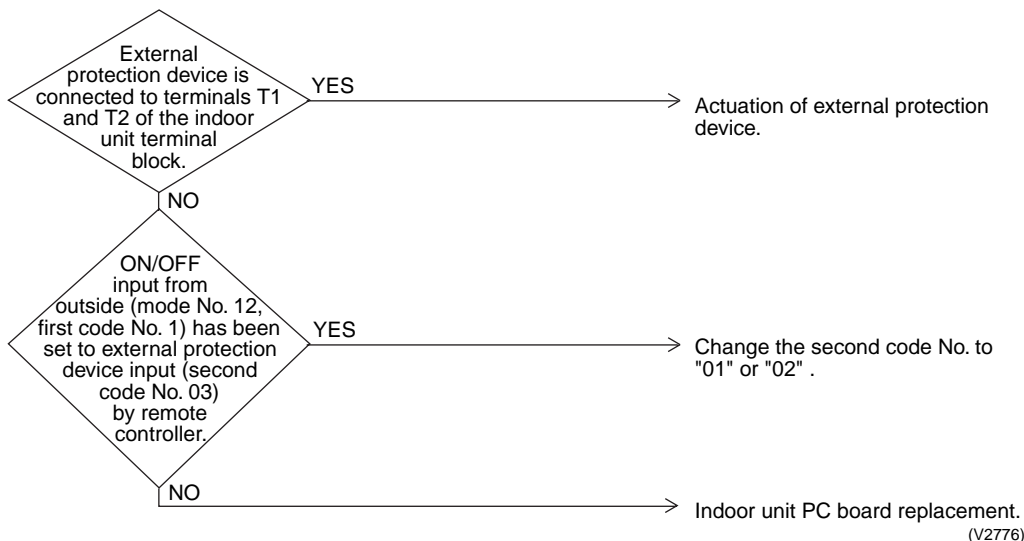



## 2.2 “A1” Indoor Unit: PC Board Defect

Remote  
Controller  
Display

A1

Applicable  
Models

All indoor unit models

Method of  
Malfunction  
Detection

Check data from E<sup>2</sup>PROM.

Malfunction  
Decision  
Conditions

When data could not be correctly received from the E<sup>2</sup>PROM  
E<sup>2</sup>PROM : Type of nonvolatile memory. Maintains memory contents even when the power supply is turned off.

Supposed  
Causes

- Defect of indoor unit PC board

Troubleshooting



**Caution**

Be sure to turn off power switch before connect or disconnect connector, or parts damage may be occurred.

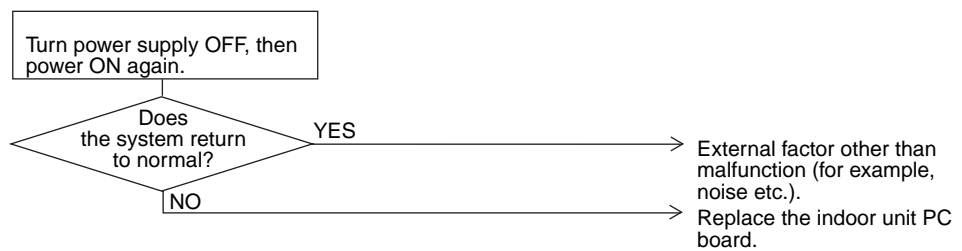

(V2777)

## 2.3 “R3” Indoor Unit: Malfunction of Drain Level Control System (S1L)

<b>Remote Controller Display</b>	<i>R3</i>
<b>Applicable Models</b>	FXCQ, FXFQ, FXZQ, FXSQ, FXKQ, FXDQ, FXMQ, FXUQ, FXHQ (Option), FXMQ200,250M (Option), FXAQ (Option), FXMQ-MF (Option)
<b>Method of Malfunction Detection</b>	By float switch OFF detection
<b>Malfunction Decision Conditions</b>	When rise of water level is not a condition and the float switch goes OFF.
<b>Supposed Causes</b>	<ul style="list-style-type: none"> <li>■ 220~240V power supply is not provided</li> <li>■ Defect of float switch or short circuit connector</li> <li>■ Defect of drain pump</li> <li>■ Drain clogging, upward slope, etc.</li> <li>■ Defect of indoor unit PC board</li> <li>■ Loose connection of connector</li> </ul>

Troubleshooting



**Caution**

Be sure to turn off power switch before connect or disconnect connector, or parts damage may be occurred.

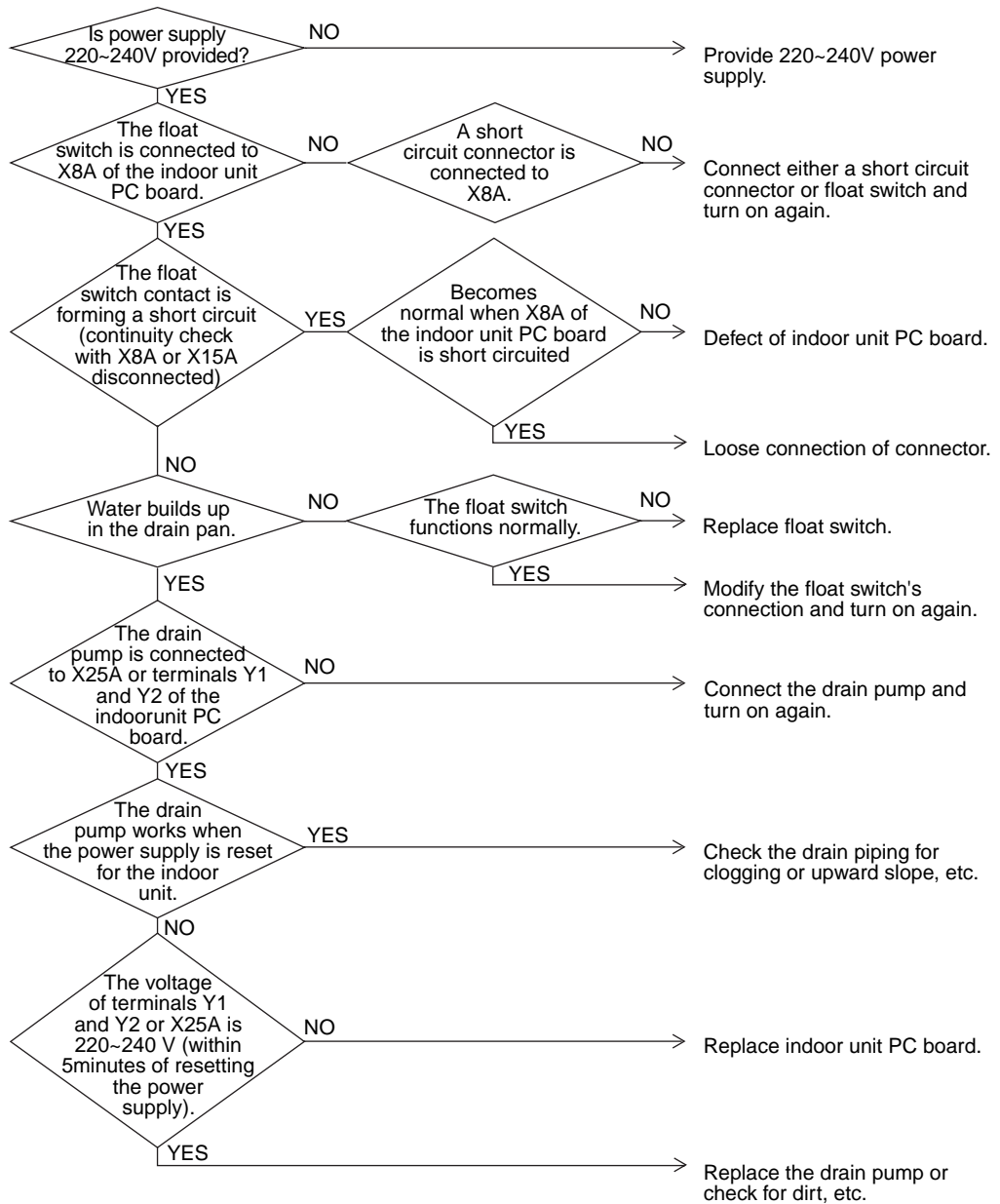

(V2778)

## 2.4 “R6” Indoor Unit: Fan Motor (M1F) Lock, Overload

Remote  
Controller  
Display

R6

Applicable  
Models

All indoor units

Method of  
Malfunction  
Detection

Detection by failure of signal for detecting number of turns to come from the fan motor

Malfunction  
Decision  
Conditions

When number of turns can't be detected even when output voltage to the fan is maximum

Supposed  
Causes

- Fan motor lock
- Disconnected or faulty wiring between fan motor and PC board

Troubleshooting



**Caution**

Be sure to turn off power switch before connect or disconnect connector, or parts damage may be occurred.

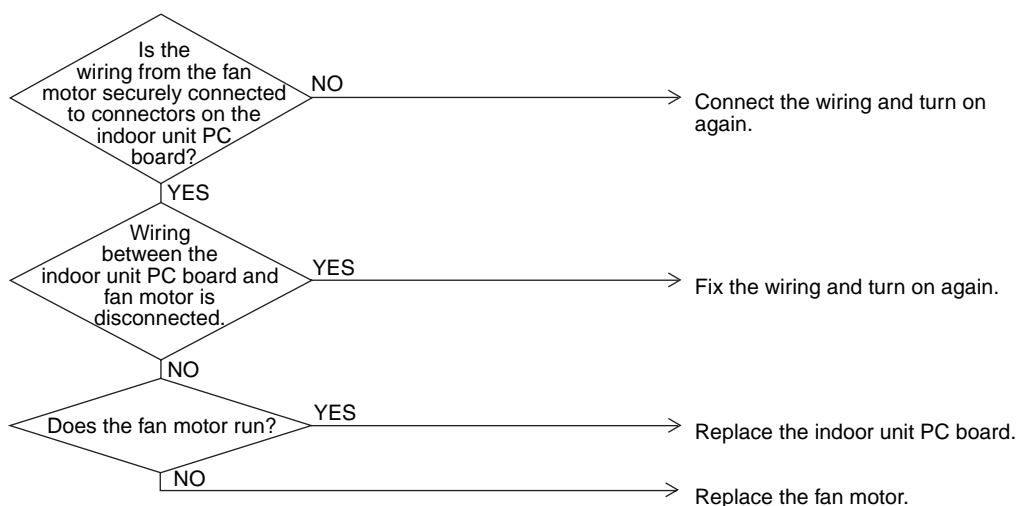

(V2779)

## 2.5 “A7” Indoor Unit: Malfunction of Swing Flap Motor (MA)

---

Remote  
Controller  
Display

*A7*

---

Applicable  
Models

FXCQ, FXHQ, FXKQ

---

Method of  
Malfunction  
Detection

Utilizes ON/OFF of the limit switch when the motor turns.

---

Malfunction  
Decision  
Conditions

When ON/OFF of the microswitch for positioning cannot be reversed even though the swing flap motor is energized for a specified amount of time (about 30 seconds).

---

Supposed  
Causes

- Defect of swing motor
- Defect of connection cable (power supply and limit switch)
- Defect of air flow direction adjusting flap-cam
- Defect of indoor unit PC board

## Troubleshooting

**Caution**

Be sure to turn off power switch before connect or disconnect connector, or parts damage may be occurred.

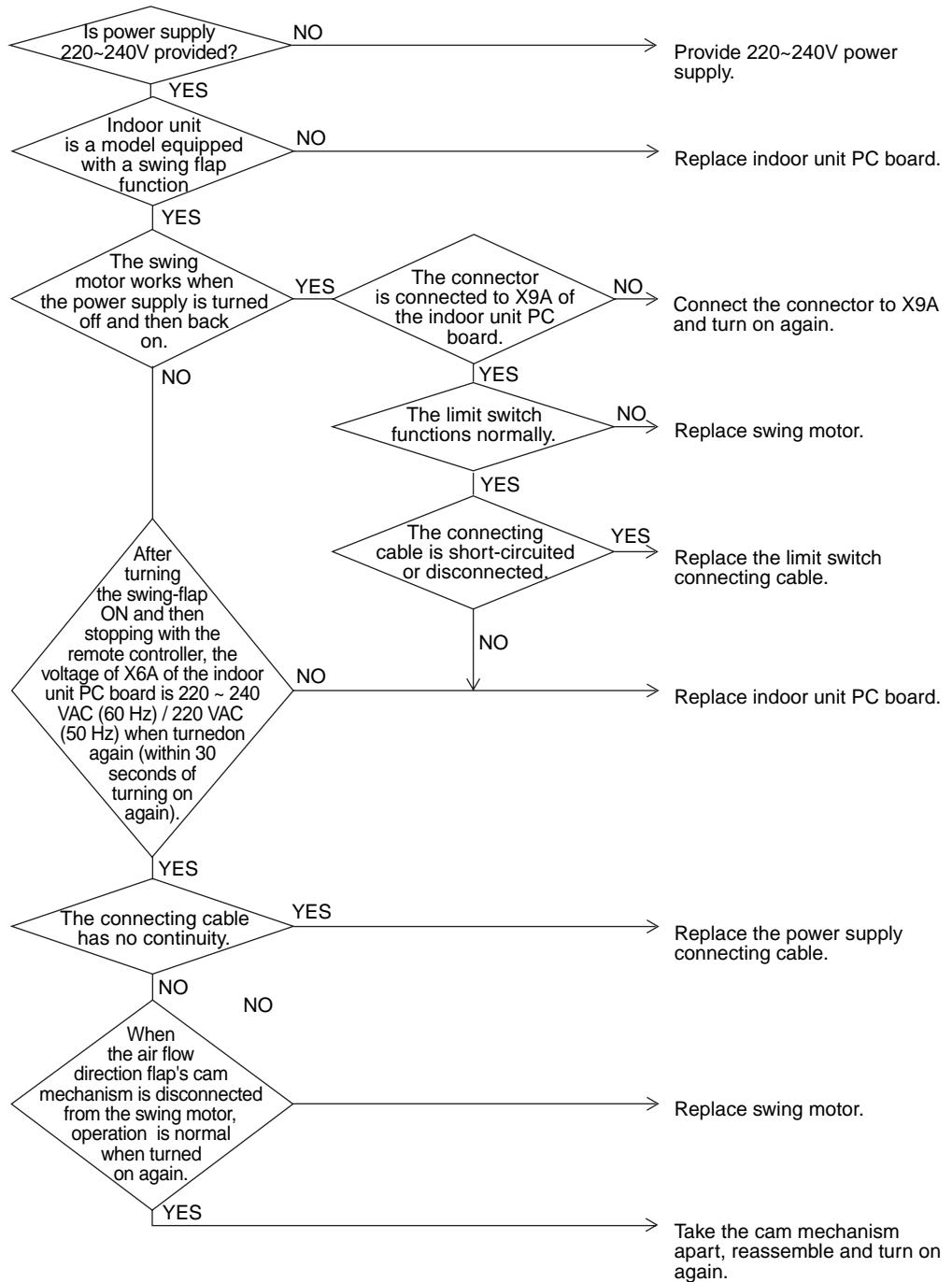

(V2780)

## 2.6 “R9” Indoor Unit: Malfunction of Moving Part of Electronic Expansion Valve (20E)

Remote Controller Display

R9

Applicable Models

All indoor unit models

Method of Malfunction Detection

Detection by failure of signal for detecting number of turns to come from the fan motor

Malfunction Decision Conditions

When number of turns can't be detected even when output voltage to the fan is maximum

Supposed Causes

- Malfunction of moving part of electronic expansion valve
- Defect of indoor unit PC board
- Defect of connecting cable

Troubleshooting



**Caution**

Be sure to turn off power switch before connect or disconnect connector, or parts damage may be occurred.

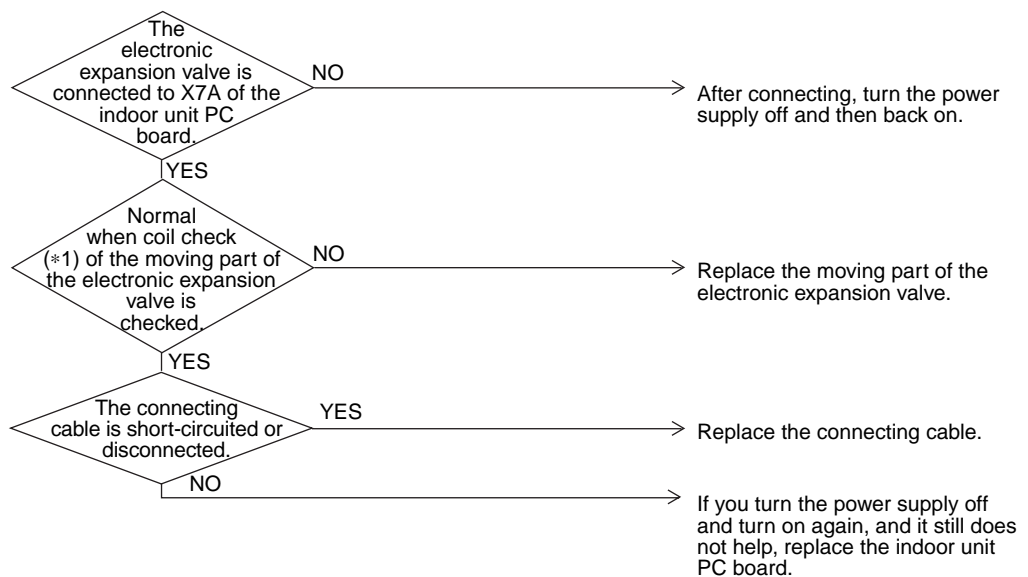

(V2781)

\*1: Coil check method for the moving part of the electronic expansion valve  
Discount the electronic expansion valve from the PC board and check the continuity between the connector pins.

(Normal)

Pin No.	1. White	2. Yellow	3. Orange	4. Blue	5. Red	6. Brown
1. White		x	○ Approx. 300Ω	x	○ Approx. 150Ω	x
2. Yellow			x	○ Approx. 300Ω	x	○ Approx. 150Ω
3. Orange				x	○ Approx. 150Ω	x
4. Blue					x	○ Approx. 150Ω
5. Red						x
6. Brown						

○: Continuity

x: No continuity



## 2.7 “AF” Indoor Unit: Drain Level above Limit

<b>Remote Controller Display</b>	AF
<b>Applicable Models</b>	FXCQ, FXFQ, FXZQ, FXSQ, FXKQ, FXMQ, FXDQ, FXMQ-MF, FXUQ
<b>Method of Malfunction Detection</b>	Water leakage is detected based on float switch ON/OFF operation while the compressor is in non-operation.
<b>Malfunction Decision Conditions</b>	When the float switch changes from ON to OFF while the compressor is in non-operation.
<b>Supposed Causes</b>	<ul style="list-style-type: none"> <li>■ Humidifier unit (optional accessory) leaking</li> <li>■ Defect of drain pipe (upward slope, etc.)</li> <li>■ Defect of indoor unit PC board</li> </ul>

### Troubleshooting



**Caution**

Be sure to turn off power switch before connect or disconnect connector, or parts damage may be occurred.

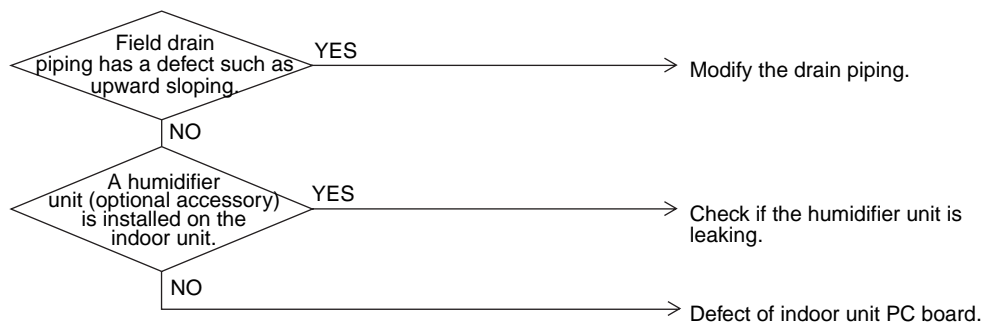

(V2782)

## 2.8 “AU” Indoor Unit: Malfunction of Capacity Determination Device

Remote controller display	AU
Applicable Models	All indoor unit models
Method of Malfunction Detection	Capacity is determined according to resistance of the capacity setting adaptor and the memory inside the IC memory on the indoor unit PC board, and whether the value is normal or abnormal is determined.
Malfunction Decision Conditions	Operation and: 1. When the capacity code is not contained in the PC board's memory, and the capacity setting adaptor is not connected. 2. When a capacity that doesn't exist for that unit is set.
Supposed Causes	<ul style="list-style-type: none"> <li>■ You have forgotten to install the capacity setting adaptor.</li> <li>■ Defect of indoor unit PC board</li> </ul>
Troubleshooting	

**Caution**

Be sure to turn off power switch before connect or disconnect connector, or parts damage may be occurred.

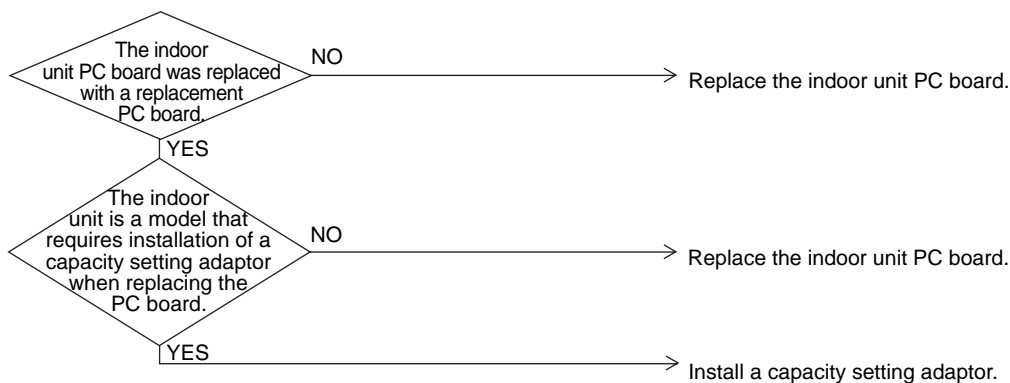

(V2783)

## 2.9 “E4” Indoor Unit: Malfunction of Thermistor (R2T) for Heat Exchanger

<b>Remote Controller Display</b>	E4
<b>Applicable Models</b>	All indoor unit models
<b>Method of Malfunction Detection</b>	Malfunction detection is carried out by temperature detected by heat exchanger thermistor.
<b>Malfunction Decision Conditions</b>	When the heat exchanger thermistor becomes disconnected or shorted while the unit is running.
<b>Supposed Causes</b>	<ul style="list-style-type: none"> <li>■ Defect of thermistor (R2T) for liquid pipe</li> <li>■ Defect of indoor unit PC board</li> </ul>

### Troubleshooting



**Caution**

Be sure to turn off power switch before connect or disconnect connector, or parts damage may be occurred.

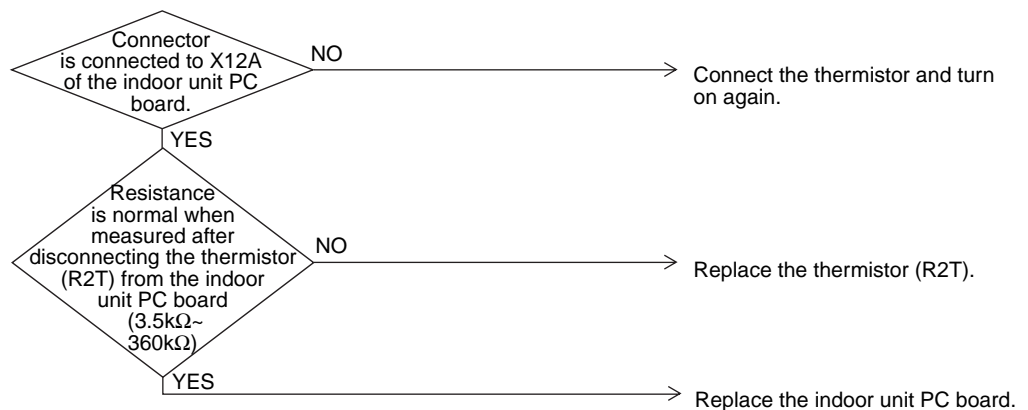

(V2784)



\*2: Refer to thermistor resistance / temperature characteristics table on P311.

## 2.10 “E5” Indoor Unit: Malfunction of Thermistor (R3T) for Gas Pipes

Remote  
Controller  
Display

E5

Applicable  
Models

All indoor unit models

Method of  
Malfunction  
Detection

Malfunction detection is carried out by temperature detected by gas pipe thermistor.

Malfunction  
Decision  
Conditions

When the gas pipe thermistor becomes disconnected or shorted while the unit is running.

Supposed  
Causes

- Defect of indoor unit thermistor (R3T) for gas pipe
- Defect of indoor unit PC board

Troubleshooting



**Caution**

Be sure to turn off power switch before connect or disconnect connector, or parts damage may be occurred.

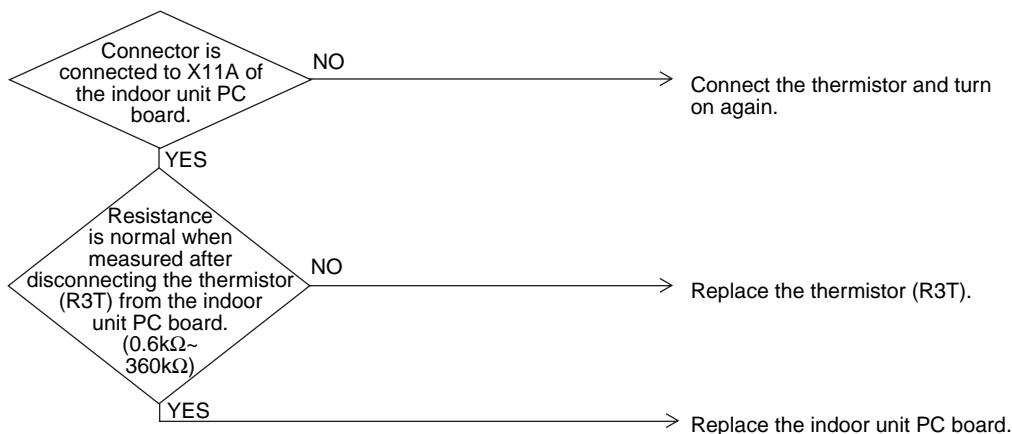

(V2785)



\*2: Refer to thermistor resistance / temperature characteristics table on P311.

## 2.11 “E9” Indoor Unit: Malfunction of Thermistor (R1T) for Suction Air

<b>Remote Controller Display</b>	E9
<b>Applicable Models</b>	All indoor unit models
<b>Method of Malfunction Detection</b>	Malfunction detection is carried out by temperature detected by suction air temperature thermistor.
<b>Malfunction Decision Conditions</b>	When the suction air temperature thermistor becomes disconnected or shorted while the unit is running.
<b>Supposed Causes</b>	<ul style="list-style-type: none"> <li>■ Defect of indoor unit thermistor (R1T) for air inlet</li> <li>■ Defect of indoor unit PC board</li> </ul>

### Troubleshooting



**Caution**

Be sure to turn off power switch before connect or disconnect connector, or parts damage may be occurred.

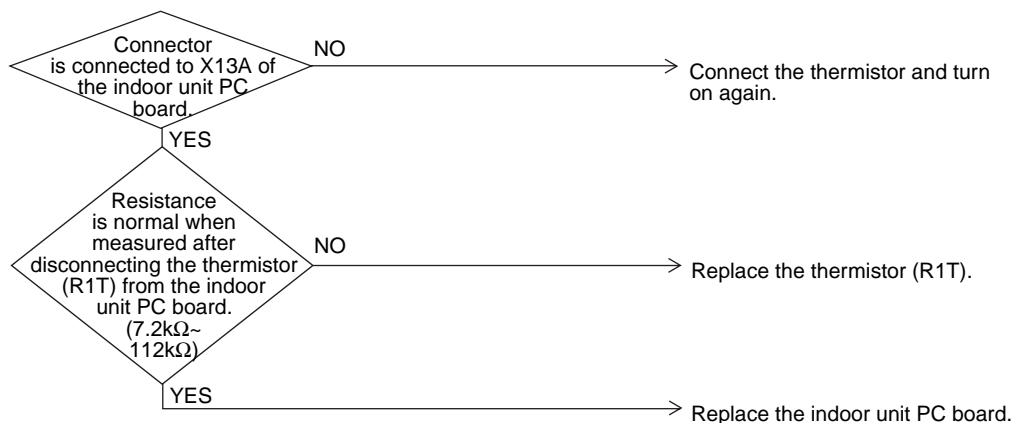

(V2786)



\*2: Refer to thermistor resistance / temperature characteristics table on P311.

## 2.12 “CJ” Indoor Unit: Malfunction of Thermostat Sensor in Remote Controller

Remote Controller Display	CJ
Applicable Models	All indoor unit models
Method of Malfunction Detection	Malfunction detection is carried out by temperature detected by remote controller air temperature thermistor. (Note1)
Malfunction Decision Conditions	When the remote controller air temperature thermistor becomes disconnected or shorted while the unit is running.
Supposed Causes	<ul style="list-style-type: none"> <li>■ Defect of remote controller thermistor</li> <li>■ Defect of remote controller PC board</li> </ul>

### Troubleshooting

**Caution**

Be sure to turn off power switch before connect or disconnect connector, or parts damage may be occurred.

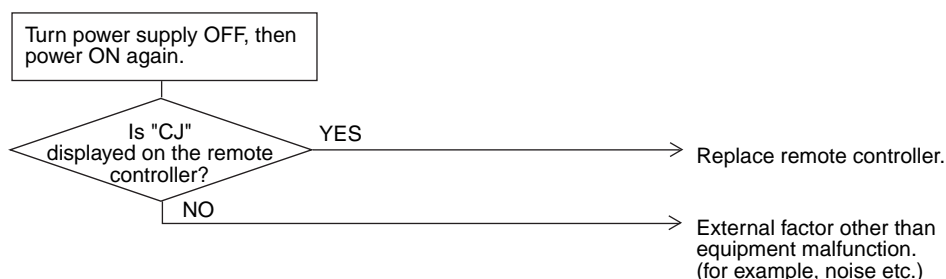

(V2787)

**Note:**

In case of remote controller thermistor malfunction, unit is still operable by suction air thermistor on indoor unit.



\*2: Refer to thermistor resistance / temperature characteristics table on P311.

## 2.13 “E1” Outdoor Unit: PC Board Defect

Remote Controller Display

E1

Applicable Models

RXYQ5~48M

Method of Malfunction Detection

Check data from E<sup>2</sup>PROM

Malfunction Decision Conditions

When data could not be correctly received from the E<sup>2</sup>PROM  
 E<sup>2</sup>PROM : Type of nonvolatile memory. Maintains memory contents even when the power supply is turned off.

Supposed Causes

- Defect of outdoor unit PC board (A1P)

Troubleshooting



**Caution**

Be sure to turn off power switch before connect or disconnect connector, or parts damage may be occurred.

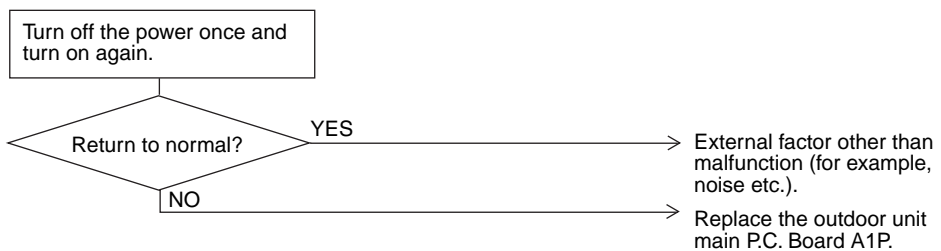

(V3064)

## 2.14 “E3” Outdoor Unit: Actuation of High Pressure Switch

Remote  
Controller  
Display

E3

Applicable  
Models

RXYQ5~48M

Method of  
Malfunction  
Detection

Abnormality is detected when the contact of the high pressure protection switch opens.

Malfunction  
Decision  
Conditions

Error is generated when the HPS activation count reaches the number specific to the operation mode.

Supposed  
Causes

- Actuation of outdoor unit high pressure switch
- Defect of High pressure switch
- Defect of outdoor unit PC board
- Instantaneous power failure
- Faulty high pressure sensor

Troubleshooting



**Caution**

Be sure to turn off power switch before connect or disconnect connector, or parts damage may be occurred.

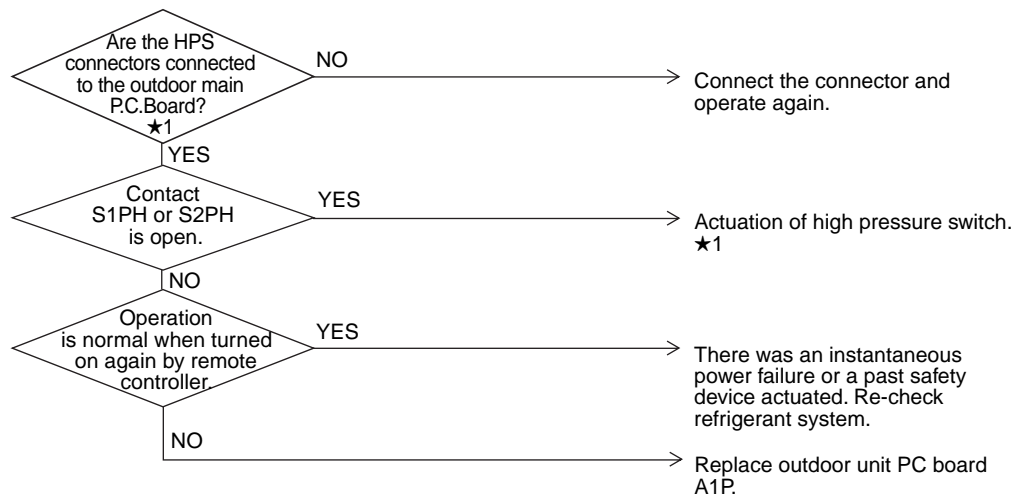

(V3065)

H1: Actuation of high pressure switch (HPS)

- The outdoor unit PC board's connector is disconnected.
- Is the outdoor unit heat exchanger dirty?
- Defect of outdoor fan
- Is the refrigerant over-charged?
- Faulty high pressure sensor



## 2.15 “E4” Outdoor Unit: Actuation of Low Pressure Sensor

Remote Controller Display

E4

Applicable Models

RXYQ5~48M

Method of Malfunction Detection

Malfunction Decision Conditions

Error is generated when the low pressure is dropped under specific pressure.

Supposed Causes

- Abnormal drop of low pressure (Lower than 0.07MPa)
- Defect of low pressure sensor
- Defect of outdoor unit PC board
- Stop valve is not opened.

Troubleshooting



**Caution**

Be sure to turn off power switch before connect or disconnect connector, or parts damage may be occurred.

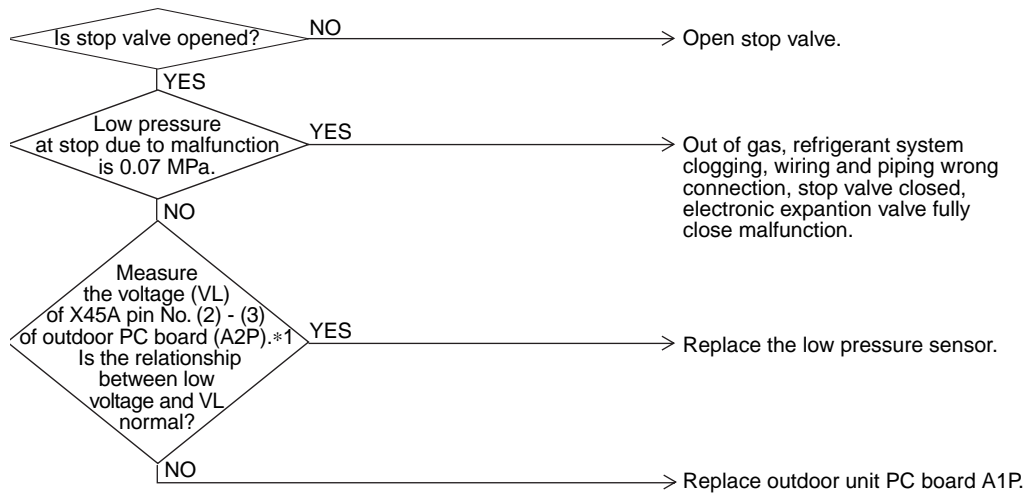

(V2791)

\*1: Voltage measurement point

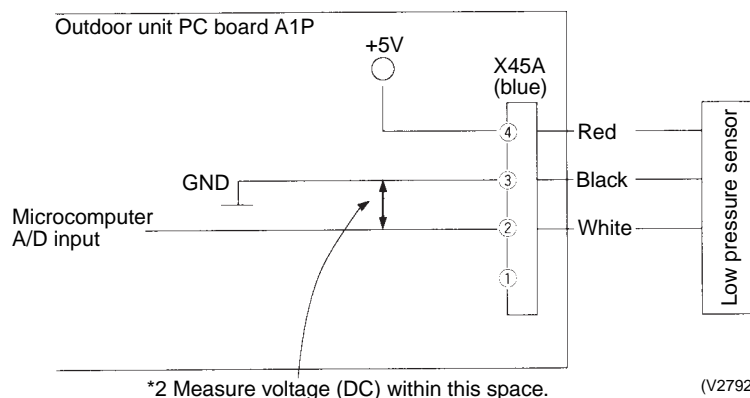

(V2792)



\*2: Refer to pressure sensor, pressure / voltage characteristics table on P313.

## 2.16 “E5” Compressor Motor Lock

Remote  
Controller  
Display

E5

Applicable  
Models

RXYQ5~48M

Method of  
Malfunction  
Detection

Inverter PC board takes the position signal from UVWN line connected between the inverter and compressor, and detects the position signal pattern.

Malfunction  
Decision  
Conditions

The position signal with 3 times cycle as imposed frequency is detected when compressor motor operates normally, but 2 times cycle when compressor motor locks. When the position signal in 2 times cycle is detected.

Supposed  
Causes

- Compressor lock
- High differential pressure (0.5MPa or more)
- Incorrect UVWN wiring
- Faulty inverter PC board
- Stop valve is left in closed.

Troubleshooting



**Caution**

Be sure to turn off power switch before connect or disconnect connector, or parts damage may be occurred.

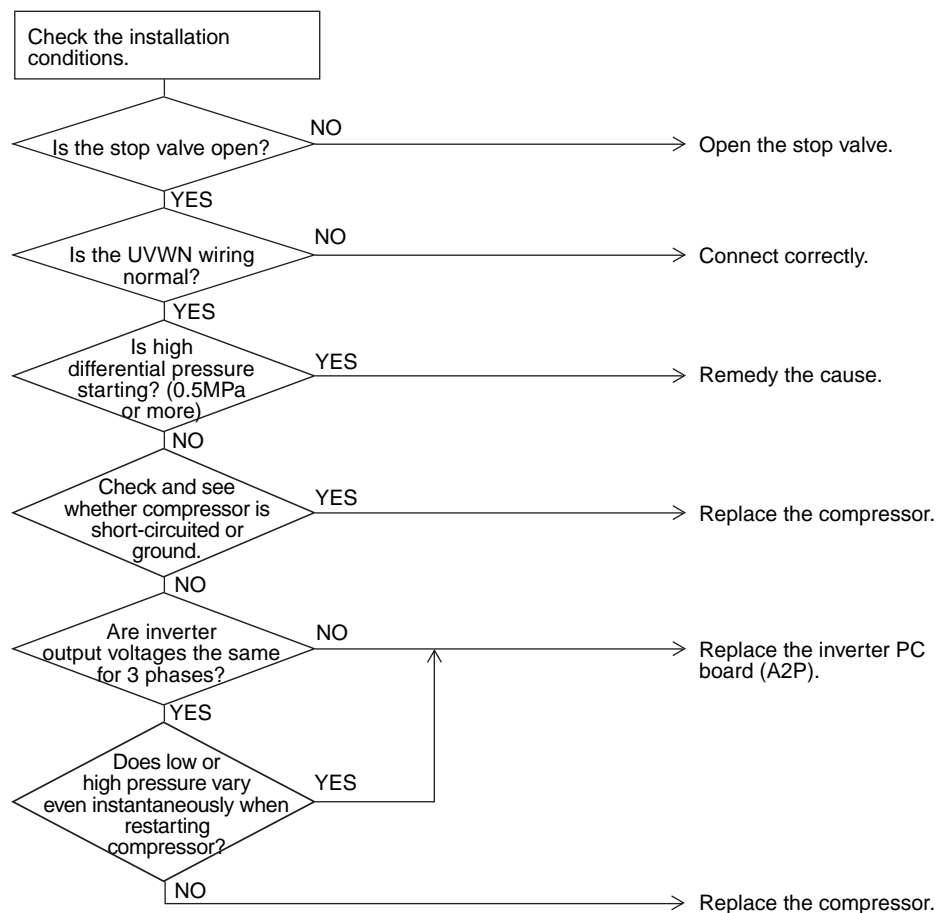

(V2793)

## 2.17 “E6” Compressor Motor Overcurrent/Lock

<b>Remote Controller Display</b>	E6
<b>Applicable Models</b>	Outdoor unit
<b>Method of Malfunction Detection</b>	Detects the overcurrent with current sensor (CT).
<b>Malfunction Decision Conditions</b>	Malfunction is decided when the detected current value exceeds the below mentioned value for 2 seconds. <ul style="list-style-type: none"> <li>■ 400 V unit : 15.0 A</li> </ul>
<b>Supposed Causes</b>	<ul style="list-style-type: none"> <li>■ Closed stop valve</li> <li>■ Obstacles at the discharge port</li> <li>■ Improper power voltage</li> <li>■ Faulty magnetic switch</li> <li>■ Faulty compressor</li> </ul>

### Troubleshooting



**Caution**

Be sure to turn off power switch before connect or disconnect connector, or parts damage may be occurred.

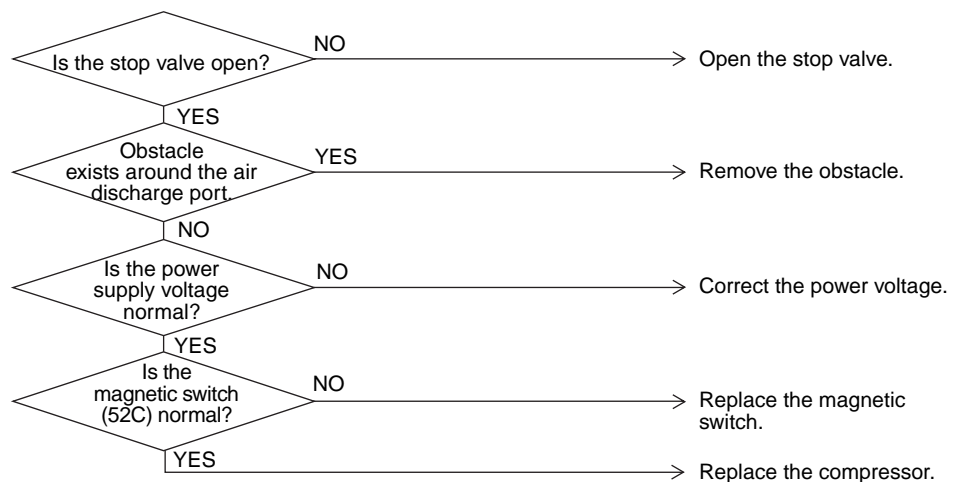

(V3051)

## 2.18 “E7” Malfunction of Outdoor Unit Fan Motor

Remote Controller Display

E7

Applicable Models

RXYQ5~48M

Method of Malfunction Detection

Malfunction of fan motor system is detected according to the fan speed detected by hall IC when the fan motor runs.

Malfunction Decision Conditions

- When the fan runs with speed less than a specified one for 15 seconds or more when the fan motor running conditions are met
- When connector detecting fan speed is disconnected
- When malfunction is generated 4 times, the system shuts down.

Supposed Causes

- Malfunction of fan motor
- The harness connector between fan motor and PC board is left in disconnected, or faulty connector
- Fan does not run due to foreign matters tangled
- Clearing condition: Operate for 5 minutes (normal)

### Troubleshooting



**Caution**

Be sure to turn off power switch before connect or disconnect connector, or parts damage may be occurred.

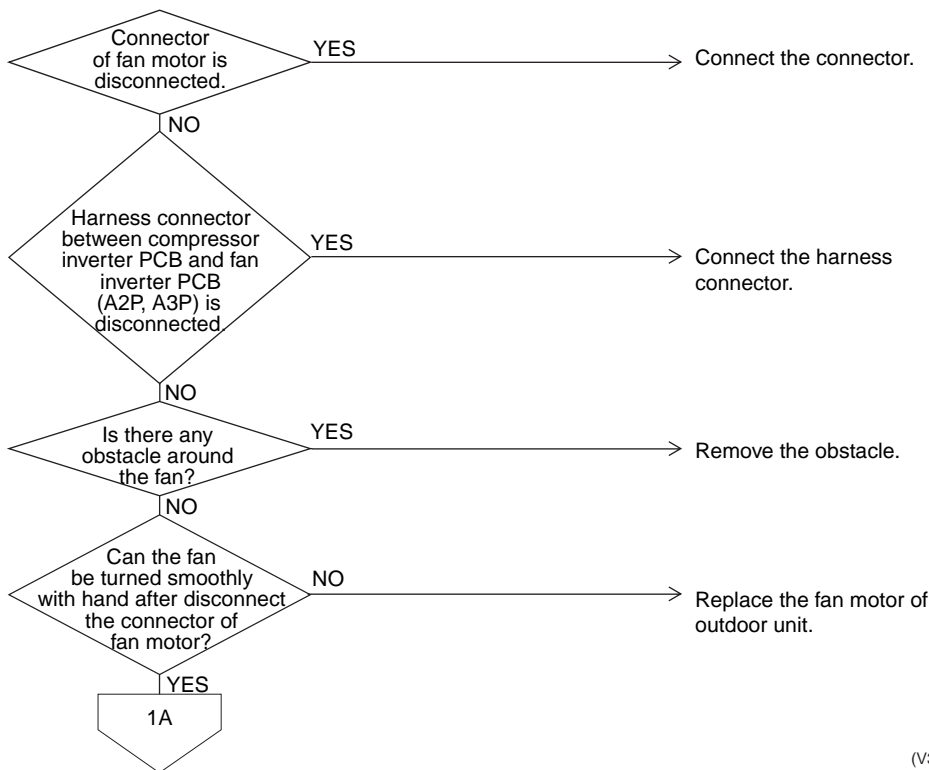

(V3076)

Troubleshooting

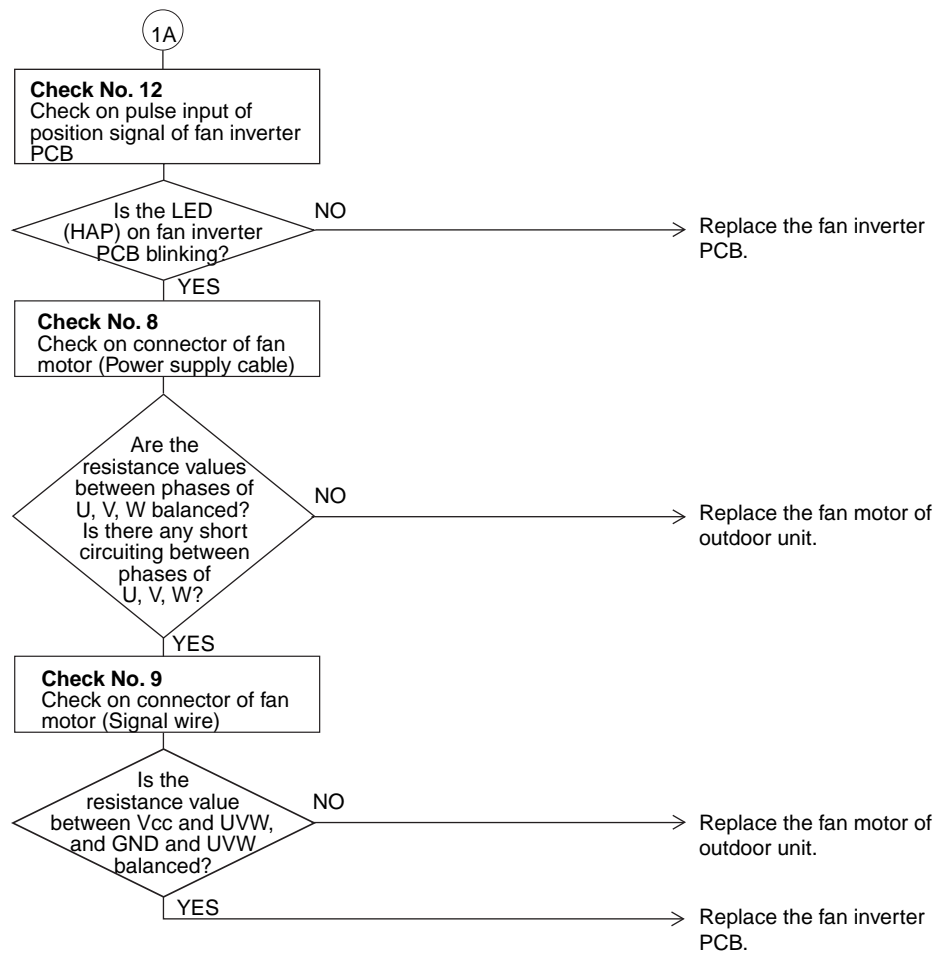

(V3077)

**i** **Note:** Refer check 8, 9 and 12 to P.255~256.

## 2.19 “E9” Outdoor Unit: Malfunction of Moving Part of Electronic Expansion Valve (Y1E, Y2E)

Remote  
Controller  
Display

E9

Applicable  
Models

RXYQ5~48M

Method of  
Malfunction  
Detection

Check disconnection of connector  
Check continuity of expansion valve coil

Malfunction  
Decision  
Conditions

Error is generated under no common power supply when the power is on.

Supposed  
Causes

- Defect of moving part of electronic expansion valve
- Defect of outdoor unit PC board (A1P)
- Defect of connecting cable

### Troubleshooting

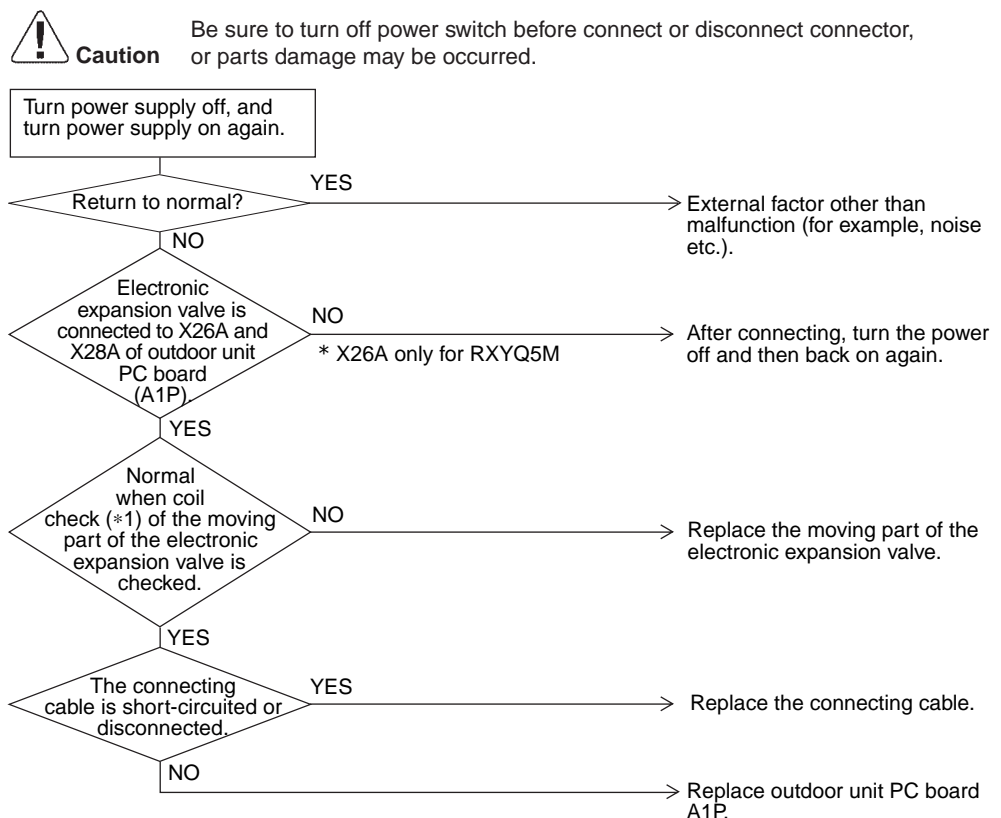

(V3067)

\*1 Coil check method for the moving part of the electronic expansion valve  
 Disconnect the electronic expansion valve from the PC board and check the continuity between the connector pins.

(Normal)

Pin No.	1. White	2. Yellow	3. Orange	4. Blue	5. Red	6. Brown
1. White		x	⊙	x	○	x
2. Yellow			x	⊙	x	○
3. Orange				x	○	x
4. Blue					x	○
5. Red						x
6. Brown						

⊙ : Continuity Approx. 300Ω

○ : Continuity Approx. 150Ω

x : No continuity

## 2.20 “F3” Outdoor Unit: Abnormal Discharge Pipe Temperature

Remote  
Controller  
Display

F3

Applicable  
Models

RXYQ5~48M

Method of  
Malfunction  
Detection

Abnormality is detected according to the temperature detected by the discharge pipe temperature sensor.

Malfunction  
Decision  
Conditions

- When the discharge pipe temperature rises to an abnormally high level
- When the discharge pipe temperature rises suddenly

Supposed  
Causes

- Faulty discharge pipe temperature sensor
- Faulty connection of discharge pipe temperature sensor
- Faulty outdoor unit PCB

### Troubleshooting



**Caution**

Be sure to turn off power switch before connect or disconnect connector, or parts damage may be occurred.

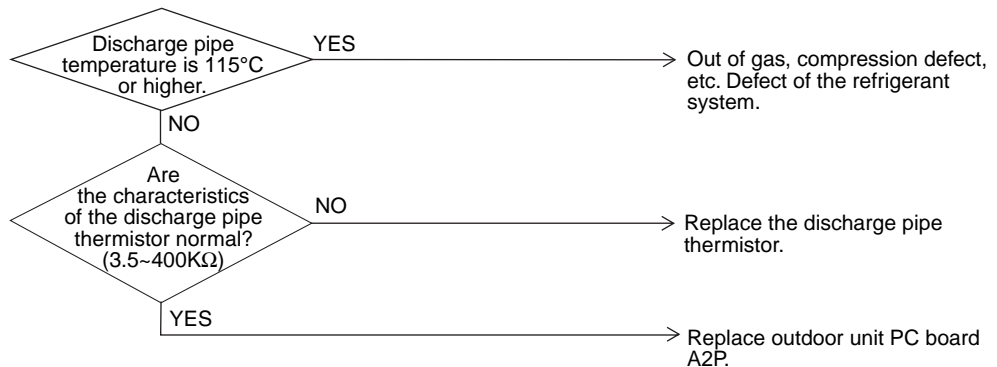

(V3068)



\*2: Refer to thermistor resistance / temperature characteristics table on P311.



## 2.21 “F6” Refrigerant Overcharged

<b>Remote Controller Display</b>	F6
<b>Applicable Models</b>	RXYQ5~48M
<b>Method of Malfunction Detection</b>	Refrigerant overcharge is detected from the receiver gas pipe temperature during test operation.
<b>Malfunction Decision Conditions</b>	When the receiver gas pipe temperature is lower than evaporating temperature during test operation.
<b>Supposed Causes</b>	<ul style="list-style-type: none"> <li>■ Refrigerant overcharge</li> <li>■ Disconnection of the receiver gas pipe thermistor</li> </ul>

### Troubleshooting



**Caution**

Be sure to turn off power switch before connect or disconnect connector, or parts damage may be occurred.

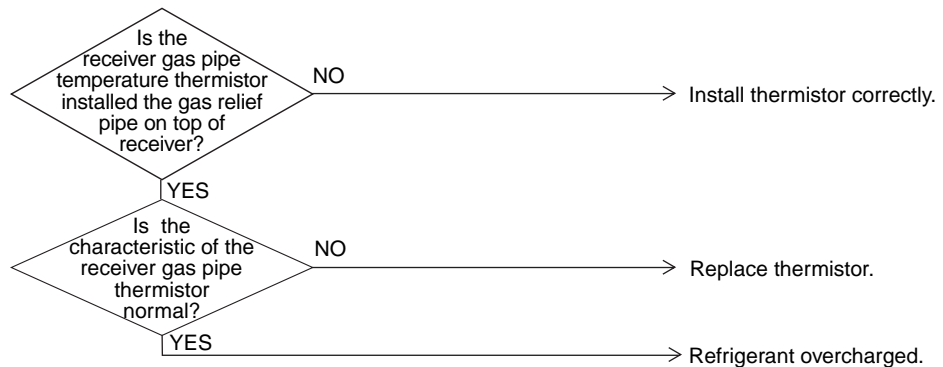

(V2797)

## 2.22 “H7” Abnormal Outdoor Fan Motor Signal

Remote  
Controller  
Display

H7

Applicable  
Models

RXYQ5~48M

Method of  
Malfunction  
Detection

Detection of abnormal signal from fan motor.

Malfunction  
Decision  
Conditions

In case of detection of abnormal signal at starting fan motor.

Supposed  
Causes

- Abnormal fan motor signal (circuit malfunction)
- Broken, short or disconnection connector of fan motor connection cable
- Fan Inverter PC board malfunction

Troubleshooting

 **Caution** Be sure to turn off power switch before connect or disconnect connector, or parts damage may be occurred.

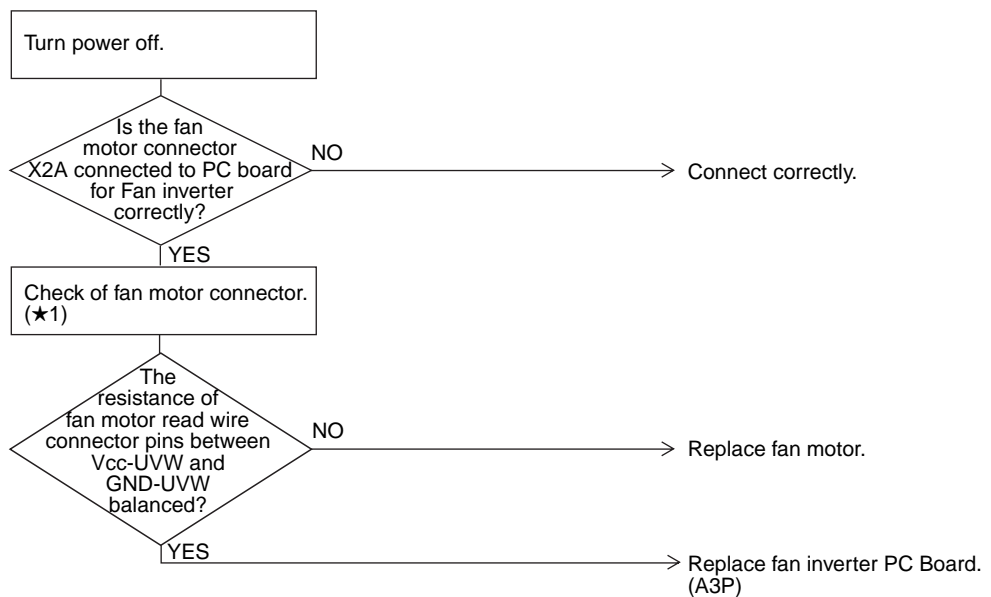

(V3069)

H1: Disconnect connector (X2A) and measure the following resistance.

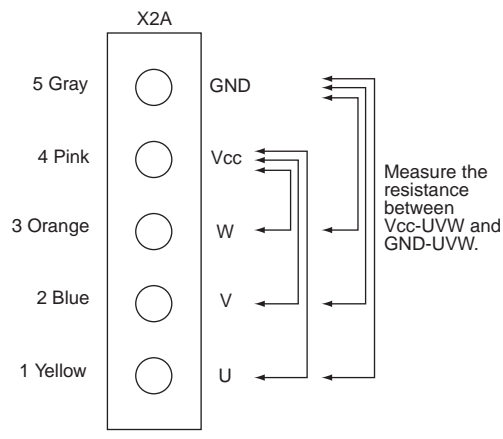

(V2799)

## 2.23 “H9” Outdoor Unit: Malfunction of Thermistor for Outdoor Air (R1T)

Remote Controller Display	H9
Applicable Models	RXYQ5~48M
Method of Malfunction Detection	The abnormal detection is based on current detected by current sensor.
Malfunction Decision Conditions	When the outside air temperature sensor has short circuit or open circuit.
Supposed Causes	<ul style="list-style-type: none"> <li>■ Defect of thermistor (R1T) for outdoor air</li> <li>■ Defect of outdoor unit PC board (A1P)</li> </ul>

### Troubleshooting

 **Caution** Be sure to turn off power switch before connect or disconnect connector, or parts damage may be occurred.

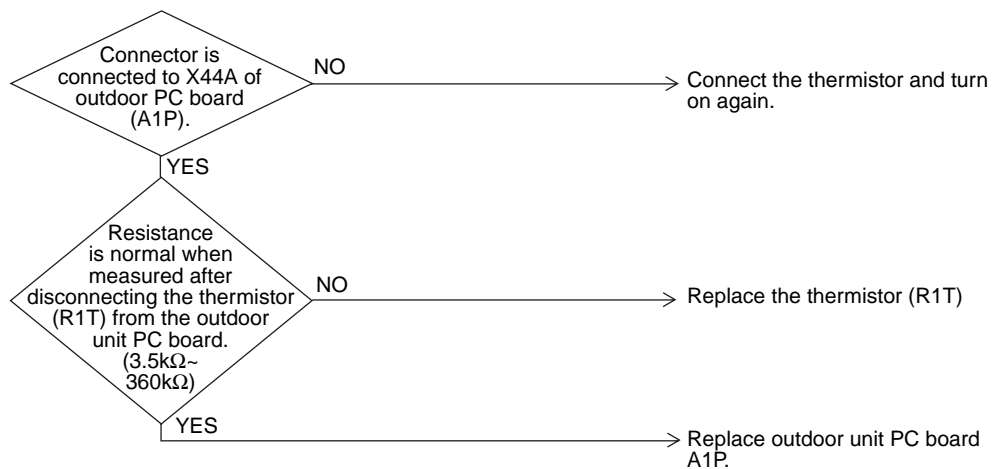

(V3070)

The alarm indicator is displayed when the fan only is being used also.



\*2: Refer to thermistor resistance / temperature characteristics table on P311.

## 2.24 “J2” Current Sensor Malfunction

Remote  
Controller  
Display

J2

Applicable  
Models

RXYQ5~48M

Method of  
Malfunction  
Detection

Malfunction is detected according to the current value detected by current sensor.

Malfunction  
Decision  
Conditions

When the current value detected by current sensor becomes 5A or lower, or 40A or more during standard compressor operation.

Supposed  
Causes

- Faulty current sensor
- Faulty outdoor unit PC board

Troubleshooting



**Caution**

Be sure to turn off power switch before connect or disconnect connector, or parts damage may be occurred.

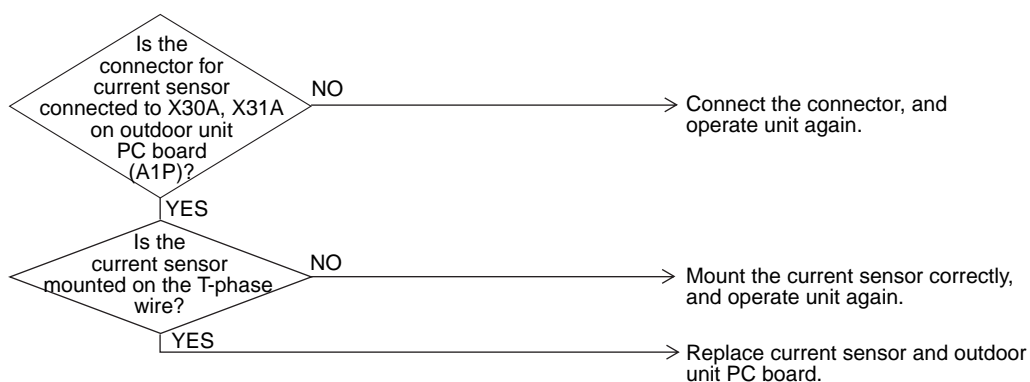

(V3071)

## 2.25 “J3” Outdoor Unit: Malfunction of Discharge Pipe Thermistor (R3, R31~33T)

Remote Controller Display	J3
Applicable Models	RXYQ5~48M
Method of Malfunction Detection	Malfunction is detected from the temperature detected by discharge pipe temperature thermistor.
Malfunction Decision Conditions	When a short circuit or an open circuit in the discharge pipe temperature thermistor is detected.
Supposed Causes	<ul style="list-style-type: none"> <li>■ Defect of thermistor (R31T, R32T or R33T) for outdoor unit discharge pipe</li> <li>■ Defect of outdoor unit PC board (A1P)</li> </ul>

### Troubleshooting

 **Caution** Be sure to turn off power switch before connect or disconnect connector, or parts damage may be occurred.

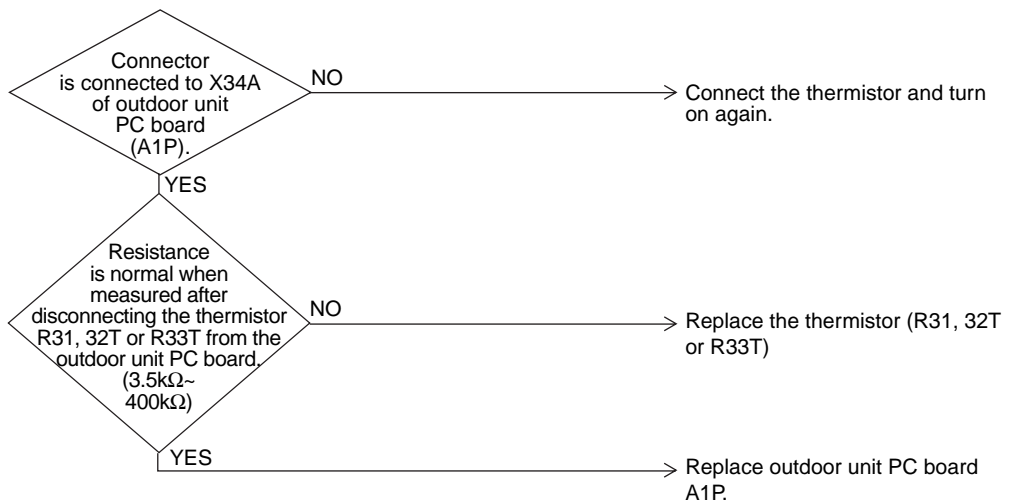

(V3072)

The alarm indicator is displayed when the fan is being used also.

 **Note:** 5 HP class ... R3T  
 8~12 HP class ... R31T, R32T  
 14, 16Hp class ... R31T, R32T and R33T

## 2.26 “J5” Outdoor Unit: Malfunction of Thermistor (R2T) for Suction Pipe

Remote  
Controller  
Display

J5

Applicable  
Models

RXYQ5~48M

Method of  
Malfunction  
Detection

Malfunction is detected from the temperature detected by the suction pipe temperature thermistor.

Malfunction  
Decision  
Conditions

When a short circuit or an open circuit in the suction pipe temperature thermistor is detected.

Supposed  
Causes

- Defect of thermistor (R2T) for outdoor unit suction pipe
- Defect of outdoor unit PC board (A1P)

Troubleshooting



**Caution**

Be sure to turn off power switch before connect or disconnect connector, or parts damage may be occurred.

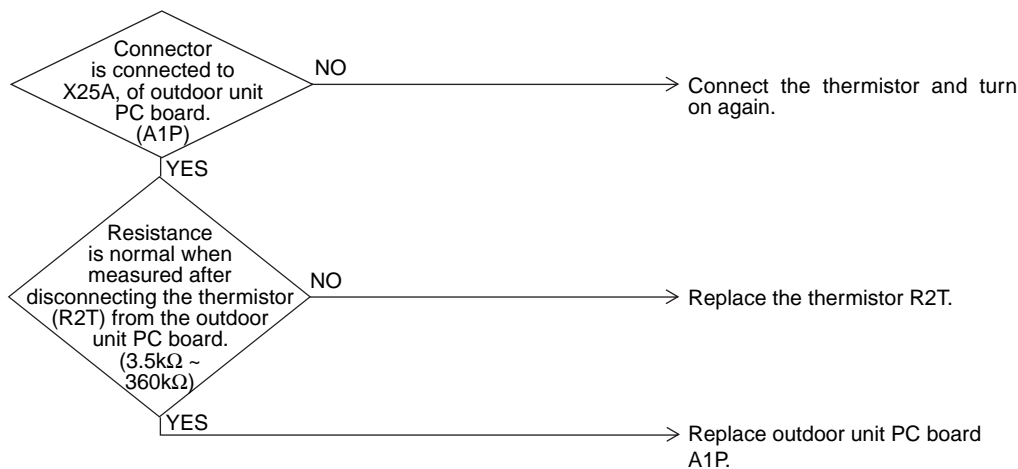

(V3073)



\*2: Refer to thermistor resistance / temperature characteristics table on P311.

## 2.27 “J6” Outdoor Unit: Malfunction of Thermistor (R4T) for Outdoor Unit Heat Exchanger

Remote Controller Display	J6
Applicable Models	RXYQ5~48M
Method of Malfunction Detection	Malfunction is detected from the temperature detected by the heat exchanger thermistor.
Malfunction Decision Conditions	When a short circuit or an open circuit in the heat exchange thermistor is detected.
Supposed Causes	<ul style="list-style-type: none"> <li>■ Defect of thermistor (R4T) for outdoor unit coil</li> <li>■ Defect of outdoor unit PC board (A1P)</li> </ul>
Troubleshooting	



**Caution**

Be sure to turn off power switch before connect or disconnect connector, or parts damage may be occurred.

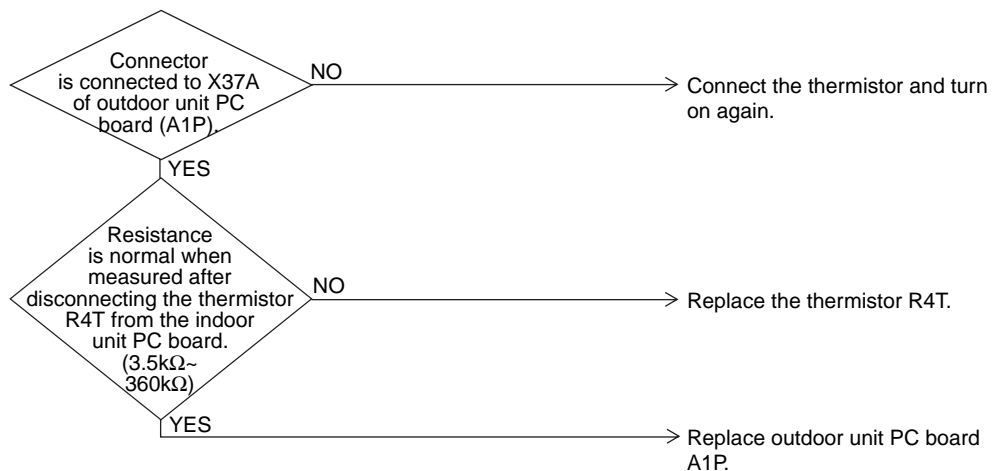

(V3074)



\*2: Refer to thermistor resistance / temperature characteristics table on P311.

## 2.28 “J8” Malfunction of Oil Equalizing Pipe Thermistor (R7T)

Remote Controller Display	J8
Applicable Models	RXYQ5~48M
Method of Malfunction Detection	Malfunction is detected according to the temperature detected by oil equalizing pipe thermistor.
Malfunction Decision Conditions	When the oil equalizing pipe thermistor is short circuited or open.
Supposed Causes	<ul style="list-style-type: none"> <li>■ Faulty oil equalizing pipe thermistor (R7T)</li> <li>■ Faulty outdoor unit PC board</li> </ul>
Troubleshooting	

**Caution**

Be sure to turn off power switch before connect or disconnect connector, or parts damage may be occurred.

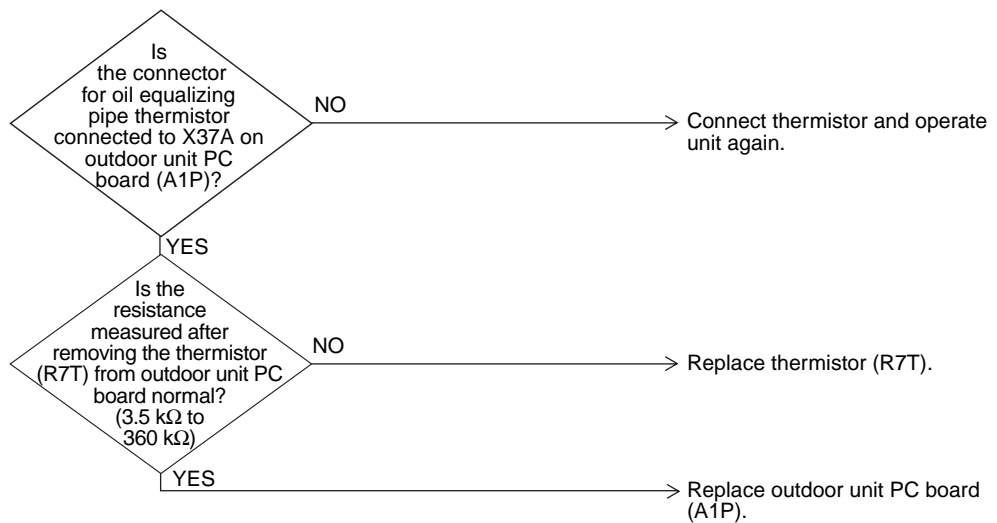

(V3075)



\*2: Refer to thermistor resistance / temperature characteristics table on P311.



## 2.29 “J9” Malfunction of Receiver Gas Pipe Thermistor (R5T)

Remote Controller Display	J9
Applicable Models	RXYQ5~48M
Method of Malfunction Detection	Malfunction is detected according to the temperature detected by receiver gas pipe thermistor.
Malfunction Decision Conditions	When the receiver gas pipe thermistor is short circuited or open.
Supposed Causes	<ul style="list-style-type: none"> <li>■ Faulty receiver gas pipe thermistor (R5T)</li> <li>■ Faulty outdoor unit PC board</li> </ul>
Troubleshooting	

 **Caution** Be sure to turn off power switch before connect or disconnect connector, or parts damage may be occurred.

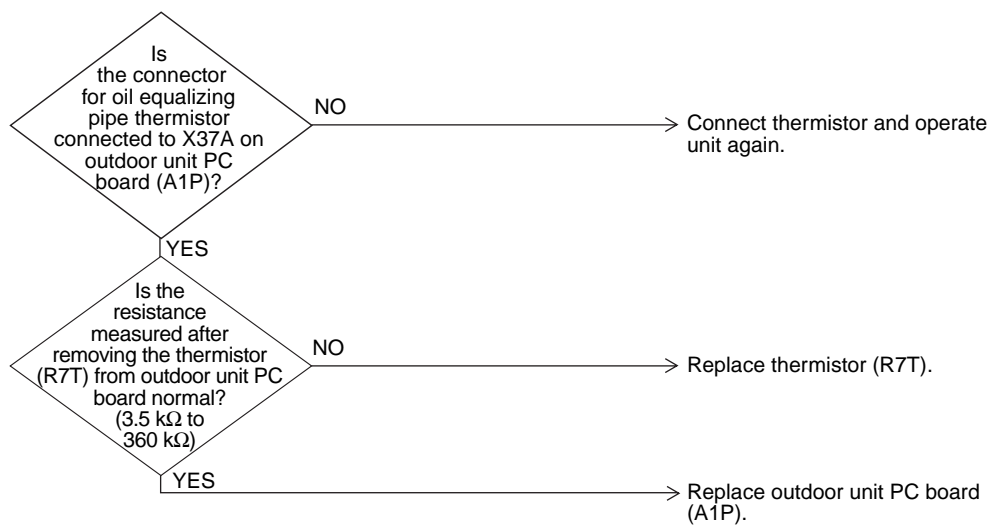

(V3075)



\*2: Refer to thermistor resistance / temperature characteristics table on P311.

## 2.30 “JA” Outdoor Unit: Malfunction of Discharge Pipe Pressure Sensor

Remote Controller Display

JA

Applicable Models

RXYQ5~48M

Method of Malfunction Detection

Malfunction is detected from the pressure detected by the high pressure sensor.

Malfunction Decision Conditions

When the discharge pipe pressure sensor is short circuit or open circuit.

Supposed Causes

- Defect of high pressure sensor system
- Connection of low pressure sensor with wrong connection.
- Defect of outdoor unit PC board.

### Troubleshooting



**Caution**

Be sure to turn off power switch before connect or disconnect connector, or parts damage may be occurred.

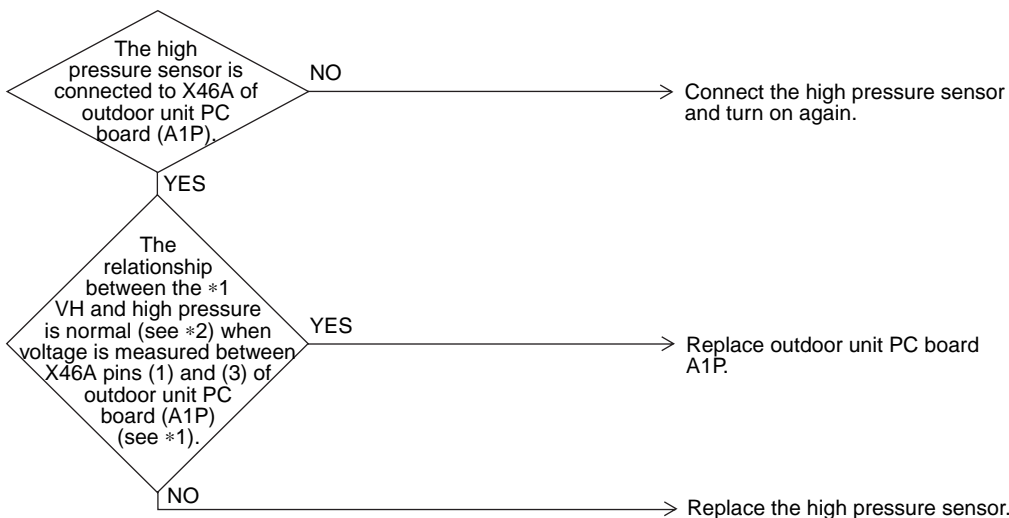

(V2806)

\*1: Voltage measurement point

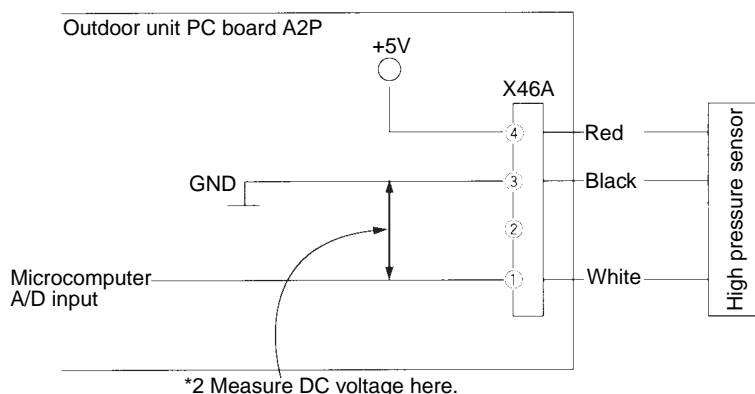

\*2 Measure DC voltage here.

(V2807)



\*2: Refer to pressure sensor, pressure / voltage characteristics table on P313.

## 2.31 “JL” Outdoor Unit: Malfunction of Suction Pipe Pressure Sensor

Remote Controller Display



Applicable Models

RXYQ5~48M

Method of Malfunction Detection

Malfunction is detected from pressure detected by low pressure sensor.

Malfunction Decision Conditions

When the suction pipe pressure sensor is short circuit or open circuit.

Supposed Causes

- Defect of low pressure sensor system
- Connection of high pressure sensor with wrong connection.
- Defect of outdoor unit PC board.

### Troubleshooting



**Caution**

Be sure to turn off power switch before connect or disconnect connector, or parts damage may be occurred.

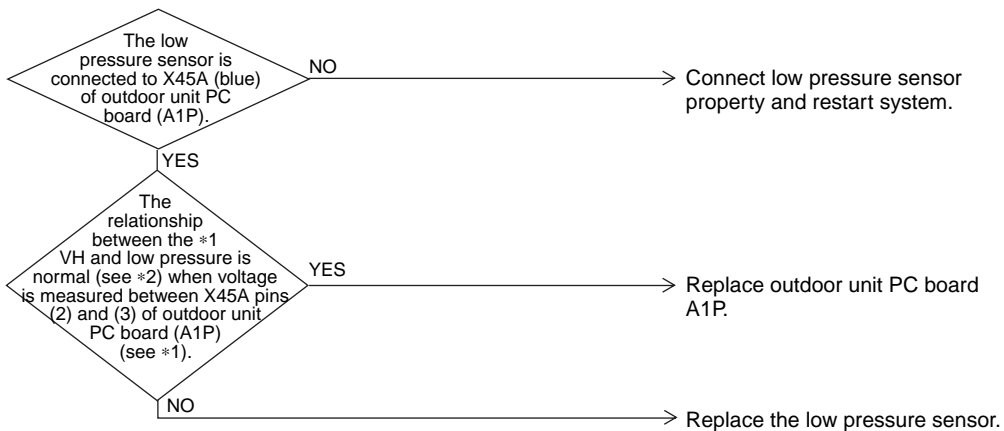

(V2808)

\*1: Voltage measurement point

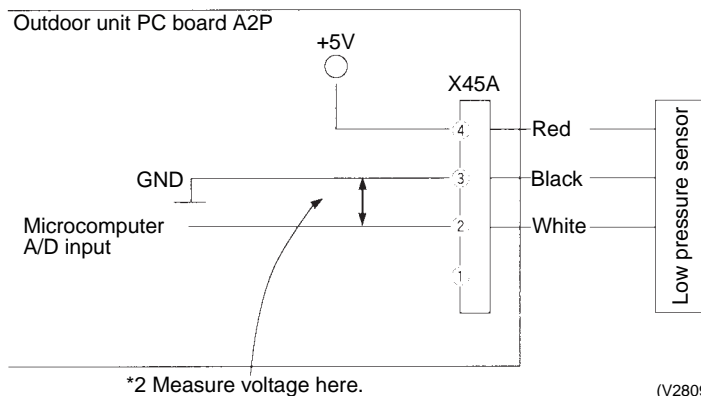

(V2809)



\*2: Refer to pressure sensor, pressure/voltage characteristics table on P313.

## 2.32 “L4” Outdoor Unit: Malfunction of Inverter Radiating Fin Temperature Rise

Remote  
Controller  
Display

L4

Applicable  
Models

RXYQ5~48M

Method of  
Malfunction  
Detection

Fin temperature is detected by the thermistor of the radiation fin.

Malfunction  
Decision  
Conditions

When the temperature of the inverter radiation fin increases above 89°C.

Supposed  
Causes

- Actuation of fin thermal (Actuates above 89°C)
- Defect of inverter PC board
- Defect of fin thermistor

Troubleshooting



**Caution**

Be sure to turn off power switch before connect or disconnect connector, or parts damage may be occurred.

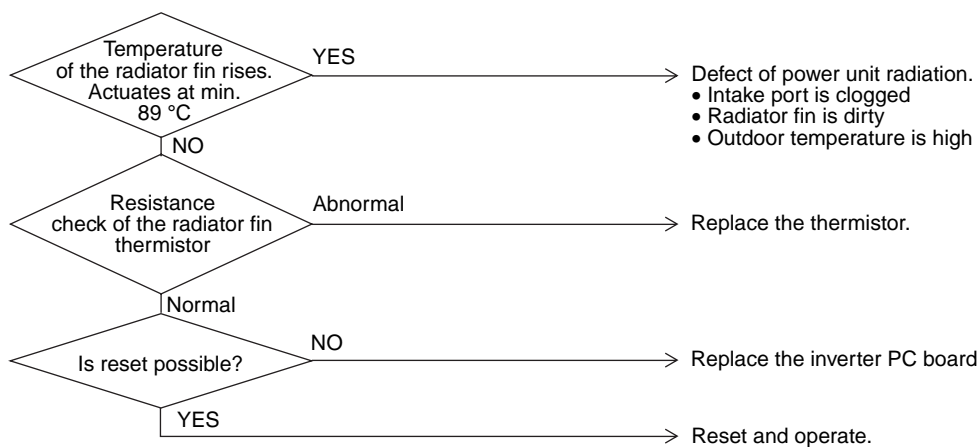

(V2811)



\*2: Refer to thermistor resistance / temperature characteristics table on P311.

## 2.33 “L5” Outdoor Unit: Inverter Compressor Abnormal

<b>Remote Controller Display</b>	L5
<b>Applicable Models</b>	RXYQ5~48M
<b>Method of Malfunction Detection</b>	Malfunction is detected from current flowing in the power transistor.
<b>Malfunction Decision Conditions</b>	When an excessive current flows in the power transistor. (Instantaneous overcurrent also causes activation.)
<b>Supposed Causes</b>	<ul style="list-style-type: none"> <li>■ Defect of compressor coil (disconnected, defective insulation)</li> <li>■ Compressor start-up malfunction (mechanical lock)</li> <li>■ Defect of inverter PC board</li> </ul>
<b>Troubleshooting</b>	Compressor inspection



**Caution**

Be sure to turn off power switch before connect or disconnect connector, or parts damage may be occurred.

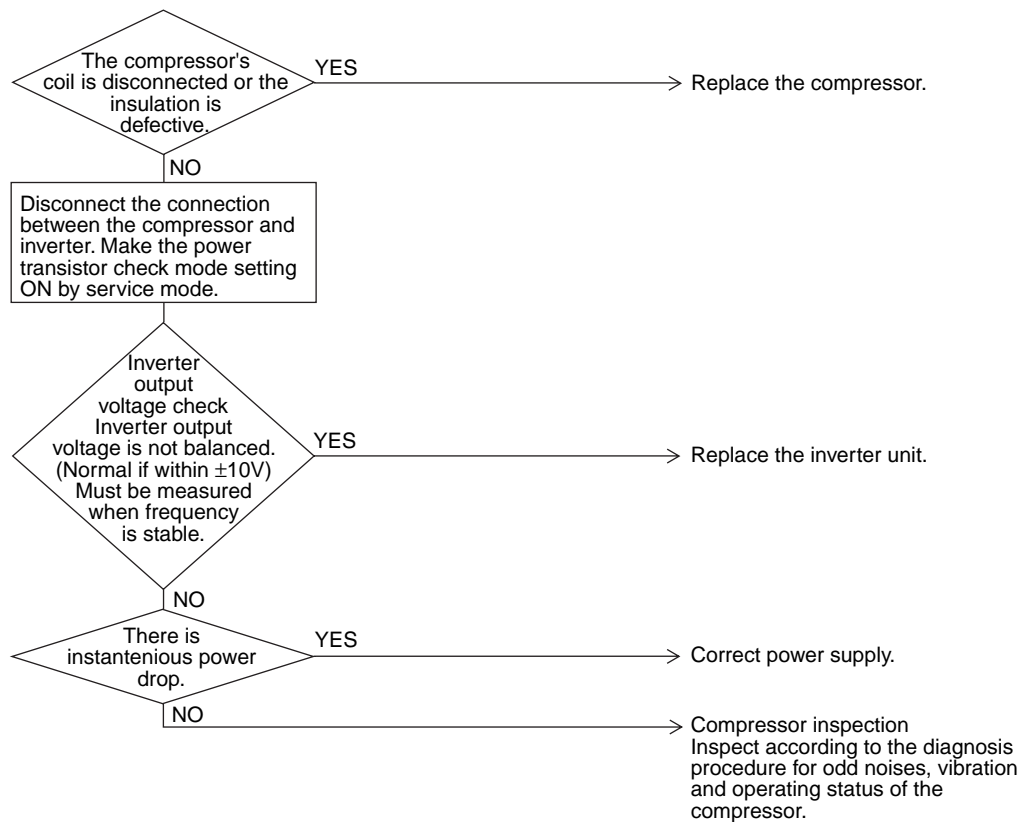

(V2812)

Higher voltage than actual is displayed when the inverter output voltage is checked by tester.

## 2.34 "L8" Outdoor Unit: Inverter Current Abnormal

Remote  
Controller  
Display

L8

Applicable  
Models

RXYQ5~48M

Method of  
Malfunction  
Detection

Malfunction is detected by current flowing in the power transistor.

Malfunction  
Decision  
Conditions

When overload in the compressor is detected.

Supposed  
Causes

- Compressor overload
- Compressor coil disconnected
- Defect of inverter PC board

Troubleshooting

Output current check



**Caution**

Be sure to turn off power switch before connect or disconnect connector, or parts damage may be occurred.

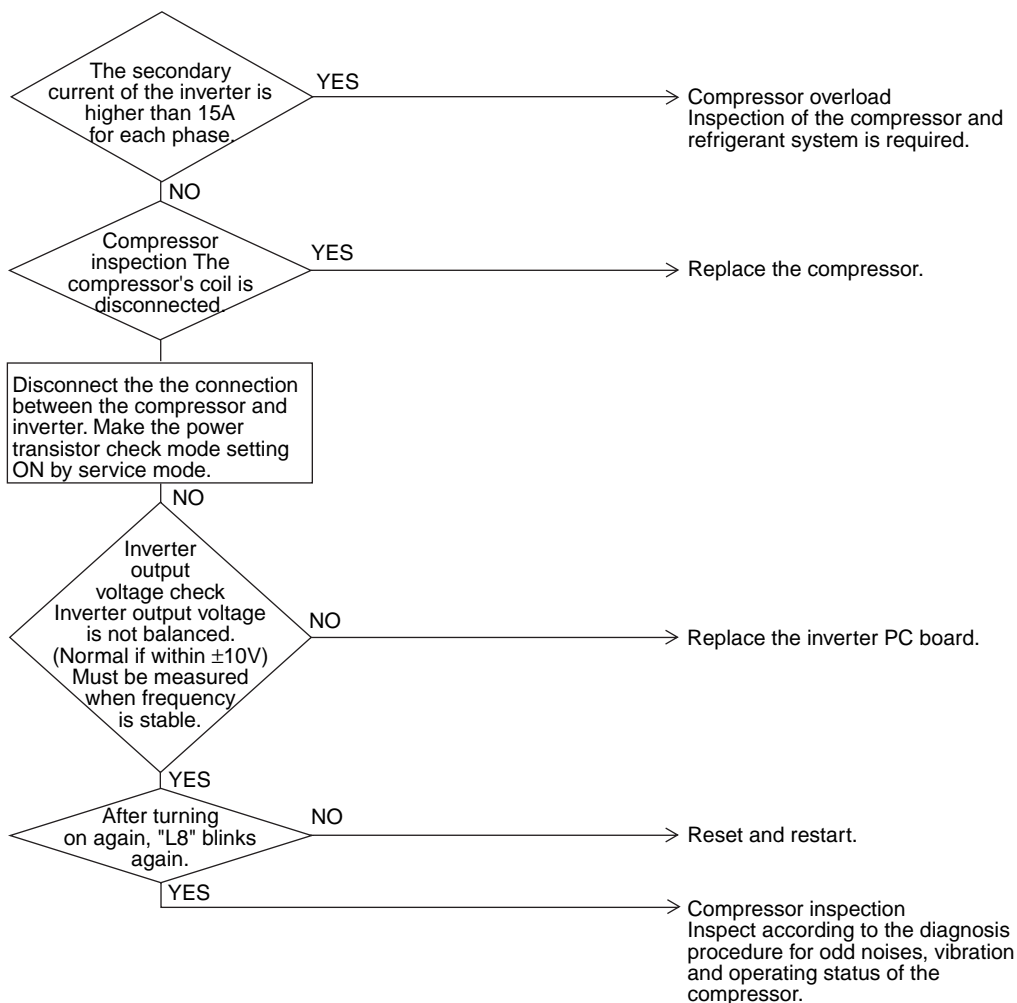

(V2813)

## 2.35 “L9” Outdoor Unit: Inverter Start up Error

<b>Remote Controller Display</b>	L9
<b>Applicable Models</b>	RXYQ5~48M
<b>Method of Malfunction Detection</b>	Malfunction is detected from current flowing in the power transistor.
<b>Malfunction Decision Conditions</b>	When overload in the compressor is detected during startup
<b>Supposed Causes</b>	<ul style="list-style-type: none"> <li>■ Defect of compressor</li> <li>■ Pressure differential start</li> <li>■ Defect of inverter PC board</li> </ul>

### Troubleshooting

 **Caution** Be sure to turn off power switch before connect or disconnect connector, or parts damage may be occurred.

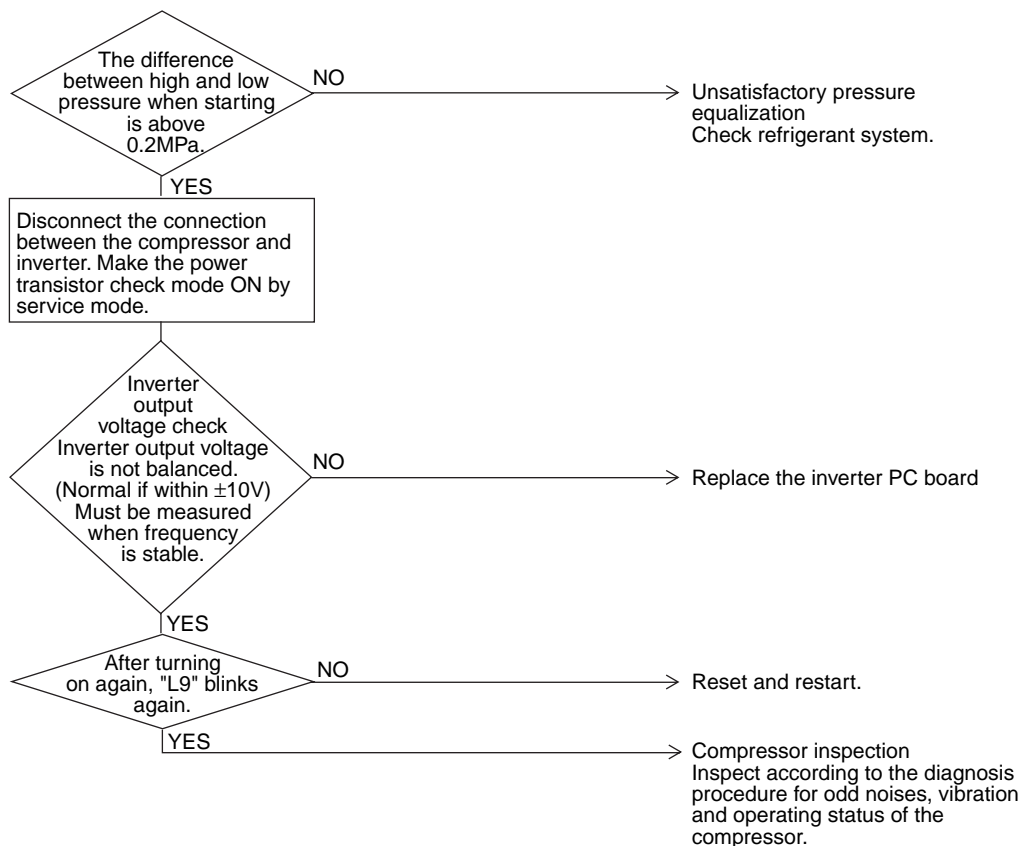

(V2814)

## 2.36 “LC” Outdoor Unit: Malfunction of Transmission Between Inverter and Control PC Board

<b>Remote Controller Display</b>	LC
<b>Applicable Models</b>	RXYQ5~48M
<b>Method of Malfunction Detection</b>	Check the communication state between inverter PC board and control PC board by micro-computer.
<b>Malfunction Decision Conditions</b>	When the correct communication is not conducted in certain period.
<b>Supposed Causes</b>	<ul style="list-style-type: none"> <li>■ Malfunction of connection between the inverter PC board and outdoor control PC board</li> <li>■ Defect of outdoor control PC board (transmission section)</li> <li>■ Defect of inverter PC board</li> <li>■ Defect of noise filter</li> <li>■ External factor (Noise etc.)</li> </ul>



Troubleshooting



**Caution**

Be sure to turn off power switch before connect or disconnect connector, or parts damage may be occurred.

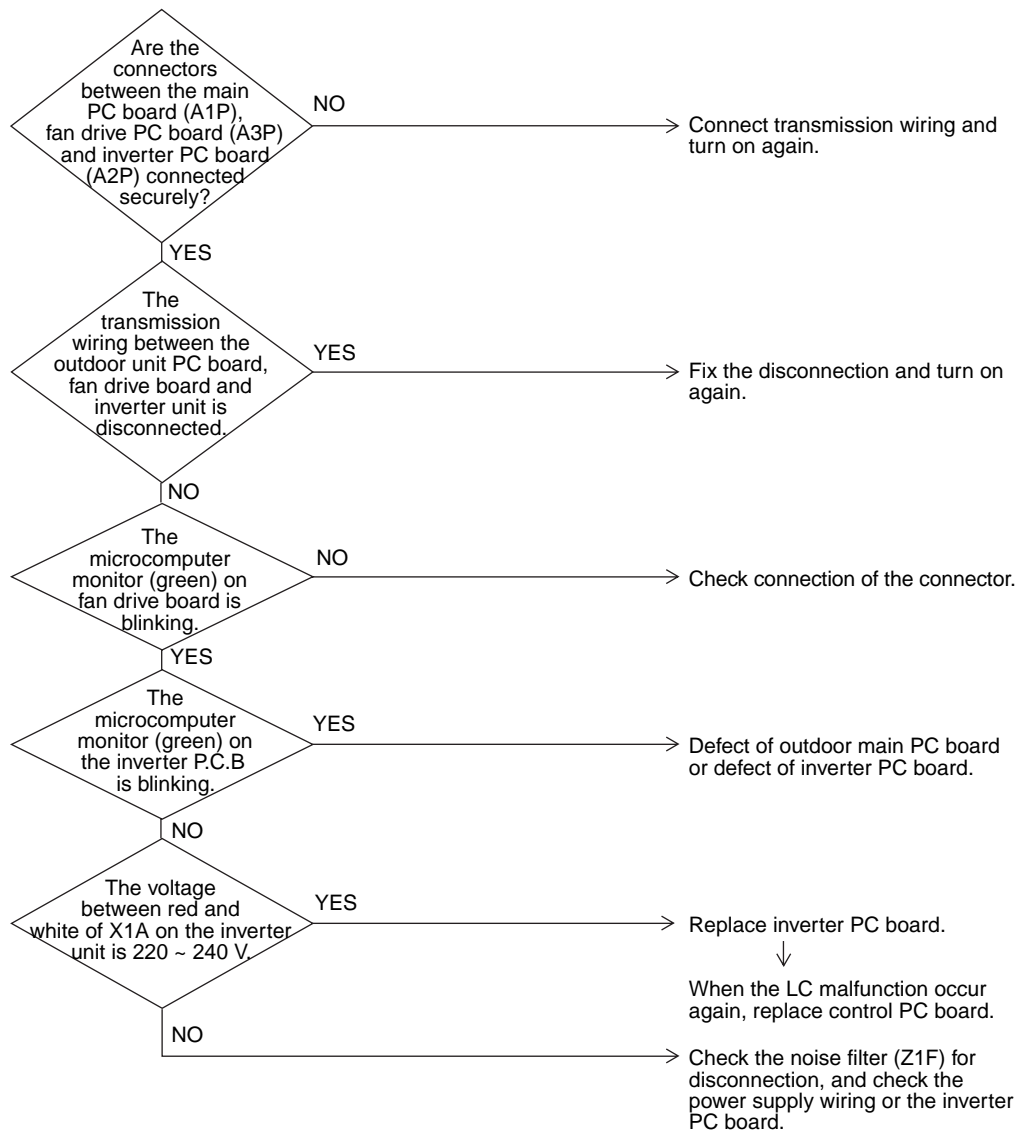

(V2815)

## 2.37 "P1" Outdoor Unit: Inverter Over-Ripple Protection

Remote  
Controller  
Display

P1

Applicable  
Models

RXYQ5~48M

Method of  
Malfunction  
Detection

Imbalance in supply voltage is detected in PC board.

Malfunction  
Decision  
Conditions

When the resistance value of thermistor becomes a value equivalent to open or short circuited status.

- Malfunction is not decided while the unit operation is continued.  
"P1" will be displayed by pressing the inspection button.

Supposed  
Causes

- Open phase
- Voltage imbalance between phases
- Defect of main circuit capacitor
- Defect of inverter PC board
- Defect of K1M
- Improper main circuit wiring

Troubleshooting

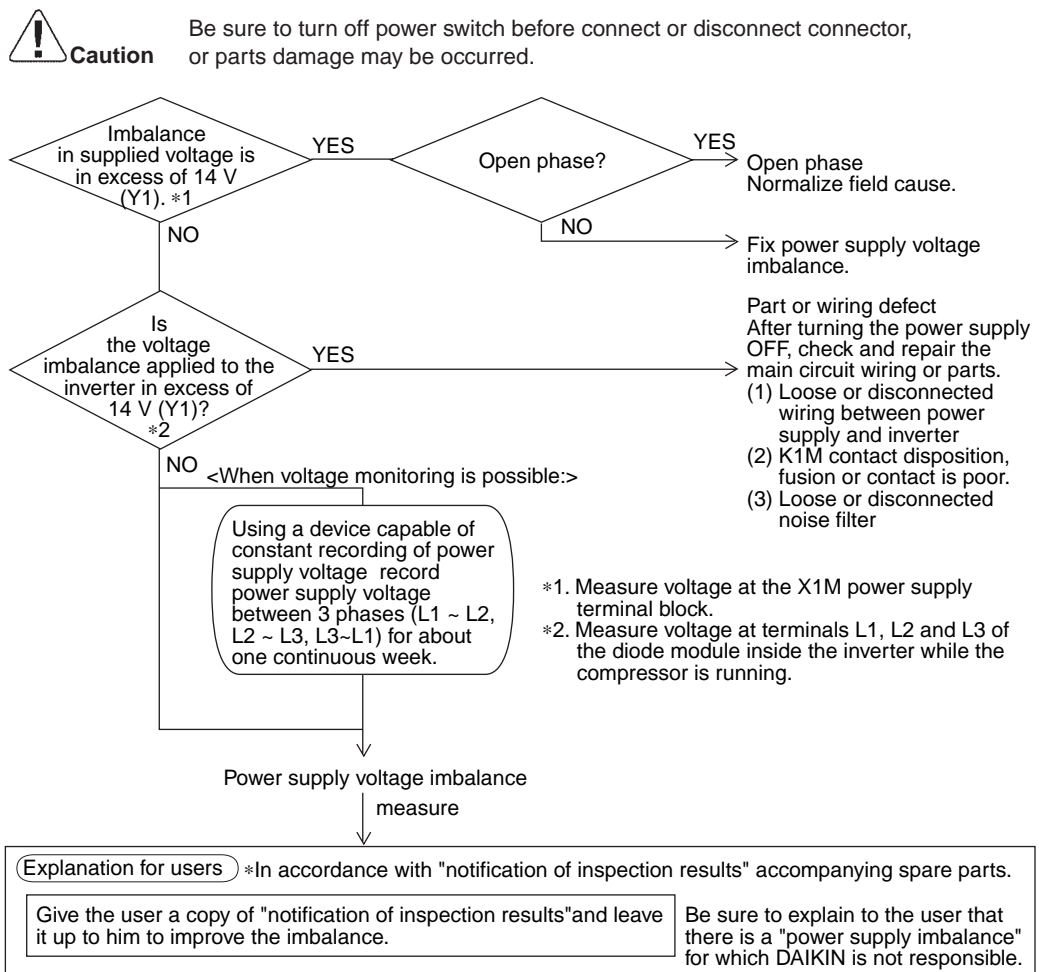

(V2816)

## 2.38 "P4" Outdoor Unit: Malfunction of Inverter Radiating Fin Temperature Rise Sensor

Remote Controller Display

P4

Applicable Models

RXYQ5~48M

Method of Malfunction Detection

Resistance of radiation fin thermistor is detected when the compressor is not operating.

Malfunction Decision Conditions

When the resistance value of thermistor becomes a value equivalent to open or short circuited status.

- Malfunction is not decided while the unit operation is continued.
- "P4" will be displayed by pressing the inspection button.

Supposed Causes

- Defect of radiator fin temperature sensor
- Defect of inverter PC board

Troubleshooting



**Caution**

Be sure to turn off power switch before connect or disconnect connector, or parts damage may be occurred.

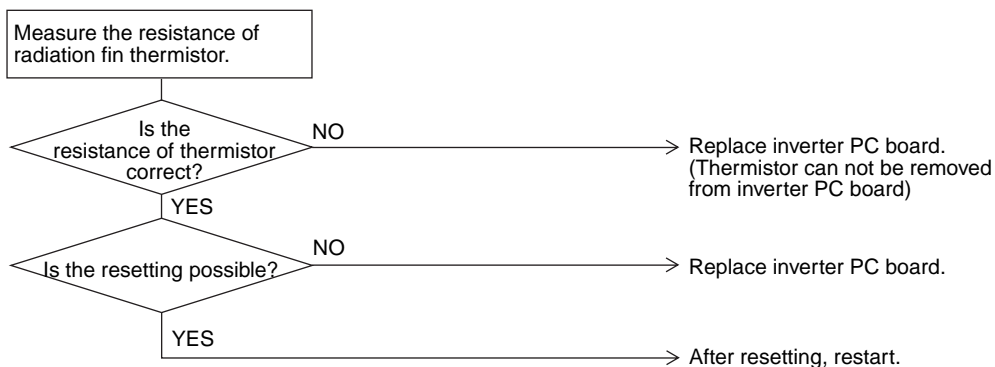

(V2818)



\*2: Refer to thermistor resistance / temperature characteristics table on P311.

## 2.39 “U0” Low Pressure Drop Due to Refrigerant Shortage or Electronic Expansion Valve Failure

Remote  
Controller  
Display

U0

Applicable  
Models

RXYQ5~48M

Method of  
Malfunction  
Detection

Short of gas malfunction is detected by discharge pipe temperature thermistor.

Malfunction  
Decision  
Conditions

Microcomputer judge and detect if the system is short of refrigerant.  
HM malfunction is not decided while the unit operation is continued.

Supposed  
Causes

- Out of gas or refrigerant system clogging (incorrect piping)
- Defect of pressure sensor
- Defect of outdoor unit PC board (A1P)
- Defect of thermistor R2T or R4T

### Troubleshooting



**Caution**

Be sure to turn off power switch before connect or disconnect connector, or parts damage may be occurred.

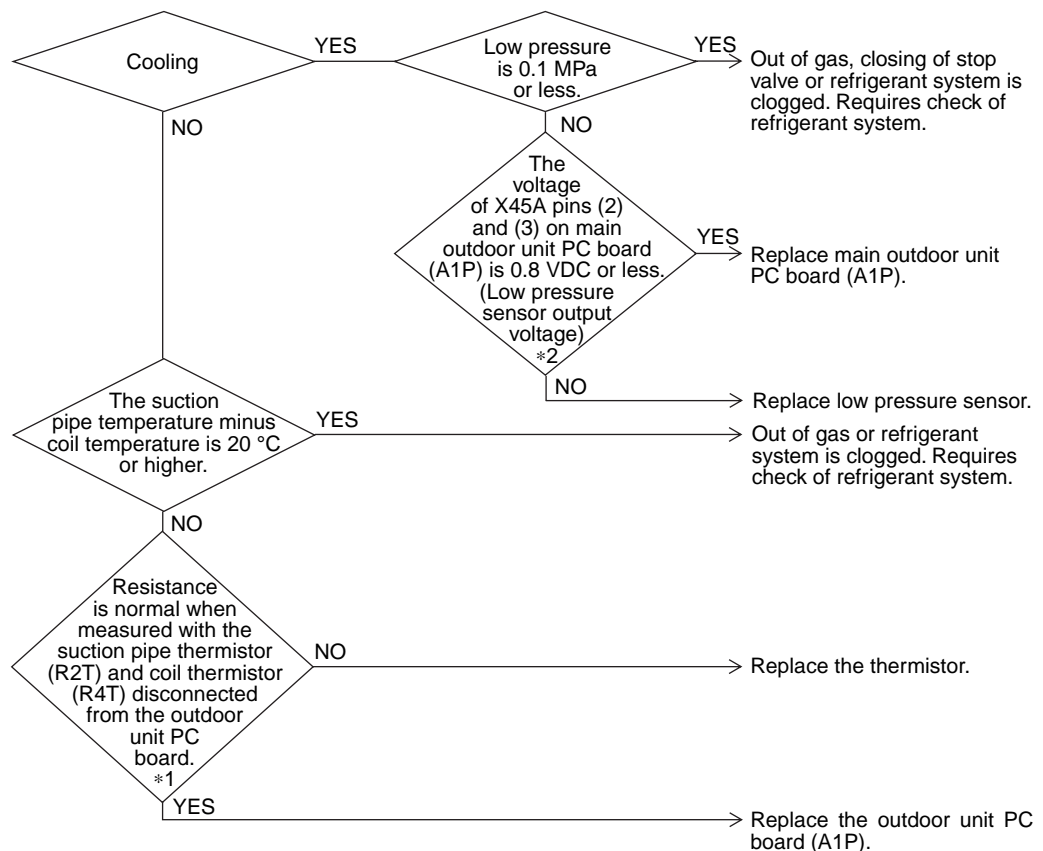

(V2819)



\*1: Refer to thermistor resistance / temperature characteristics table on P311.

\*2: Refer to pressure sensor, pressure / voltage characteristics table on P313.

## 2.40 “U1” Reverse Phase, Open Phase

Remote Controller Display

U1

Applicable Models

H3 phase outdoor unit only

Method of Malfunction Detection

Detection is based on the voltage in main circuit capacitor for inverter and supply voltage. The phase of each phase are detected by reverse phase detection circuit and right phase or reverse phase are judged.

Malfunction Decision Conditions

Supposed Causes

- Power supply reverse phase
- Power supply open phase
- Defect of outdoor PC board A1P

Troubleshooting



**Caution**

Be sure to turn off power switch before connect or disconnect connector, or parts damage may be occurred.

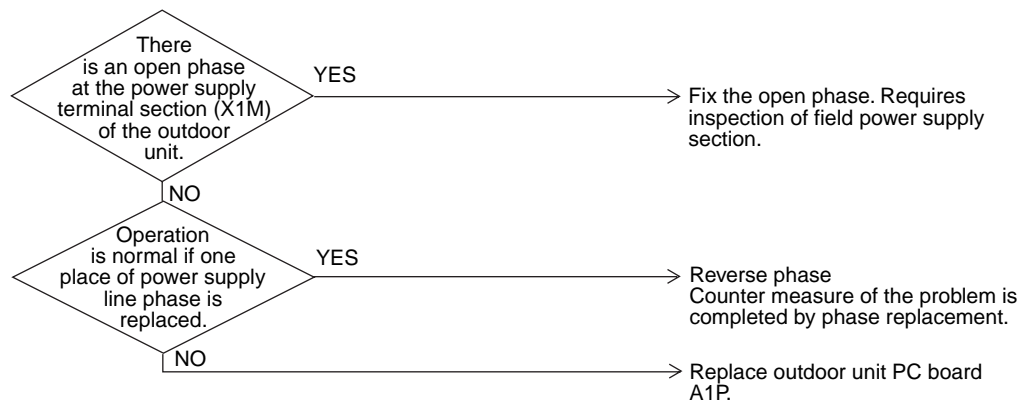

(V2820)

## 2.41 “U2” Power Supply Insufficient or Instantaneous Failure

Remote  
Controller  
Display

*U2*

Applicable  
Models

RXYQ5~48M

Method of  
Malfunction  
Detection

Detection of voltage of main circuit capacitor built in the inverter and power supply voltage.

Malfunction  
Decision  
Conditions

Supposed  
Causes

- Power supply insufficient
- Instantaneous failure
- Open phase
- Defect of inverter PC board
- Defect of outdoor control PC board
- Defect of K1M.
- Main circuit wiring defect

Troubleshooting



**Caution**

Be sure to turn off power switch before connect or disconnect connector, or parts damage may be occurred.

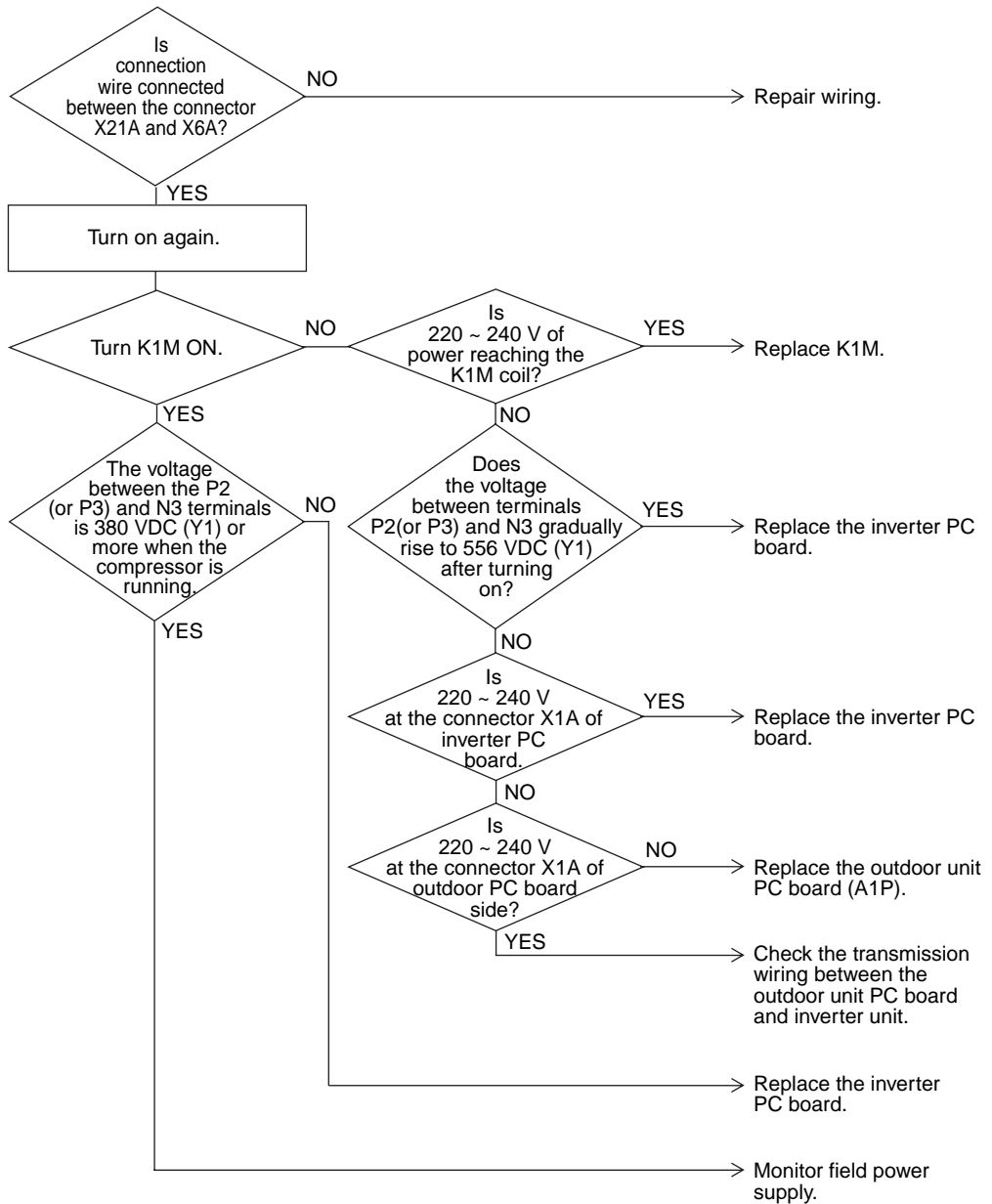

(V2821)

## 2.42 “U3” Check Operation not executed

Remote  
Controller  
Display

U3

Applicable  
Models

RXYQ5~48M

Method of  
Malfunction  
Detection

Check operation is executed or not

Malfunction  
Decision  
Conditions

Malfunction is decided when the unit starts operation without check operation.

Supposed  
Causes

- Check operation is not executed.

Troubleshooting



**Caution**

Be sure to turn off power switch before connect or disconnect connector, or parts damage may be occurred.

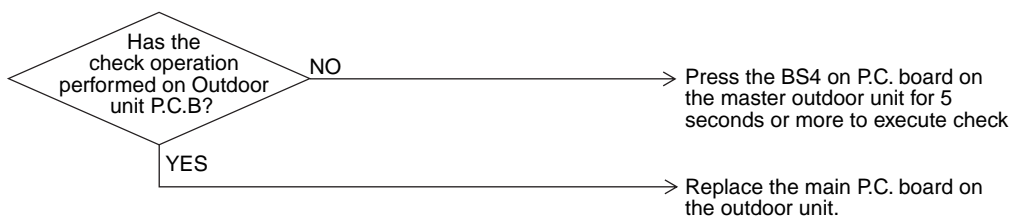

(V3052)



## 2.43 “U4” Malfunction of Transmission Between Indoor Units

Remote  
Controller  
Display

U4

Applicable  
Models

All model of indoor unit  
RXYQ5~48M

Method of  
Malfunction  
Detection

Microcomputer checks if transmission between indoor and outdoor units is normal.

Malfunction  
Decision  
Conditions

When transmission is not carried out normally for a certain amount of time

Supposed  
Causes

- Indoor to outdoor, outdoor to outdoor transmission wiring F1, F2 disconnection, short circuit or wrong wiring
- Outdoor unit power supply is OFF
- System address doesn't match
- Defect of indoor unit PC board
- Defect of outdoor unit PC board

Troubleshooting



**Caution** Be sure to turn off power switch before connect or disconnect connector, or parts damage may be occurred.

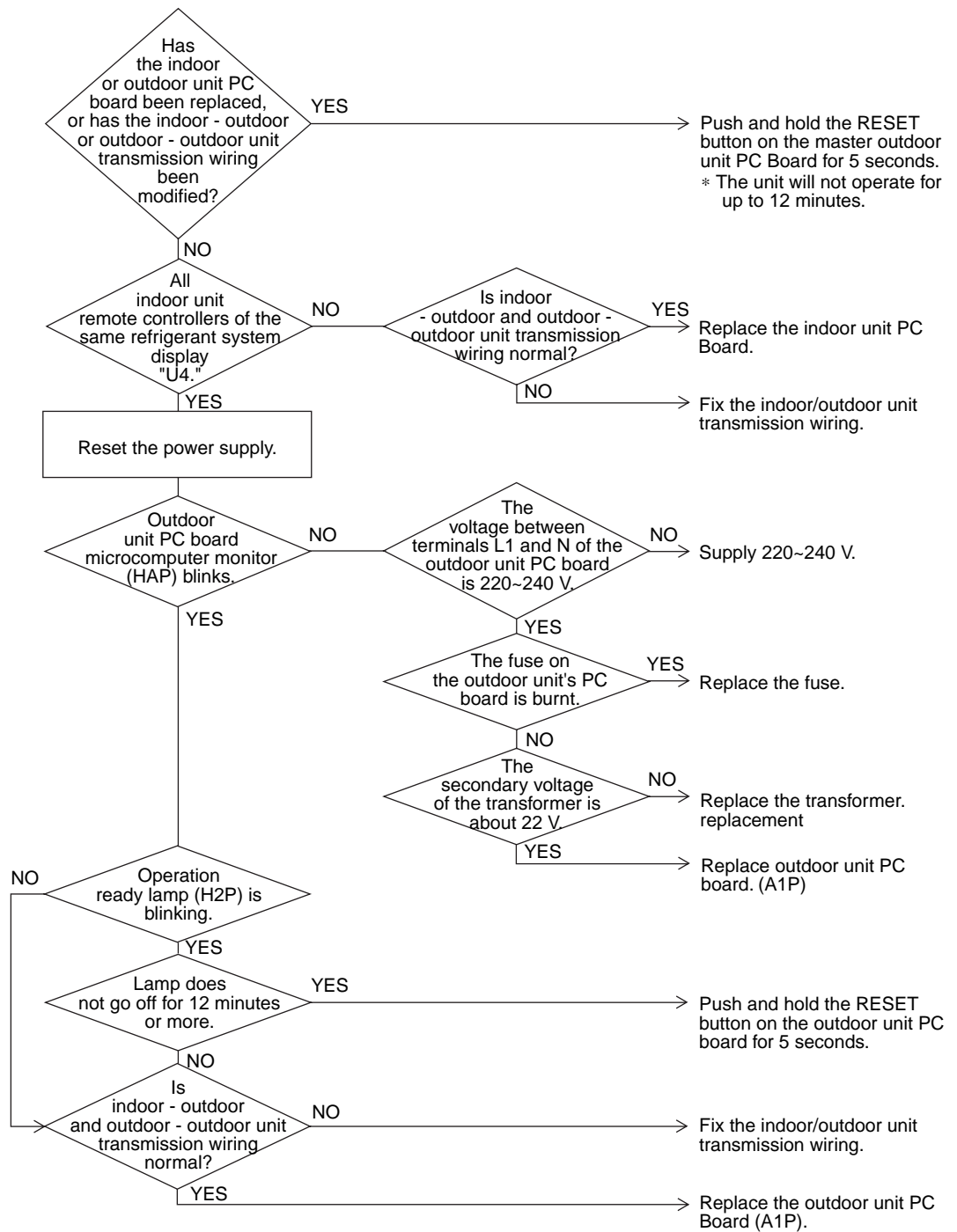

(V2822)

## 2.44 "U5" Malfunction of Transmission Between Remote Controller and Indoor Unit

Remote Controller Display

U5

Applicable Models

All models of indoor units

Method of Malfunction Detection

In case of controlling with 2-remote controller, check the system using microcomputer is signal transmission between indoor unit and remote controller (main and sub) is normal.

Malfunction Decision Conditions

Normal transmission does not continue for specified period.

Supposed Causes

- Malfunction of indoor unit remote controller transmission
- Connection of two main remote controllers (when using 2 remote controllers)
- Defect of indoor unit PC board
- Defect of remote controller PC board
- Malfunction of transmission caused by noise

### Troubleshooting



**Caution**

Be sure to turn off power switch before connect or disconnect connector, or parts damage may be occurred.

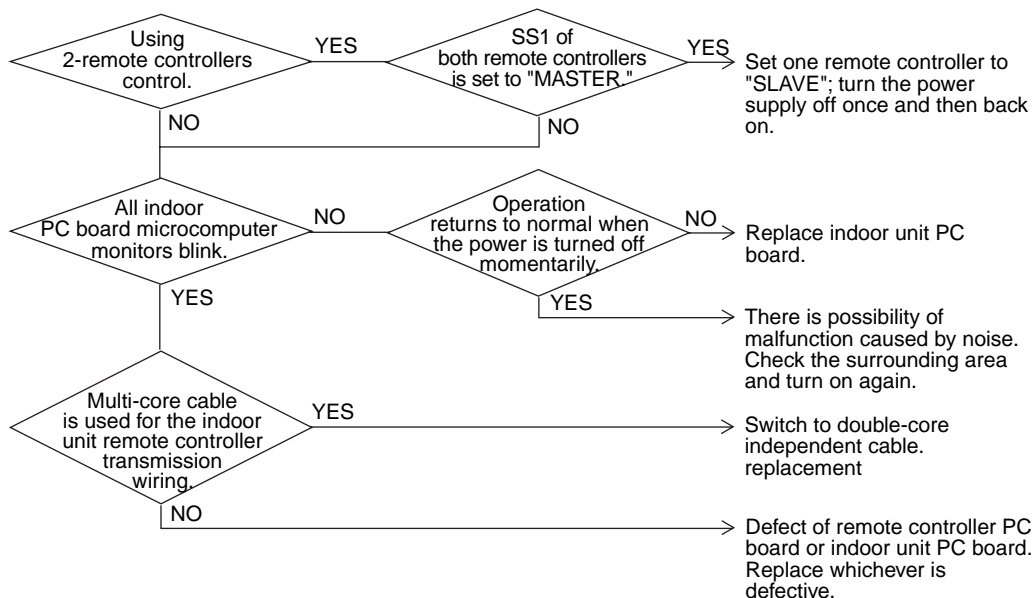

(V2823)

## 2.45 “U7” Malfunction of Transmission Between Outdoor Units

Remote  
Controller  
Display

U7

Applicable  
Models

All models of indoor units

Method of  
Malfunction  
Detection

Microcomputer checks if transmission between indoor unit and remote controller is normal.

Malfunction  
Decision  
Conditions

When transmission is not carried out normally for a certain amount of time

Supposed  
Causes

- Improper connection of transmission wiring between outdoor unit and outdoor unit outside control adaptor
- Improper cool/heat selection
- Improper cool/heat unified address (outdoor unit, external control adaptor for outdoor unit)
- Defect of outdoor unit PC board (A1P)
- Defect of outdoor unit outside control adaptor
- Improper connection of transmission wiring between outdoor units of multi outdoor unit connection.

Troubleshooting



**Caution**

Be sure to turn off power switch before connect or disconnect connector, or parts damage may be occurred.

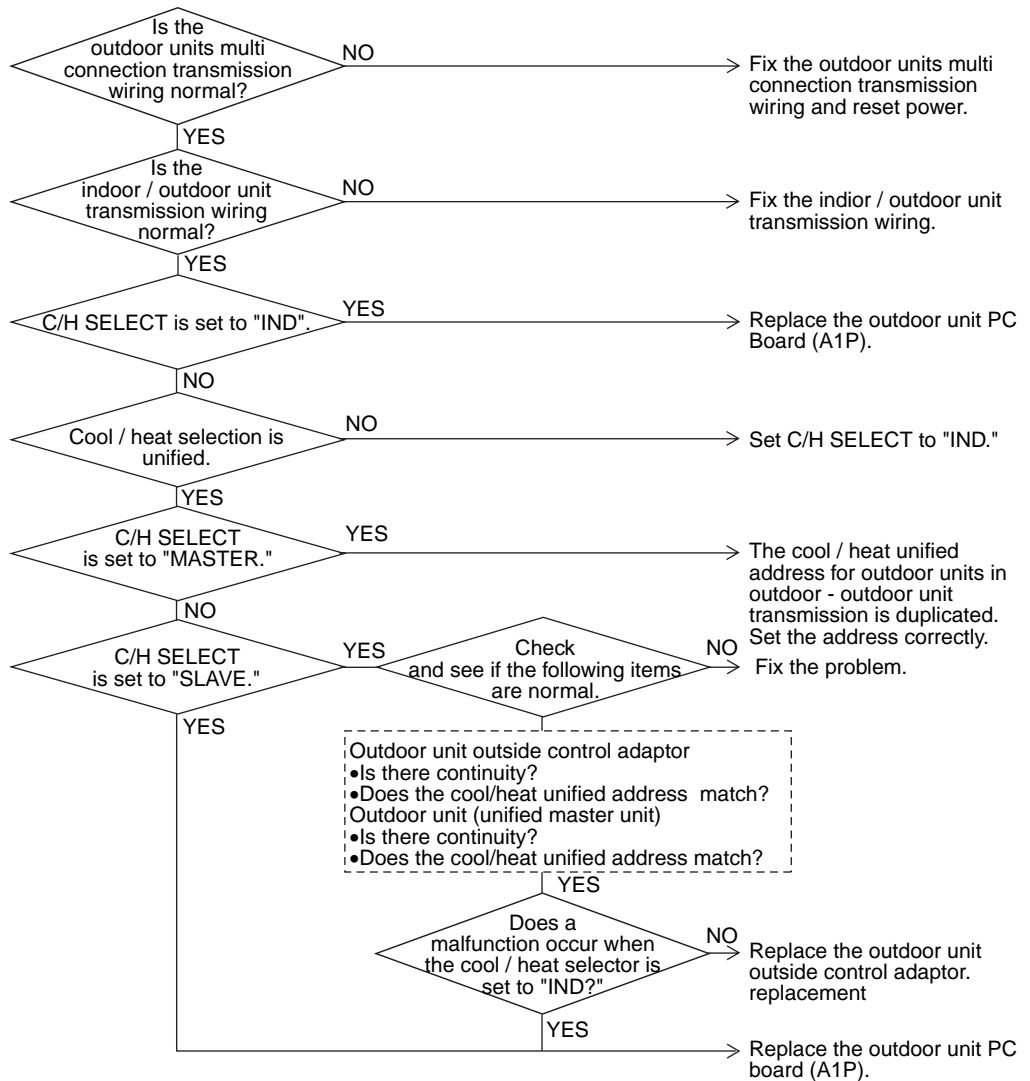

(V2824)

## 2.46 “UB” Malfunction of Transmission Between Master and Slave Remote Controllers

Remote  
Controller  
Display

UB

Applicable  
Models

All models of indoor units

Method of  
Malfunction  
Detection

In case of controlling with 2-remote controller, check the system using microcomputer if signal transmission between indoor unit and remote controller (main and sub) is normal.

Malfunction  
Decision  
Conditions

Normal transmission does not continue for specified period.

Supposed  
Causes

- Malfunction of transmission between main and sub remote controller
- Connection between sub remote controllers
- Defect of remote controller PC board

Troubleshooting



**Caution**

Be sure to turn off power switch before connect or disconnect connector, or parts damage may be occurred.

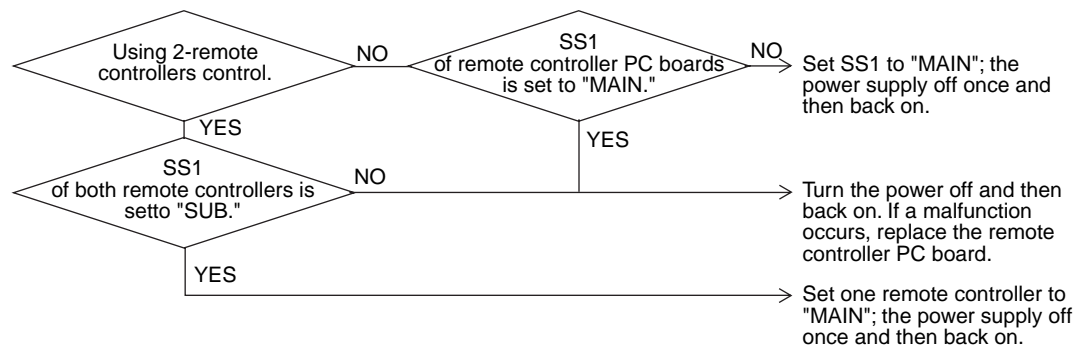

(V2825)

## 2.47 “U9” Malfunction of Transmission Between Indoor and Outdoor Units in the Same System

Remote  
Controller  
Display

*U9*

Applicable  
Models

All models of indoor units

Method of  
Malfunction  
Detection

Malfunction  
Decision  
Conditions

Supposed  
Causes

- Malfunction of transmission within or outside of other system
- Malfunction of electronic expansion valve in indoor unit of other system
- Defect of PC board of indoor unit in other system
- Improper connection of transmission wiring between indoor and outdoor unit

Troubleshooting

 **Caution** Be sure to turn off power switch before connect or disconnect connector, or parts damage may be occurred.

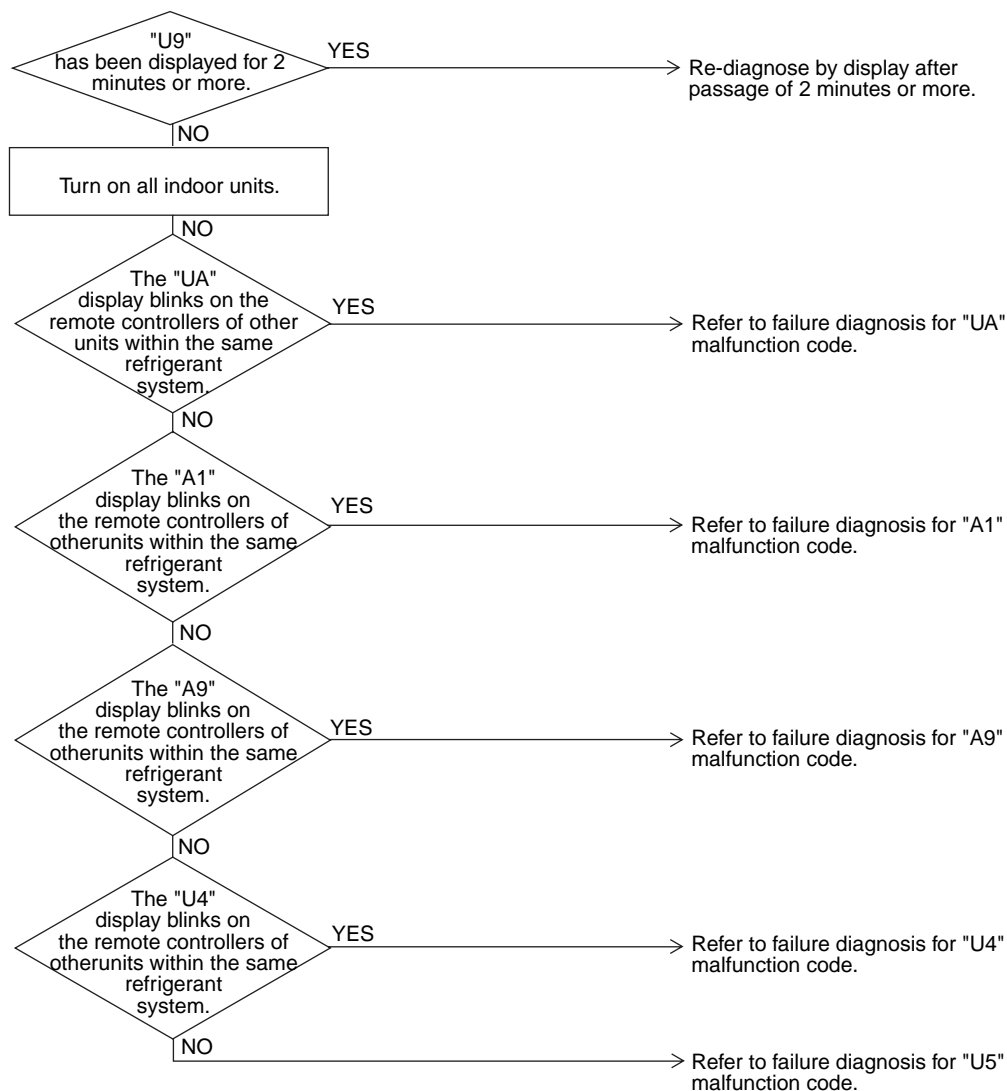

(V2826)



## 2.48 “UA” Excessive Number of Indoor Units

Remote Controller Display	UA
Applicable Models	All models of indoor unit RXYQ5~48M
Method of Malfunction Detection	
Malfunction Decision Conditions	
Supposed Causes	<ul style="list-style-type: none"> <li>■ Excess of connected indoor units</li> <li>■ Defect of outdoor unit PC board (A1P)</li> <li>■ Mismatching of the refrigerant type of indoor and outdoor unit.</li> <li>■ Setting of outdoor P.C. board was not conducted after replacing to spare parts P.C. board.</li> </ul>

### Troubleshooting



**Caution**

Be sure to turn off power switch before connect or disconnect connector, or parts damage may be occurred.

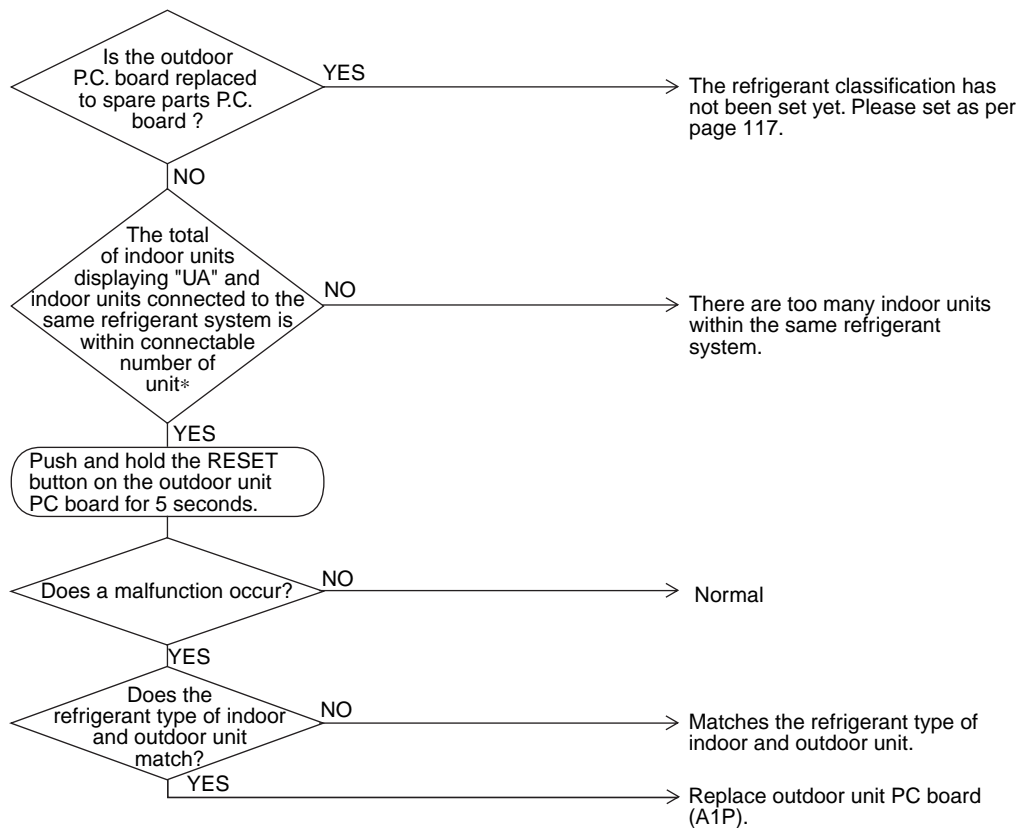

(V2827)

\* The number of indoor units that can be connected to a single outdoor unit system depends on the type of outdoor unit.

## 2.49 “UC” Address Duplication of Central Remote Controller

Remote  
Controller  
Display

UC

Applicable  
Models

All models of indoor unit  
Centralized controller

Method of  
Malfunction  
Detection

Malfunction  
Decision  
Conditions

Supposed  
Causes

- Address duplication of centralized remote controller
- Defect of indoor unit PC board

Troubleshooting



**Caution**

Be sure to turn off power switch before connect or disconnect connector, or parts damage may be occurred.

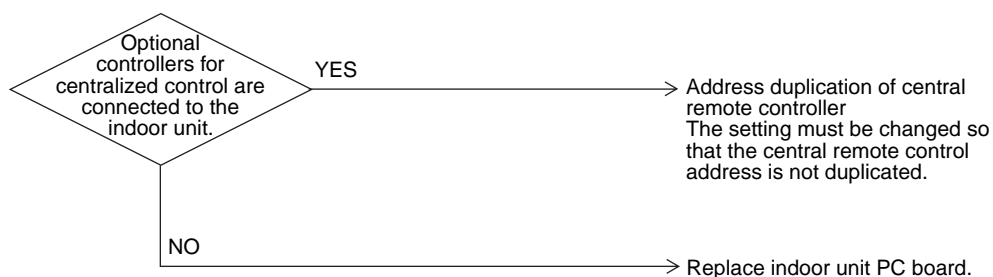

(V2828)

## 2.50 “UE” Malfunction of Transmission Between Central Remote Controller and Indoor Unit

<b>Remote Controller Display</b>	<i>UE</i>
<b>Applicable Models</b>	All models of indoor units Centralized controller
<b>Method of Malfunction Detection</b>	Microcomputer checks if transmission between indoor unit and centralized remote controller is normal.
<b>Malfunction Decision Conditions</b>	When transmission is not carried out normally for a certain amount of time
<b>Supposed Causes</b>	<ul style="list-style-type: none"> <li>■ Malfunction of transmission between optional controllers for centralized control and indoor unit</li> <li>■ Connector for setting master controller is disconnected.</li> <li>■ Failure of PC board for centralized remote controller</li> <li>■ Defect of indoor unit PC board</li> </ul>

Troubleshooting



**Caution**

Be sure to turn off power switch before connect or disconnect connector, or parts damage may be occurred.

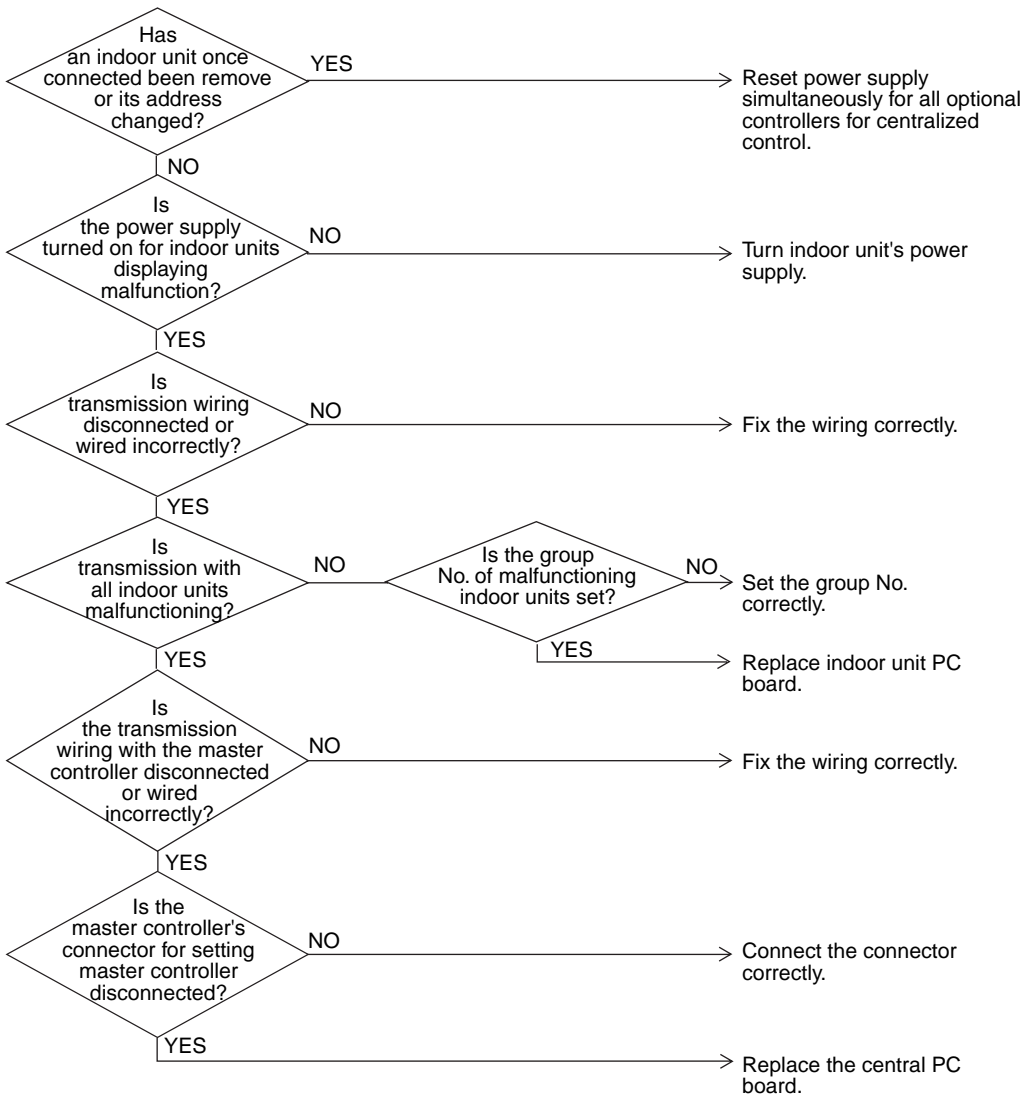

(V2829)

## 2.51 “UF” Refrigerant System not Set, Incompatible Wiring/ Piping

Remote Controller Display

UF

Applicable Models

All models of indoor units  
RXYQ5~48M

Method of Malfunction Detection

Malfunction Decision Conditions

Supposed Causes

- Improper connection of transmission wiring between outdoor unit and outdoor unit outside control adaptor
- Failure to execute wiring check operation
- Defect of indoor unit PC board

### Troubleshooting



**Caution**

Be sure to turn off power switch before connect or disconnect connector, or parts damage may be occurred.

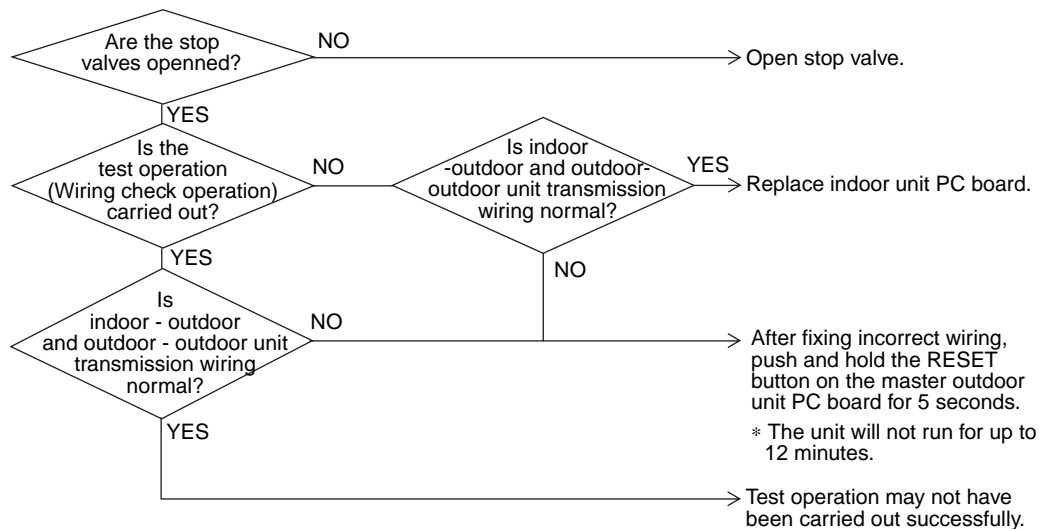

(V2830)



**Note:**

Test operation may not be successful if carried out after the outdoor unit has been off for more than 12 hours, or if it is not carried out after running all connected indoor units in the fan mode for at least an hour.

## 2.52 “UH” Malfunction of System, Refrigerant System Address Undefined

Remote Controller Display	UH
Applicable Models	All models of indoor units RXYQ5~48M
Method of Malfunction Detection	
Malfunction Decision Conditions	
Supposed Causes	<ul style="list-style-type: none"> <li>■ Improper connection of transmission wiring between outdoor unit and outdoor unit outside control adaptor</li> <li>■ Defect of indoor unit PC board</li> <li>■ Defect of outdoor unit PC board (A1P)</li> </ul>

### Troubleshooting

 **Caution** Be sure to turn off power switch before connect or disconnect connector, or parts damage may be occurred.

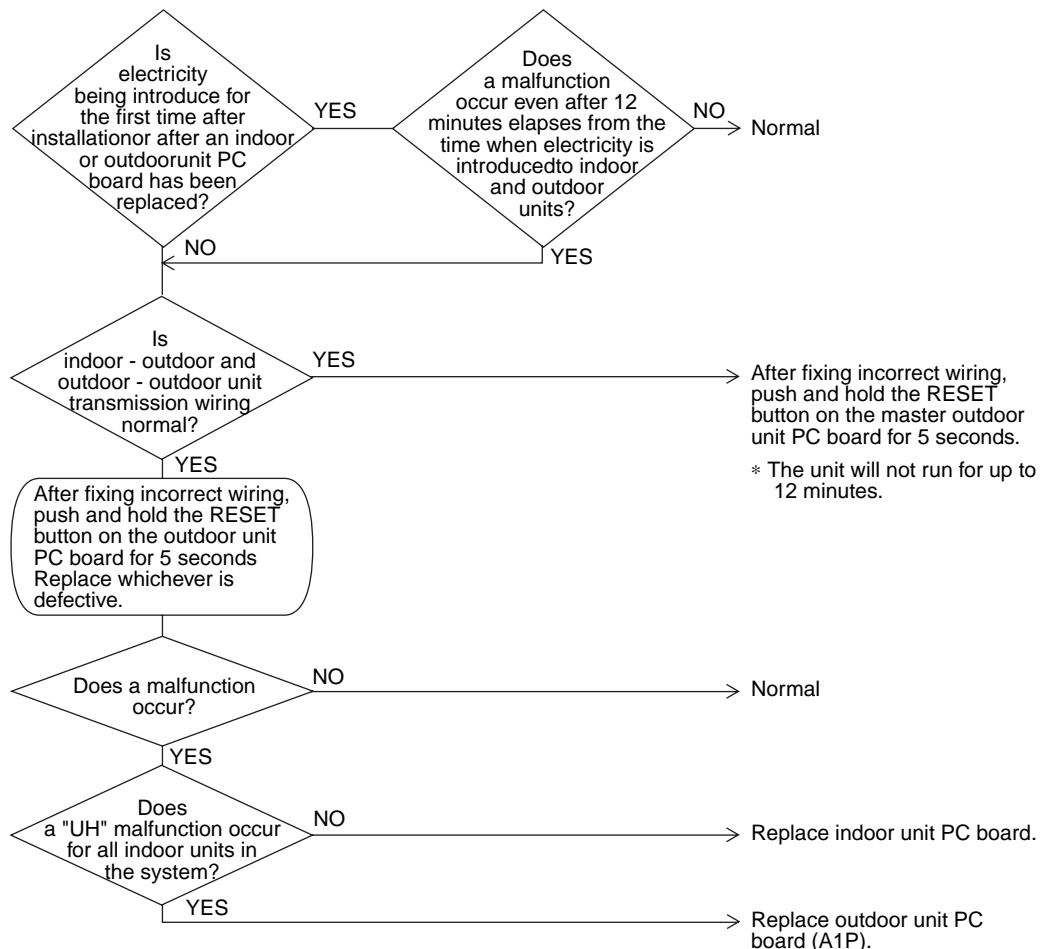

(V2831)

### 3. Troubleshooting (OP: Central Remote Controller)

#### 3.1 “UE” Malfunction of Transmission Between Central Remote Controller and Indoor Unit

<b>Remote Controller Display</b>	UE
<b>Applicable Models</b>	All models of indoor units RXYQ5~48M
<b>Method of Malfunction Detection</b>	Microcomputer checks if transmission between indoor unit and central remote controller is normal.
<b>Malfunction Decision Conditions</b>	When transmission is not carried out normally for a certain amount of time
<b>Supposed Causes</b>	<ul style="list-style-type: none"> <li>■ Malfunction of transmission between optional controllers for centralized control and indoor unit</li> <li>■ Connector for setting master controller is disconnected.</li> <li>■ Failure of PC board for central remote controller</li> <li>■ Defect of indoor unit PC board</li> </ul>

**Troubleshooting**

 **Caution** Be sure to turn off power switch before connect or disconnect connector, or parts damage may be occurred.

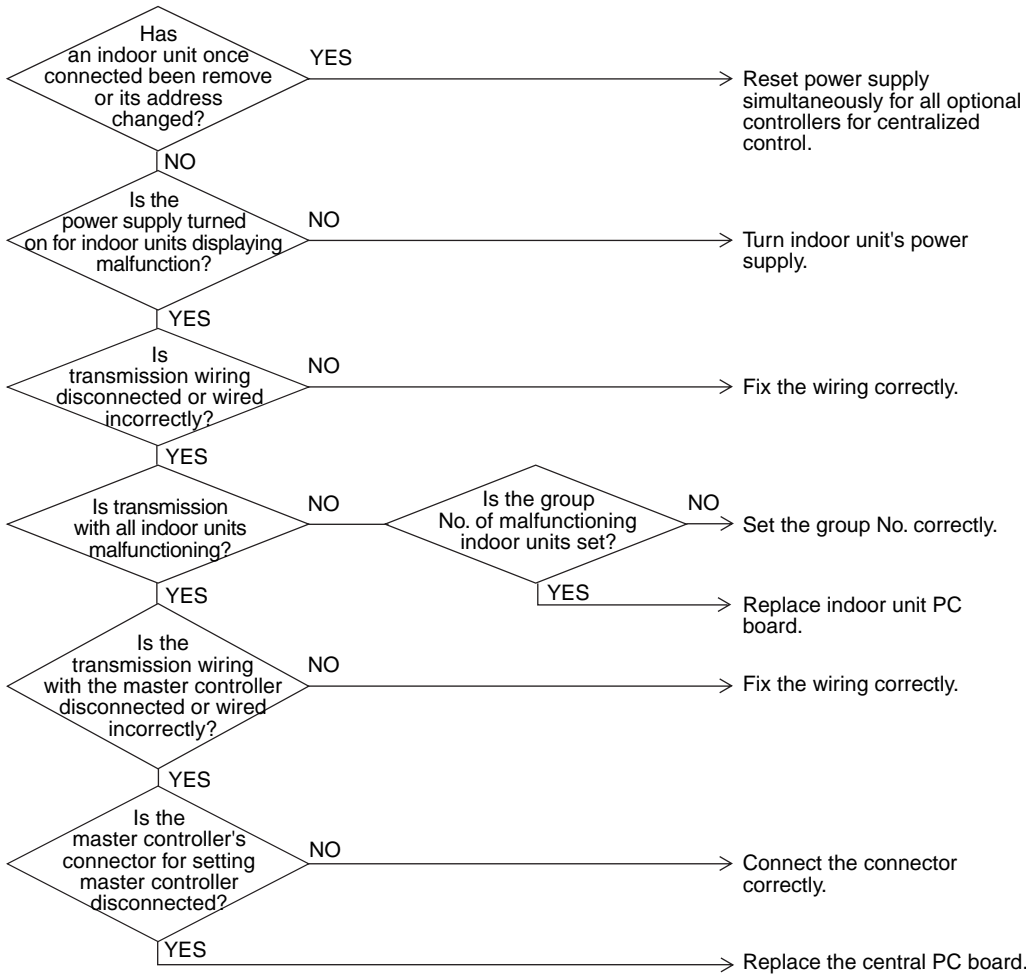

(V2832)

## 3.2 “E1” PC Board Defect

Remote  
Controller  
Display

E1

Applicable  
Models

Centralized remote controller

Method of  
Malfunction  
Detection

Malfunction  
Decision  
Conditions

Supposed  
Causes

- Defect of central remote controller PC board

Troubleshooting

Replace the central remote controller PC board.



### 3.3 “M8” Malfunction of Transmission Between Optional Controllers for Centralized Control

Remote Controller Display

M8

Applicable Models

Centralized remote controller

Method of Malfunction Detection

Malfunction Decision Conditions

Supposed Causes

- Malfunction of transmission between optional controllers for centralized control
- Defect of PC board of optional controllers for centralized control

Troubleshooting

 **Caution** Be sure to turn off power switch before connect or disconnect connector, or parts damage may be occurred.

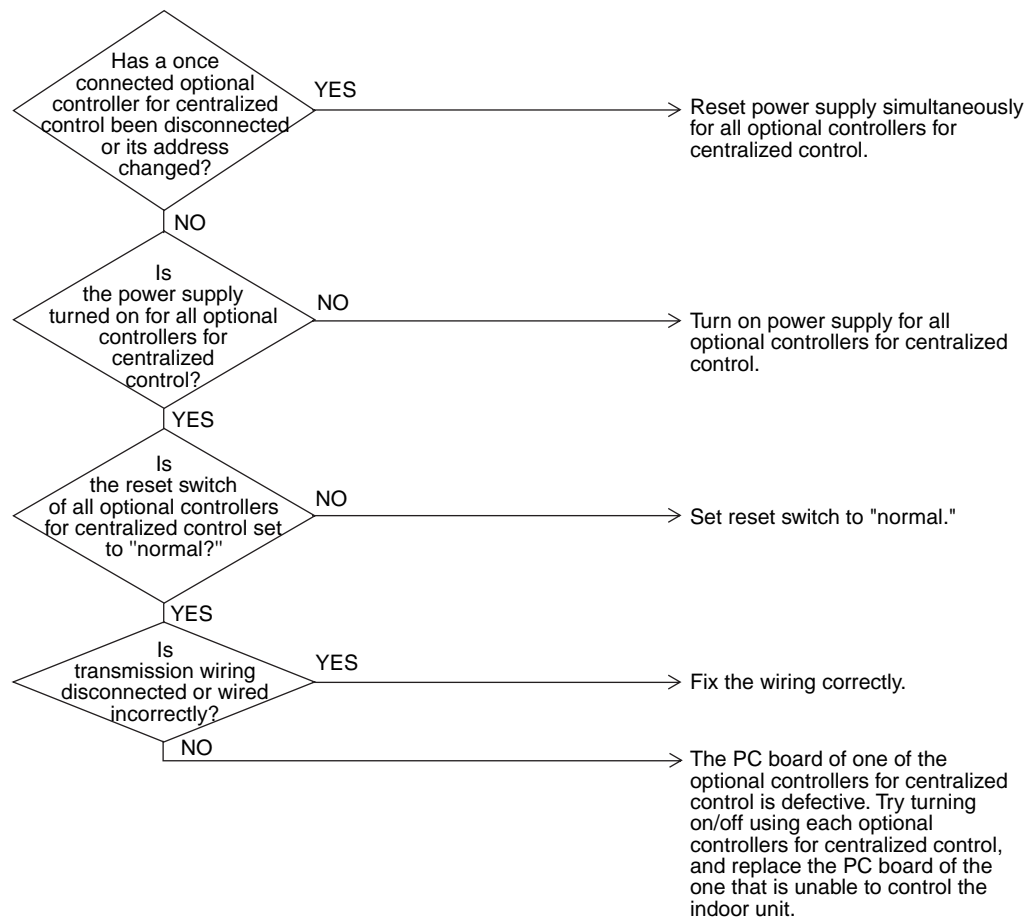

(V2833)

### 3.4 “*MR*” Improper Combination of Optional Controllers for Centralized Control

Remote  
Controller  
Display

---

*MR*

---

Applicable  
Models

Centralized remote controller

---

Method of  
Malfunction  
Detection

Malfunction  
Decision  
Conditions

Supposed  
Causes

- Improper combination of optional controllers for centralized control
- More than one master controller is connected
- Defect of PC board of optional controller for centralized control

Troubleshooting



**Caution**

Be sure to turn off power switch before connect or disconnect connector, or parts damage may be occurred.

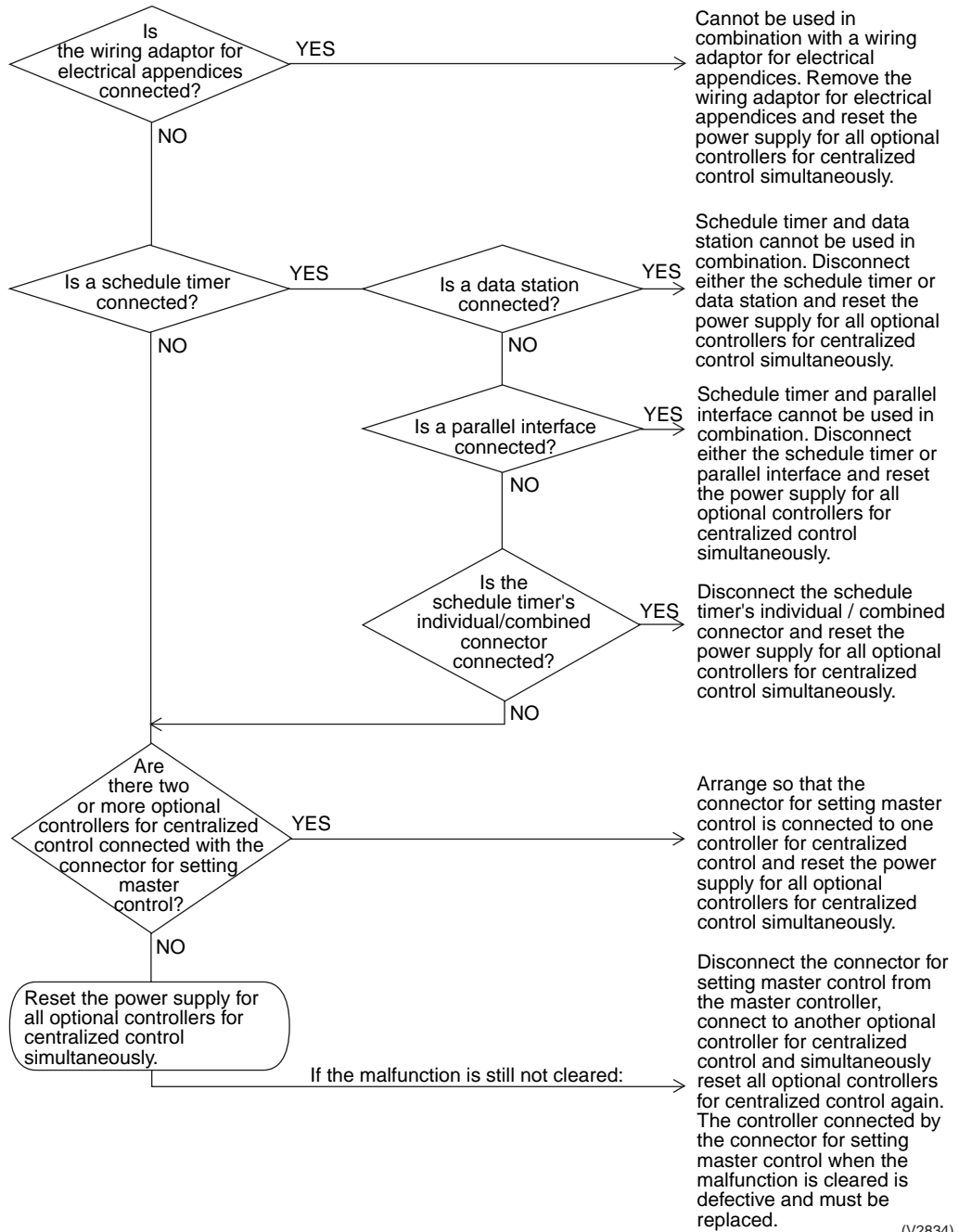

(V2834)

### 3.5 “MC” Address Duplication, Improper Setting

Remote Controller Display

MC

Applicable Models

Central remote controller

Method of Malfunction Detection

Malfunction Decision Conditions

Supposed Causes

- Address duplication of centralized remote controller

Troubleshooting



**Caution**

Be sure to turn off power switch before connect or disconnect connector, or parts damage may be occurred.

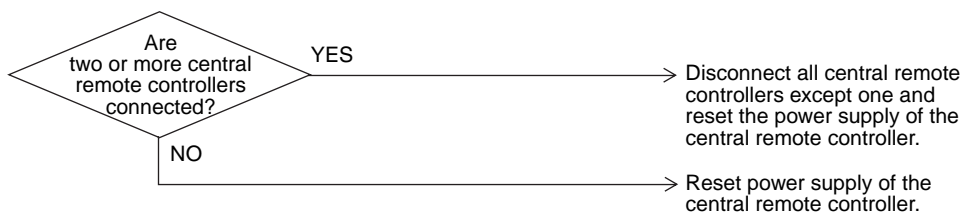

(V2835)

## 4. Troubleshooting (OP: Schedule Timer)

### 4.1 “UE” Malfunction of Transmission Between Central Remote Controller and Indoor Unit

<b>Remote Controller Display</b>	<i>UE</i>
<b>Applicable Models</b>	Schedule timer
<b>Method of Malfunction Detection</b>	Microcomputer checks if transmission between indoor unit and centralized remote controller is normal.
<b>Malfunction Decision Conditions</b>	When transmission is not carried out normally for a certain amount of time
<b>Supposed Causes</b>	<ul style="list-style-type: none"> <li>■ Malfunction of transmission between central remote controller and indoor unit</li> <li>■ Disconnection of connector for setting master controller (or individual/combined switching connector)</li> <li>■ Defect of schedule timer PC board</li> <li>■ Defect of indoor unit PC board</li> </ul>

Troubleshooting



**Caution**

Be sure to turn off power switch before connect or disconnect connector, or parts damage may be occurred.

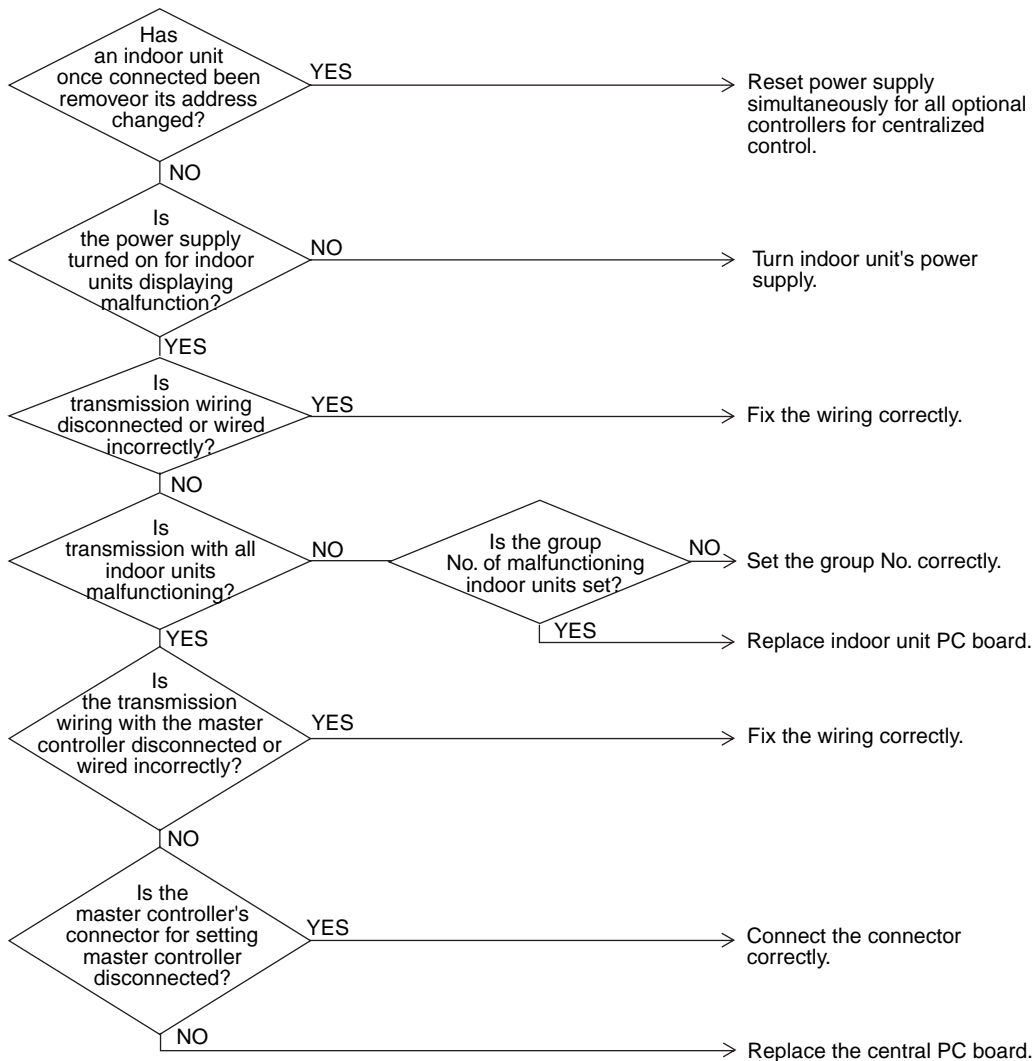

(V2836)

## 4.2 “E1” PC Board Defect

Remote  
Controller  
Display

E1

Applicable  
Models

Schedule timer

Method of  
Malfunction  
Detection

Malfunction  
Decision  
Conditions

Supposed  
Causes

- Defect of schedule timer PC board

Troubleshooting



**Caution**

Be sure to turn off power switch before connect or disconnect connector, or parts damage may be occurred.

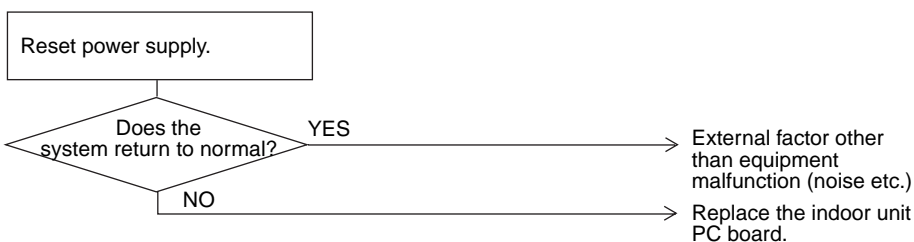

(V2837)

## 4.3 “M8” Malfunction of Transmission Between Optional Controllers for Centralized Control

Remote  
Controller  
Display

M8

Applicable  
Models

All models of indoor units, schedule timer

Method of  
Malfunction  
Detection

Malfunction  
Decision  
Conditions

Supposed  
Causes

- Malfunction of transmission between optional controllers for centralized control
- Defect of PC board of optional controllers for centralized control

Troubleshooting



**Caution**

Be sure to turn off power switch before connect or disconnect connector, or parts damage may be occurred.

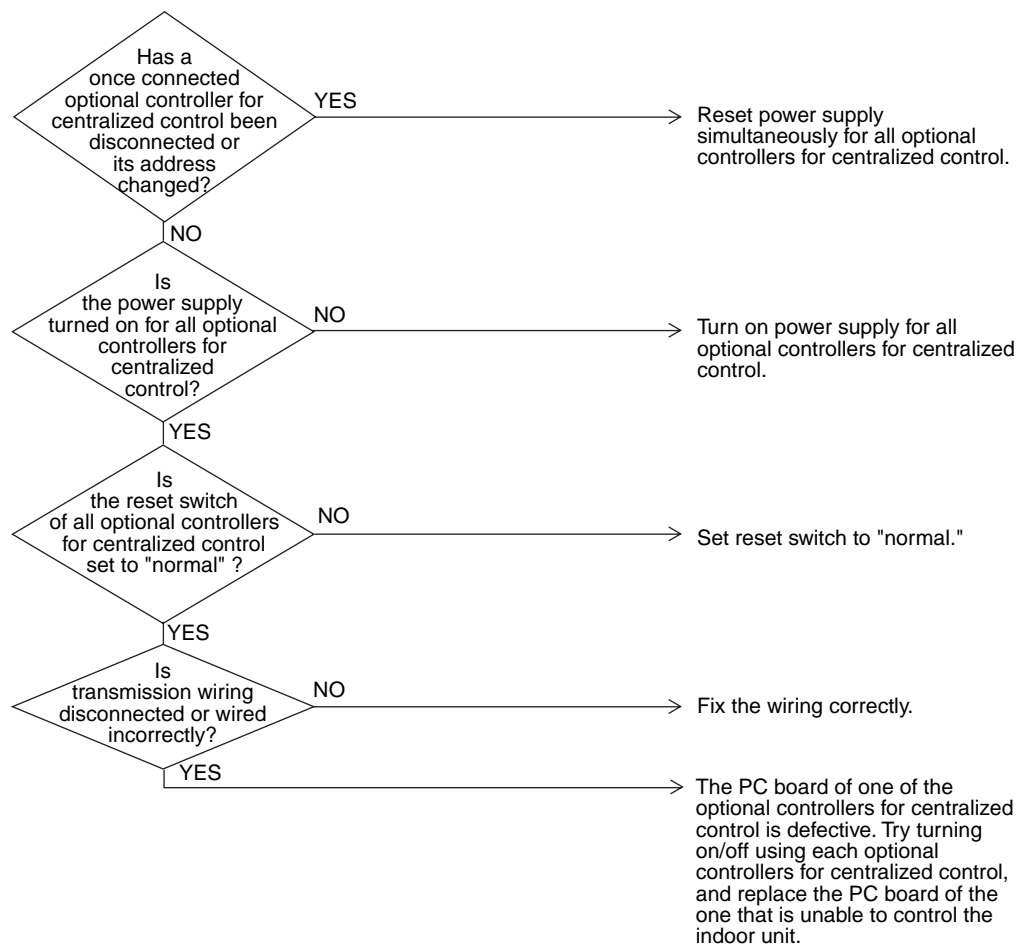

(V2838)



## 4.4 “*MR*” Improper Combination of Optional Controllers for Centralized Control

Remote  
Controller  
Display

*MR*

Applicable  
Models

All models of indoor units, schedule timer

Method of  
Malfunction  
Detection

Malfunction  
Decision  
Conditions

Supposed  
Causes

- Improper combination of optional controllers for centralized control
- More than one master controller is connected.
- Defect of PC board of optional controller for centralized control

Troubleshooting



**Caution**

Be sure to turn off power switch before connect or disconnect connector, or parts damage may be occurred.

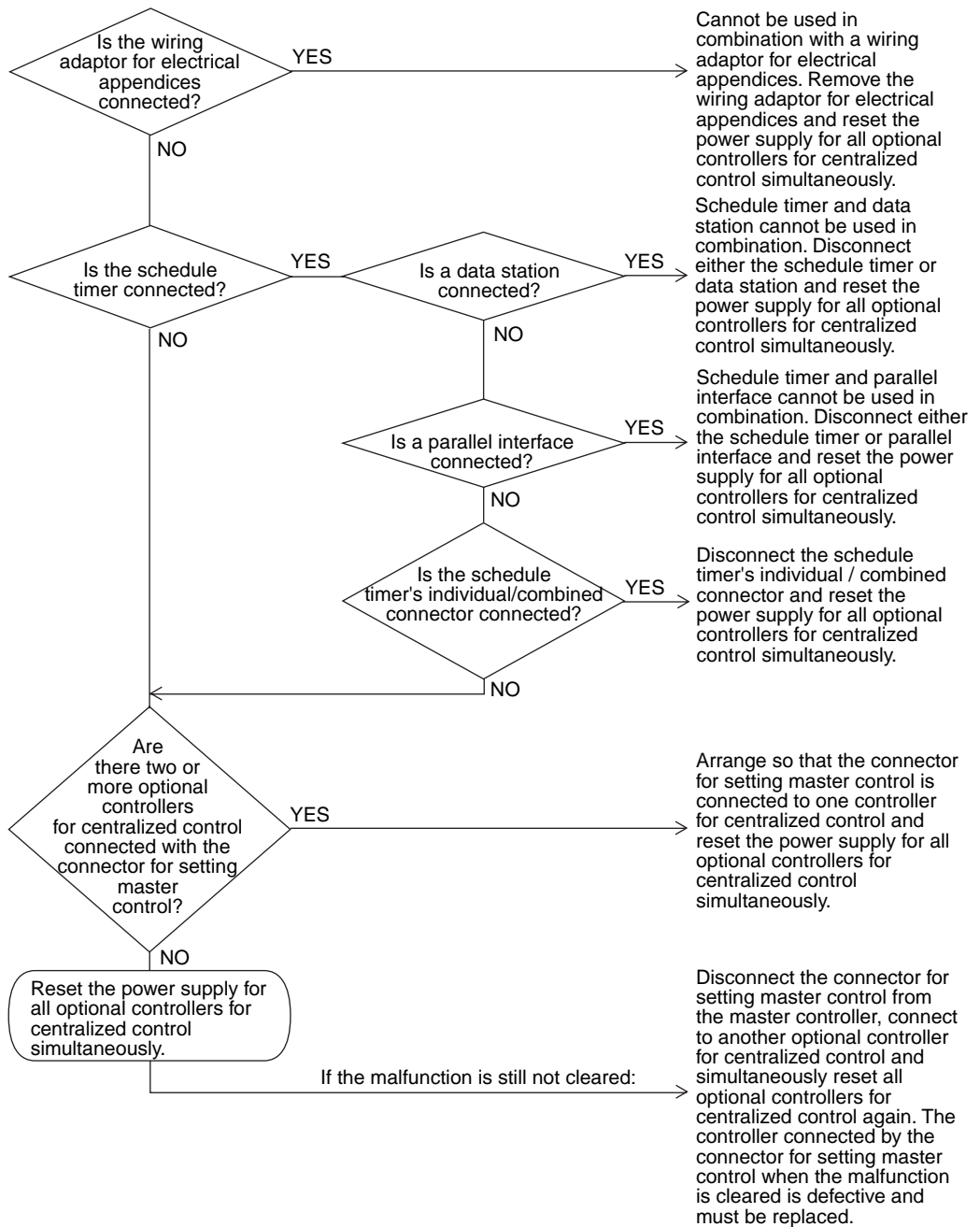

(V2839)

## 4.5 “MC” Address Duplication, Improper Setting

Remote  
Controller  
Display

MC

Applicable  
Models

All models of indoor units,  
schedule timer

Method of  
Malfunction  
Detection

Malfunction  
Decision  
Conditions

Supposed  
Causes

- Address duplication of optional controller for centralized control

Troubleshooting



**Caution**

Be sure to turn off power switch before connect or disconnect connector, or parts damage may be occurred.

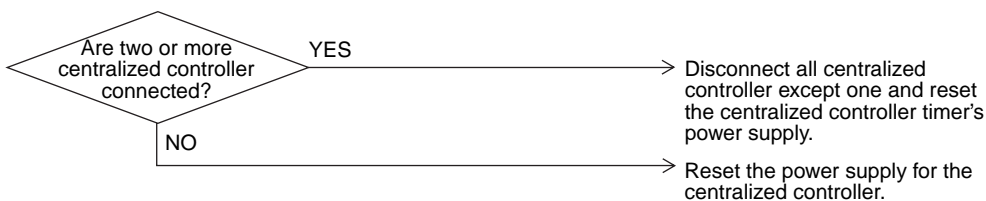

(V2840)

## 5. Troubleshooting (OP: Unified ON/OFF Controller)

### 5.1 Operation Lamp Blinks

---

**Remote  
Controller  
Display**

Operation lamp blinks

---

**Applicable  
Models**

All models of indoor units  
Unified ON/OFF controller

---

**Method of  
Malfunction  
Detection****Malfunction  
Decision  
Conditions****Supposed  
Causes**

- Malfunction of transmission between optional controller and indoor unit
- Connector for setting master controller is disconnected
- Defect of unified ON/OFF controller
- Defect of indoor unit PC board
- Malfunction of air conditioner

Troubleshooting



**Caution**

Be sure to turn off power switch before connect or disconnect connector, or parts damage may be occurred.

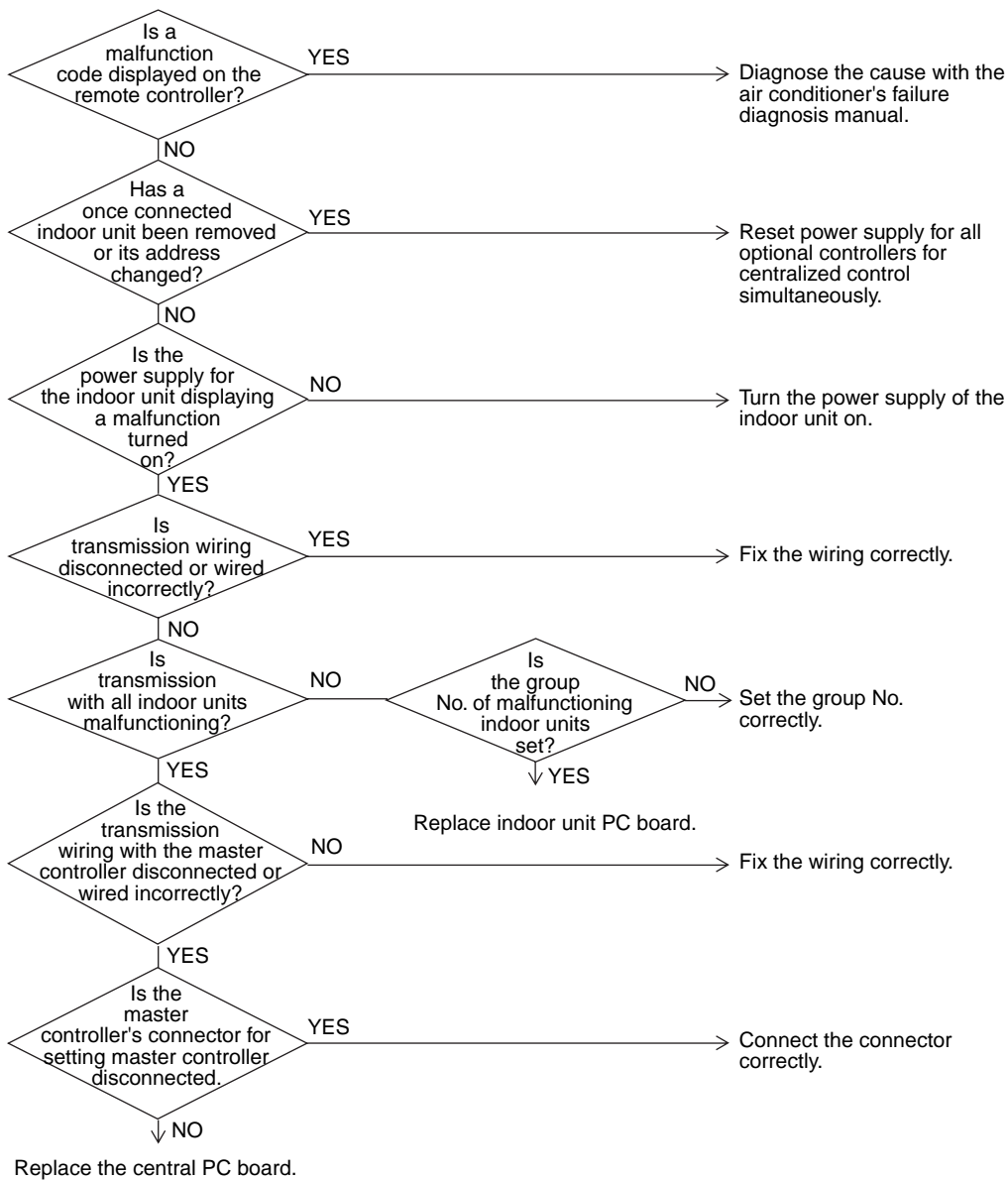

(V2841)

## 5.2 Display “Under Host Computer Integrate Control” Blinks (Repeats Single Blink)

---

**Remote Controller Display**

“under host computer integrated control” (Repeats single blink)

---

**Applicable Models**

Unified ON/OFF controller  
Central controller, Schedule timer

---

**Method of Malfunction Detection****Malfunction Decision Conditions**

---

**Supposed Causes**

- Address duplication of central remote controller
- Improper combination of optional controllers for centralized control
- Connection of more than one master controller
- Malfunction of transmission between optional controllers for centralized control
- Defect of PC board of optional controllers for centralized control

Troubleshooting



**Caution** Be sure to turn off power switch before connect or disconnect connector, or parts damage may be occurred.

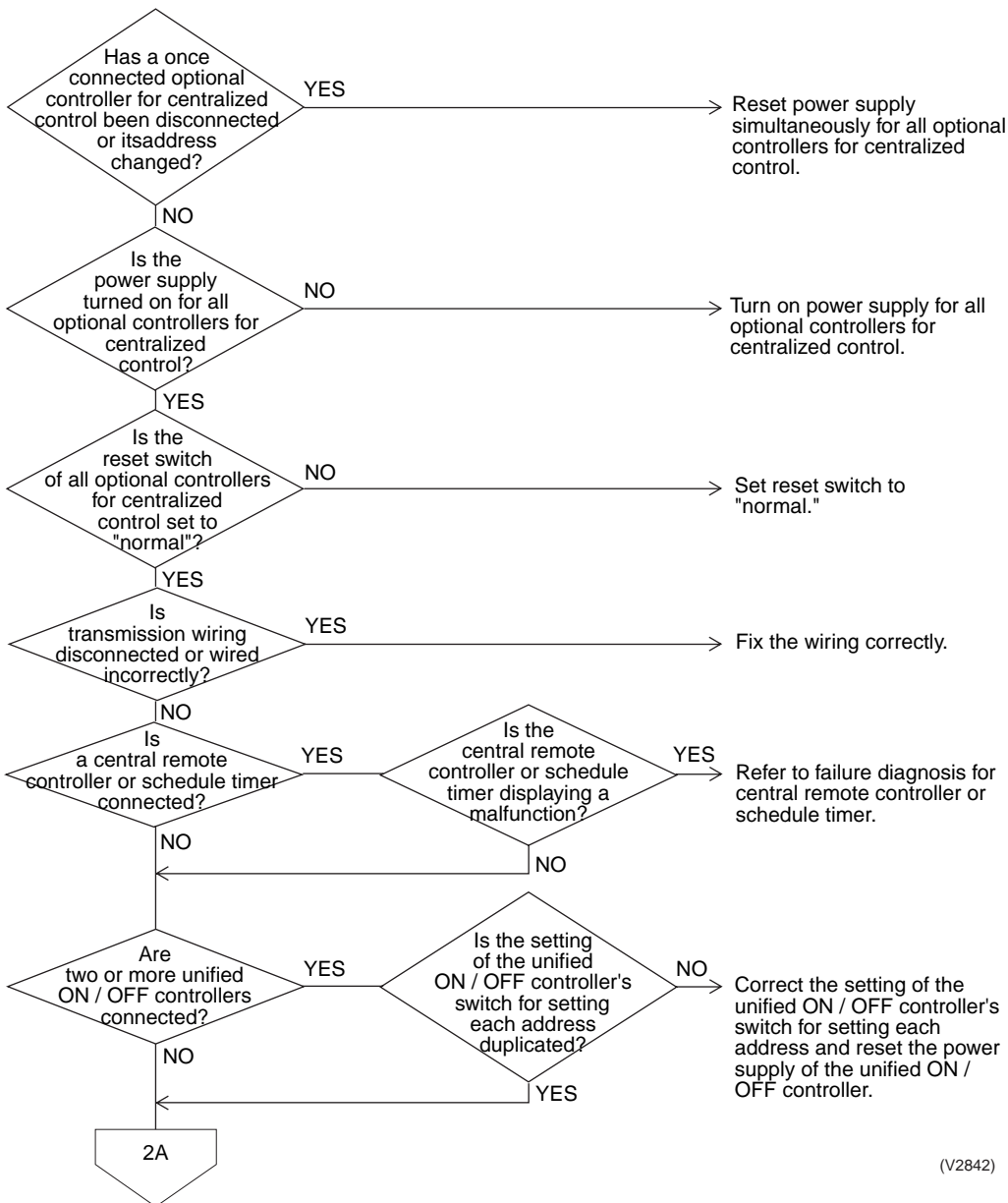

(V2842)

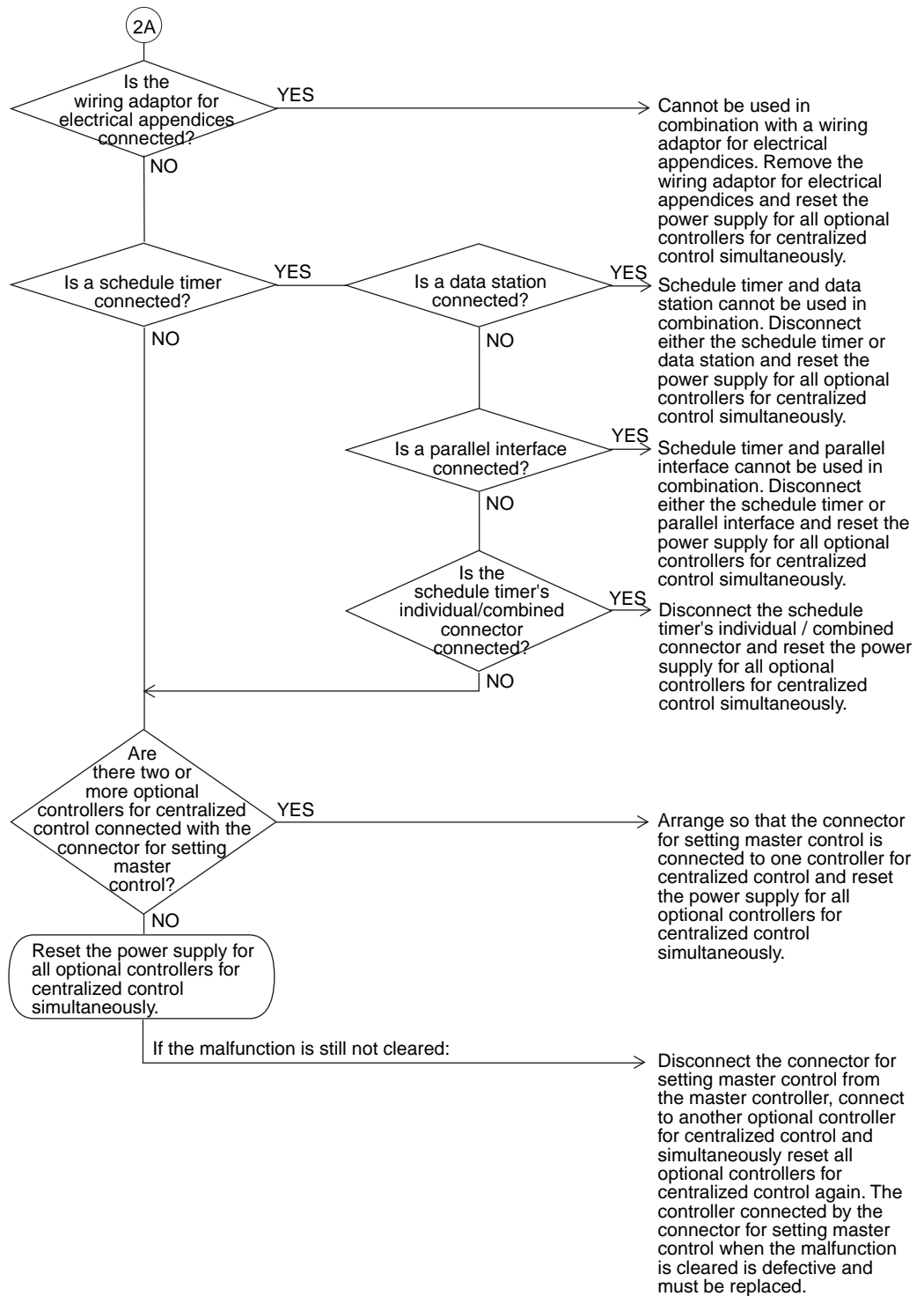

(V2843)



### 5.3 Display “Under Host Computer Integrate Control” Blinks (Repeats Double Blink)

<b>Remote Controller Display</b>	“under host computer integrated control” (Repeats double blink)
<b>Applicable Models</b>	Unified ON/OFF controller
<b>Method of Malfunction Detection</b>	
<b>Malfunction Decision Conditions</b>	
<b>Supposed Causes</b>	<ul style="list-style-type: none"> <li>■ Central control address (group No.) is not set for indoor unit.</li> <li>■ Improper address setting</li> <li>■ Improper wiring of transmission wiring</li> </ul>

**Troubleshooting**

 **Caution** Be sure to turn off power switch before connect or disconnect connector, or parts damage may be occurred.

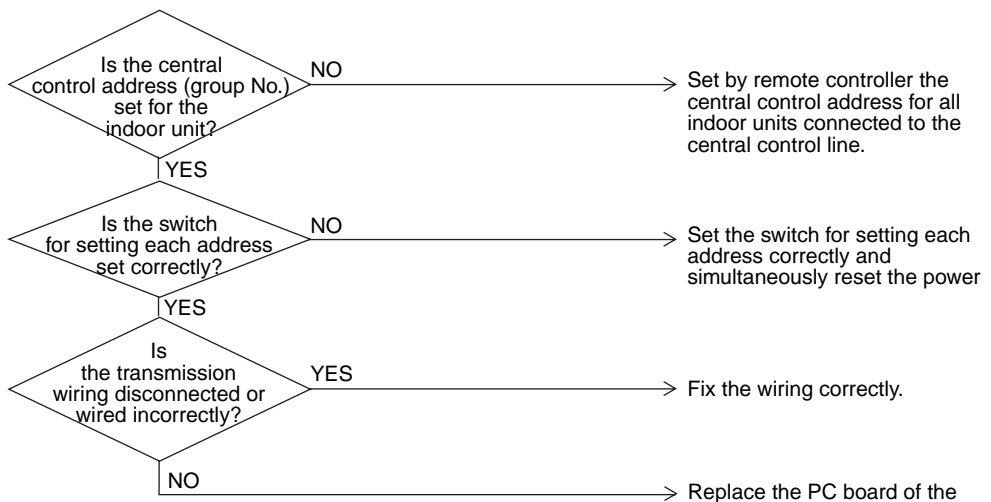

(V2844)

**Check No. 8****Check on connector of fan motor (Power supply cable)**

(1) Turn off the power supply.

Measure the resistance between phases of U,V,W at the motor side connectors (three-core wire) to check that the values are balanced and there is no short circuiting, while connector or relay connector is disconnected.

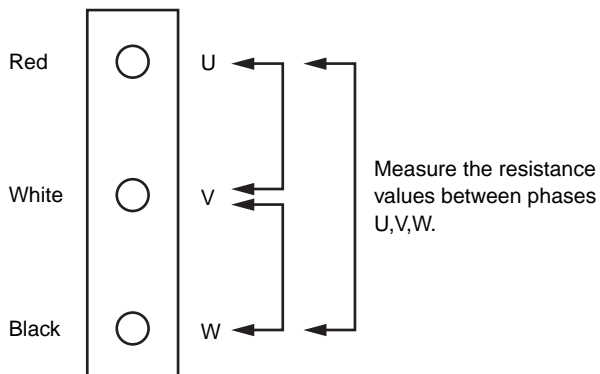
**Check No. 9**

(1) Turn off the power supply.

(2) Measure the resistance between Vcc and each phase of U,V,W, and GND and each phase at the motor side connectors (five-core wire) to check that the values are balanced within the range of  $\pm 20\%$ , while connector or relay connector is disconnected.

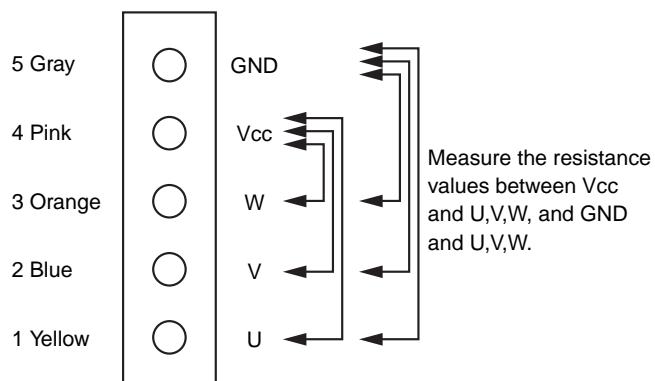

**Check No. 12**

**Check on pulse input of position signal of fan inverter PCB**

- (1) Disconnect the connector X2A while power supply OFF and operation OFF.
- (2) Is the voltage between pins No. 4 and 5 on X2A approx. 15 V after power supply is turned on?
- (3) Connect the connector X2A while power supply OFF and operation OFF.
- (4) Check below conditions when the fan motor is rotated one turn manually under the condition of operation OFF after power supply is turned ON.
  - Are the pulse (approx. 0 V and 5 V) generated 4 times between No. 1 and 5 on X2A?
  - Are the pulse (approx. 0 V and 5 V) generated 4 times between No. 2 and 5 on X2A?
  - Are the pulse (approx. 0 V and 5 V) generated 4 times between No. 3 and 5 on X2A?

The condition (2) dose not appear → Faulty PCB → Replacing the PCB  
 The conditions (4) do not appear → Faulty hall IC → Replacing fan motor of outdoor unit

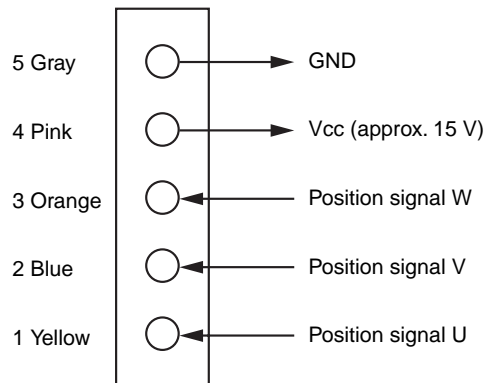

# Part 7

## Replacement procedure for INV compressor, VRV II (RXYQ5M to 48M)

1. Replacement procedure for INV compressor, VRV II (RXYQ5M-48M) .....	258
1.1 Replacement procedure .....	258

# 1. Replacement procedure for INV compressor, VRV II (RXYQ5M-48M)

## 1.1 Replacement procedure

- (1) Collect the refrigerant by using refrigerant recovery unit.  
(Since the setting on outdoor unit PCB is required for refrigerant recovery, refer to the warning plate "Precautions in service work" attached on the switch box cover.)
- (2) Remove the sound insulator mat covering the faulty compressor, and disconnect the power cable from terminal board of the compressor.
- (3) Disconnect the brazing sections of suction pipe and discharge pipe by using brazing torch after the refrigerant has been collected completely.
- (4) Pinch the oil pressure equalizing pipe of the faulty compressor at the lower part of the brazed joint as shown in figure 1, and cut it between the pinched section and brazed joint in order to prevent residual oil from discharging.
- (5) Remove three bolts at cushion rubber section to take out the faulty compressor outside the unit.
- (6) Check that no oil remains in the oil pressure equalizing pipe as shown in figure 2, then remove the cut pipe from the brazed joint with brazing torch.
- (7) Install the new compressor in the unit.  
(Be sure to insert the cushion rubbers before tightening the fixing bolts of compressor.)
- (8) Remove the rubber caps put on the suction and discharge pipe of the new compressor to release the sealing nitrogen gas.  
(Take note that oil may spout due to the pipe inside pressure if the plug put on the equalizing seat is removed before removing of rubber cap.)
- (9) Remove the plug put on the equalizing seat of the new compressor.
- (10) Install the outlet pipe on the equalizing seat of the new compressor.
- (11) Braze the equalizing seat outlet pipe to the oil pressure equalizing pipe with brazing torch.  
\* Since an O-ring is put in the equalizing seat, be sure to maintain the parts around O-ring in cool.
- (12) Braze the suction and discharge pipe with brazing torch to the compressor.
- (13) Conduct air tight test to check the piping system is free from leakage.
- (14) Connect power cable to the terminal board of compressor and cover the compressor with sound insulator mat.
- (15) Conduct vacuum drying.  
(Since the setting on outdoor unit PCB is required for vacuum drying, refer to the warning plate "Precautions in service work" attached on the switch box cover.)
- (16) Charge refrigerant after the completion of vacuum drying, and check the function of compressor with cooling or heating operation.

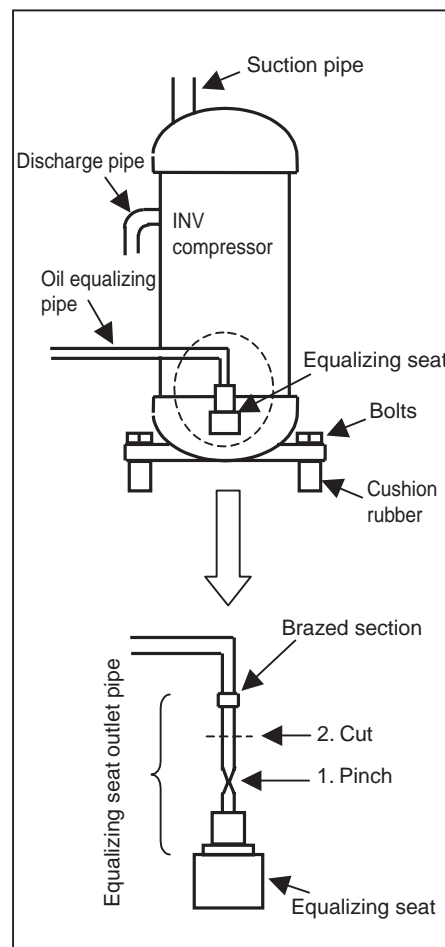

Fig. 1

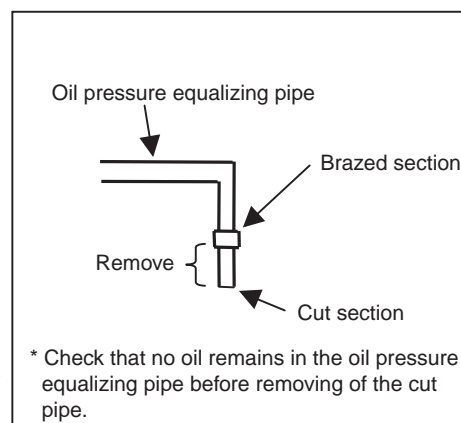

Fig. 2

# Part 8

## Appendix

1. Piping Diagrams.....	260
1.1 Outdoor Unit.....	260
1.2 Indoor Unit.....	263
2. Wiring Diagrams for Reference.....	269
2.1 Outdoor Unit.....	269
2.2 Field Wiring.....	272
2.3 Indoor Unit.....	275
3. List of Electrical and Functional Parts.....	293
3.1 Outdoor Unit.....	293
3.2 Indoor Side.....	295
4. Option List.....	301
4.1 Option List of Controllers.....	301
4.2 Option Lists (Outdoor Unit).....	303
5. Piping Installation Point.....	304
5.1 Piping Installation Point.....	304
5.2 The Example of A Wrong Pattern.....	305
6. Selection of Pipe Size, Joints and Header.....	306
6.1 RXYQ5MY1B, RXYQ8MY1B, RXYQ10MY1B, RXYQ12MY1B, RXYQ14MY1B, RXYQ16MY1B.....	306
6.2 RXYQ18MY1B, RXYQ20MY1B, RXYQ22MY1B, RXYQ24MY1B, RXYQ26MY1B, RXYQ28MY1B, RXYQ30MY1B, RXYQ32MY1B, RXYQ34MY1B, RXYQ36MY1B, RXYQ38MY1B, RXYQ40MY1B, RXYQ42MY1B, RXYQ44MY1B, RXYQ46MY1B, RXYQ48MY1B.....	308
7. Thermistor Resistance / Temperature Characteristics.....	311
8. Pressure Sensor.....	313
9. Method of Replacing The Inverter's Power Transistors and Diode Modules.....	314

# 1. Piping Diagrams

## 1.1 Outdoor Unit

RXYQ5MY1B

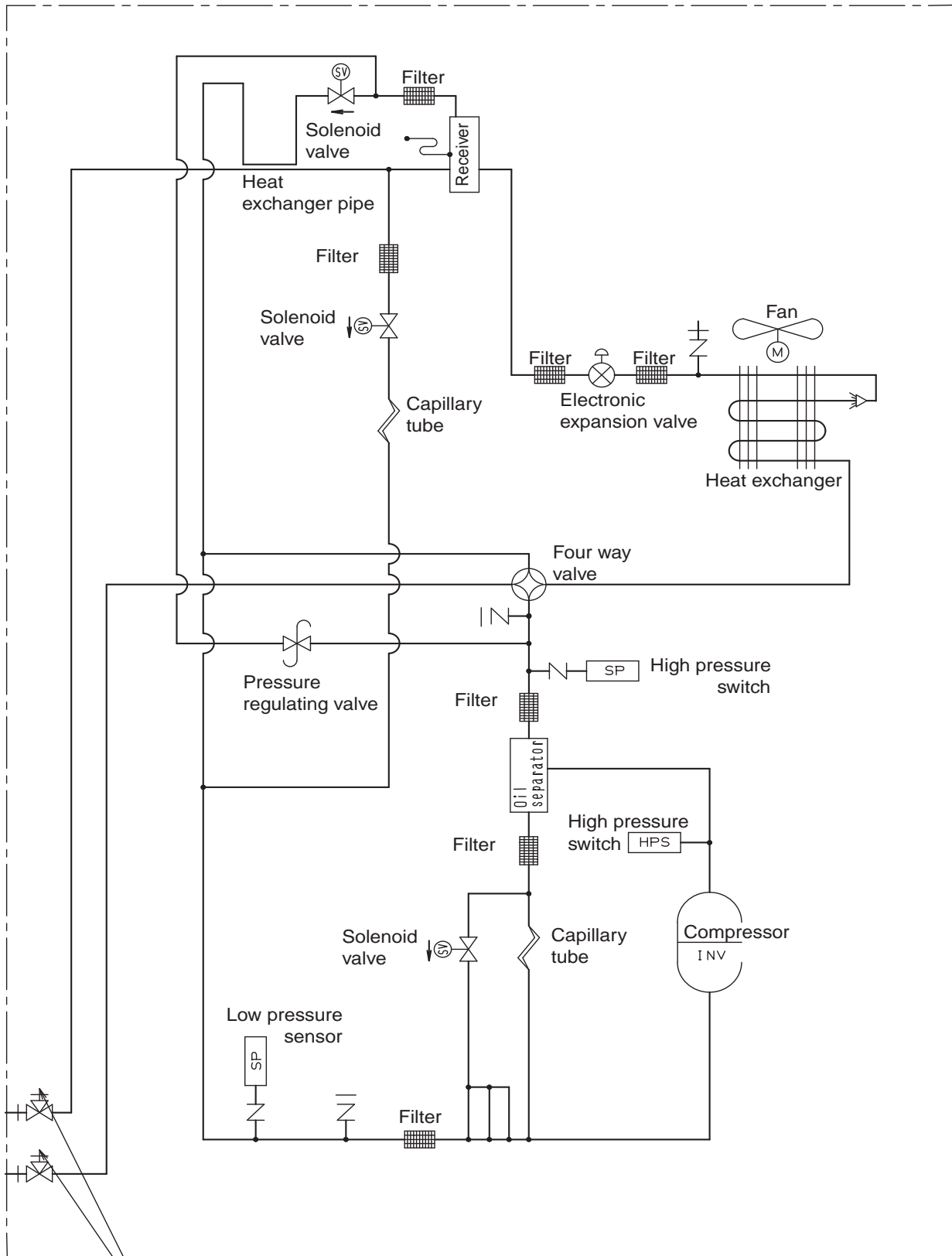

Stop valve (with service port on on-site piping side  $\varnothing$  7.9 mm flare connection)

4D040337C





RXYQ14MY1B  
RXYQ16MY1B

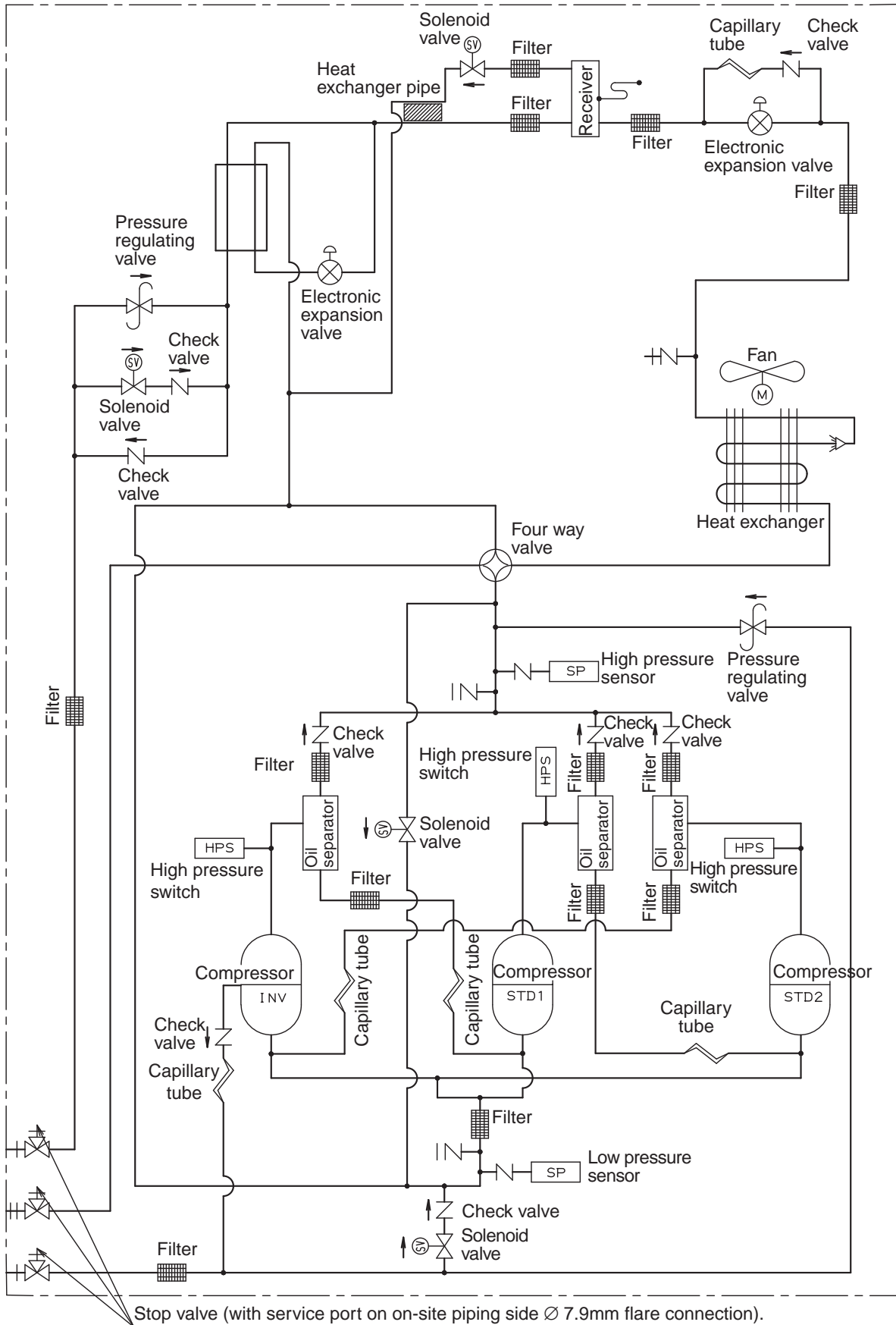

4D044809

## 1.2 Indoor Unit

FXCQ, FXZQ, FXFQ, FXKQ, FXSQ, FXMQ, FXHQ, FXAQ, FXLQ, FXNQ

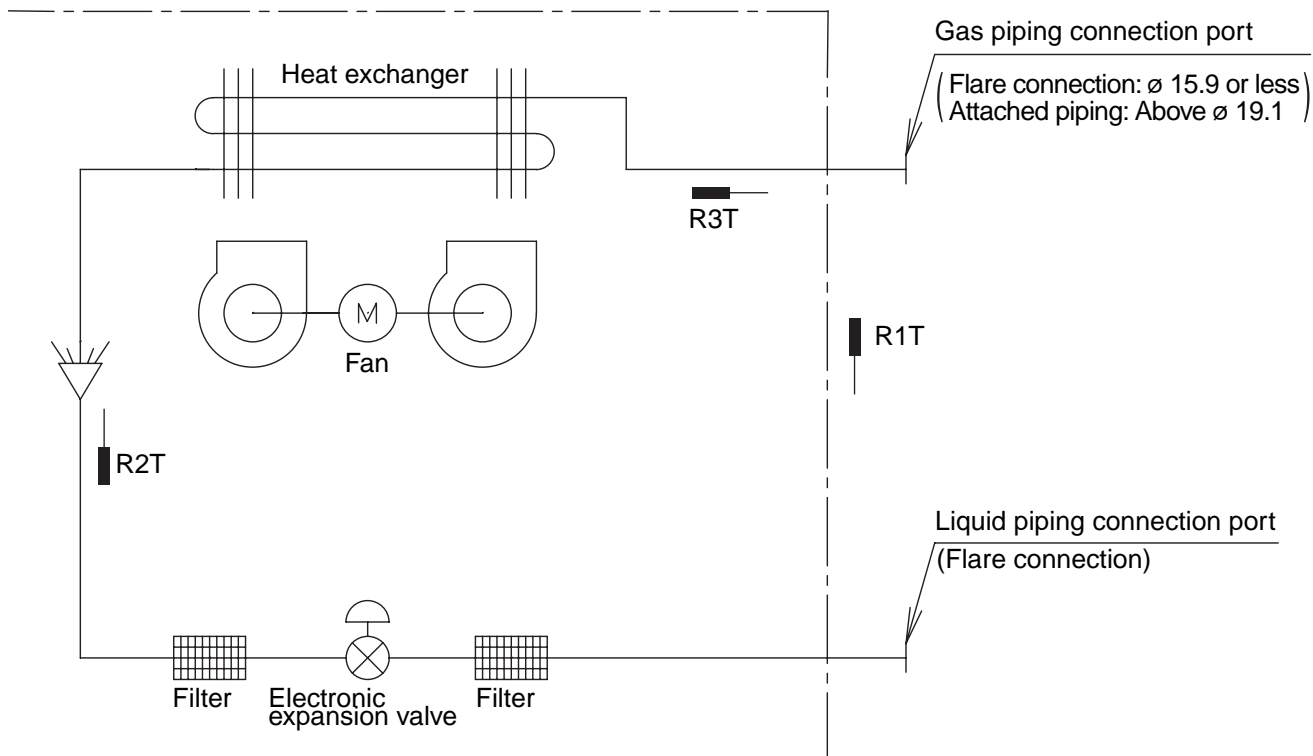

DU220-602D

R1T : Thermistor for suction air temperature

R2T : Thermistor for liquid line temperature

R3T : Thermistor for gas line temperature

(mm)

Capacity	GAS	Liquid
20 / 25 / 32 / 40 / 50M	$\varnothing$ 12.7	$\varnothing$ 6.4
63 / 80 / 100 / 125M	$\varnothing$ 15.9	$\varnothing$ 9.5
200M	$\varnothing$ 19.1	$\varnothing$ 9.5
250M	$\varnothing$ 22.2	$\varnothing$ 9.5

FXDQ

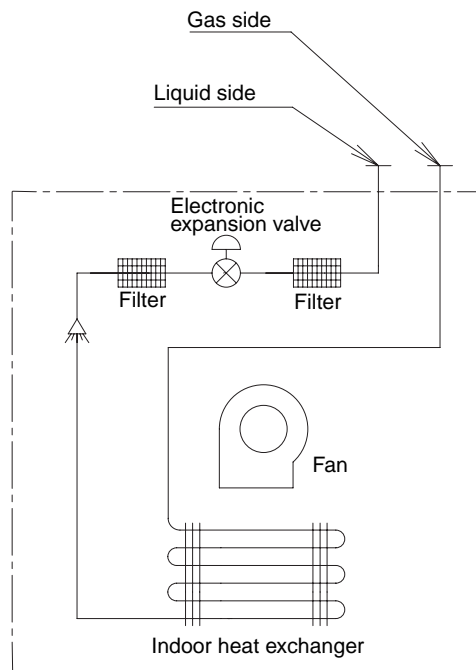

4D043864A

■ Refrigerant pipe connection port diameters

(mm)

Model	Gas	Liquid
FXDQ20N / 25N / 32N / 40N / 50NVE	φ12.7	φ6.4
FXDQ63NVE	φ15.9	φ9.5

## FXMQ125/200/250MFV1

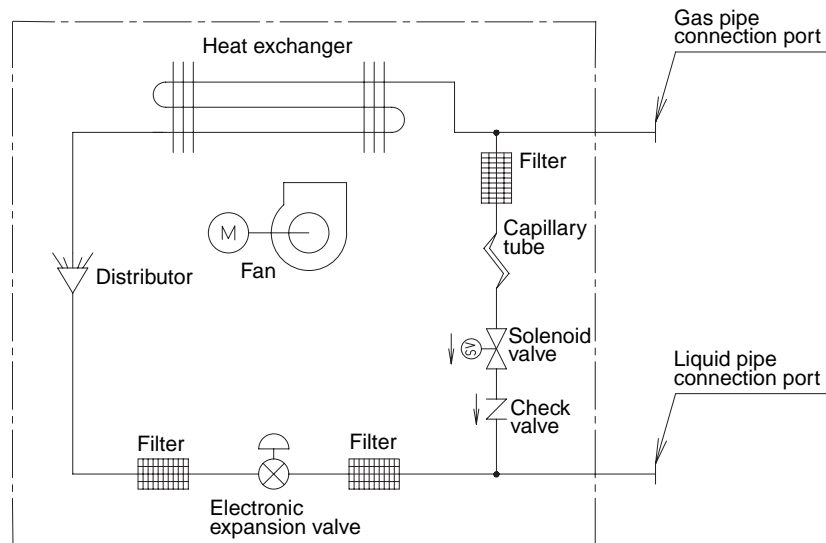

4D018650B

■ Refrigerant pipe connection port diameters

(mm)

Model	Gas	Liquid
FXMQ125MFV1	φ15.9	φ9.5
FXMQ200MFV1	φ19.1	φ9.5
FXMQ250MFV1	φ22.2	φ9.5

FXUQ + BEVQ

Indoor unit

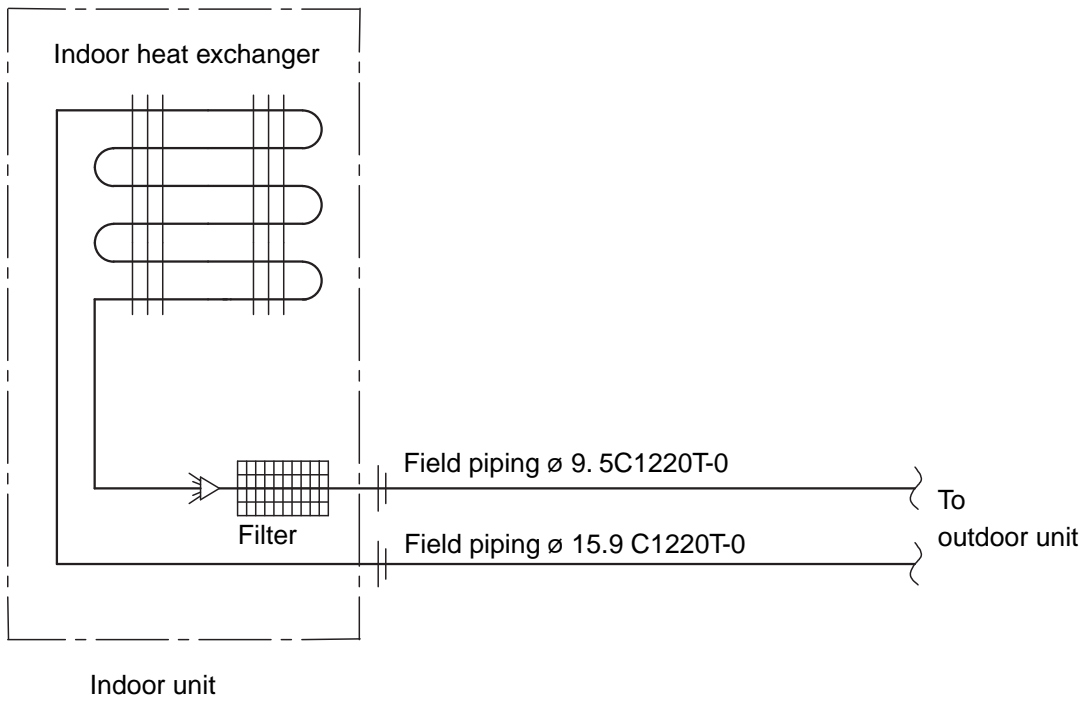

4D037995B

Connection Unit

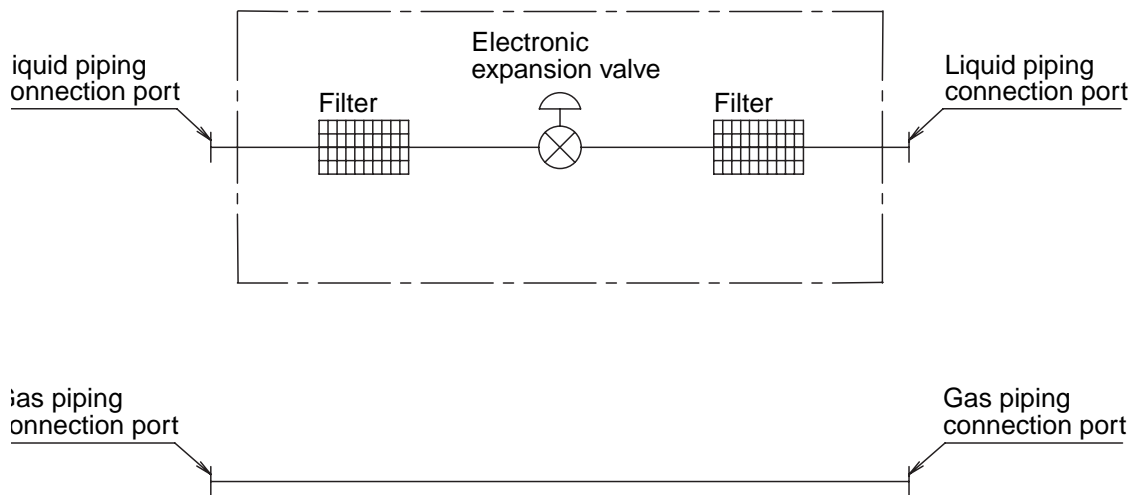

4D034127B

FXAQ + BEVQ

Indoor unit

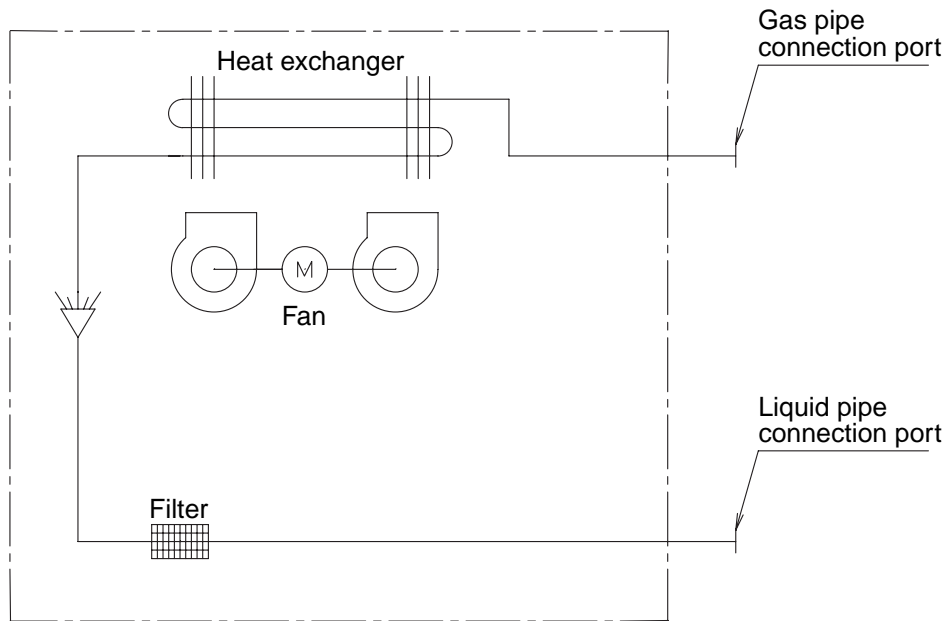

4D047084

Connection Unit

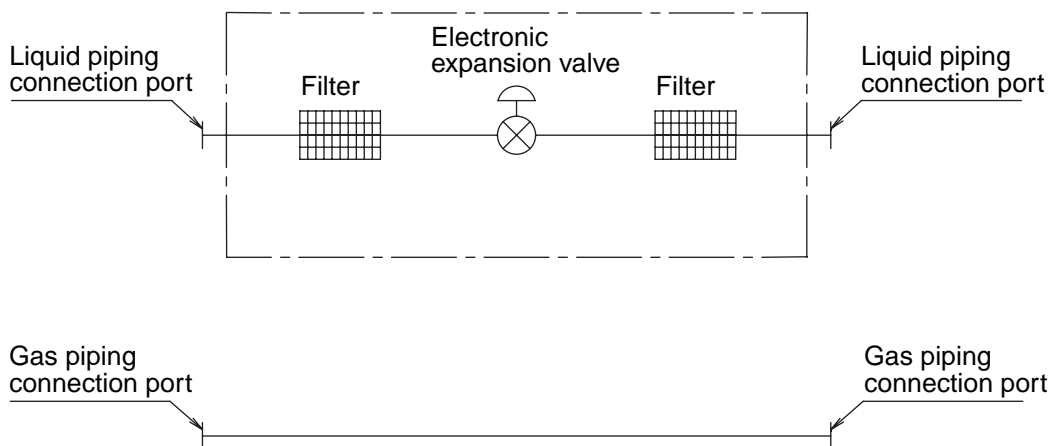

4D034127B

FXLQ + BEVQ

Indoor unit

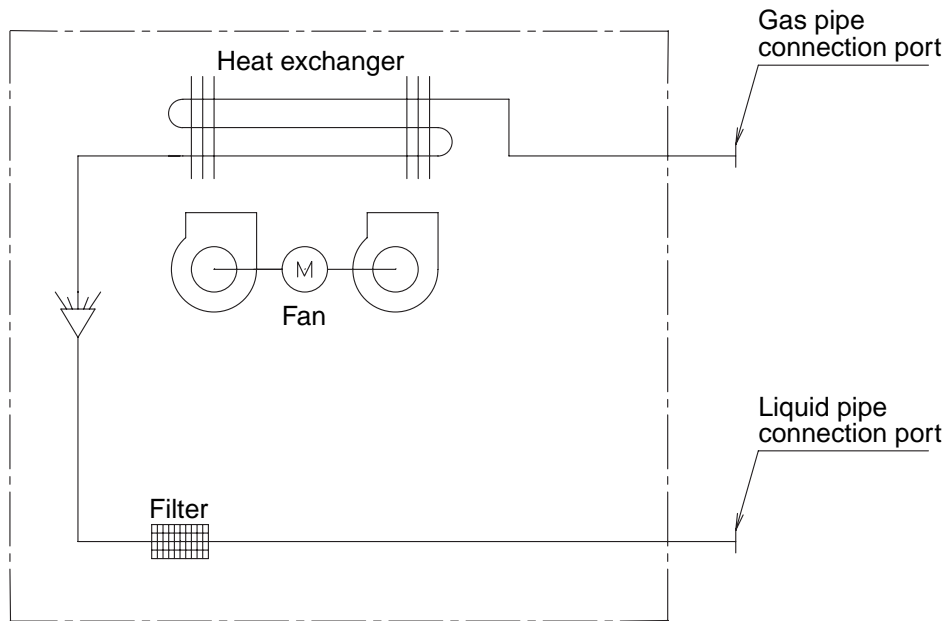

4D047084

Connection Unit

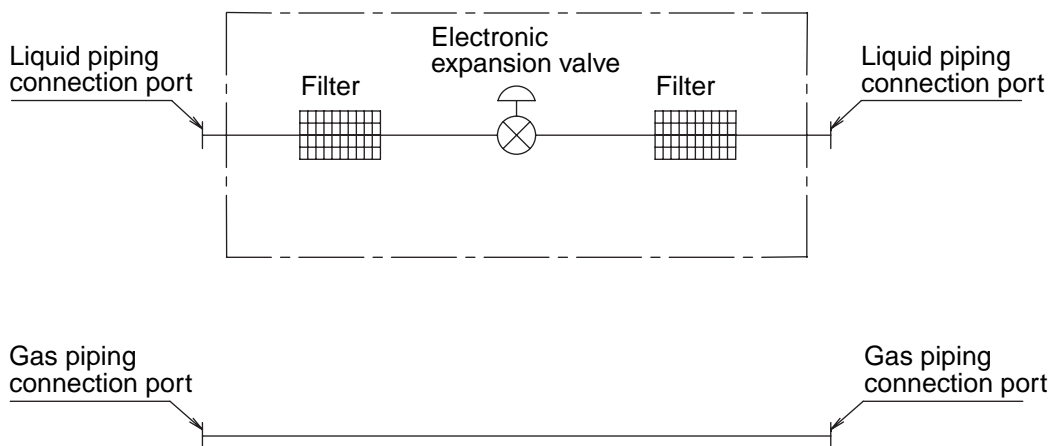

4D034127B

# 2. Wiring Diagrams for Reference

## 2.1 Outdoor Unit

RXYQ5MY1B

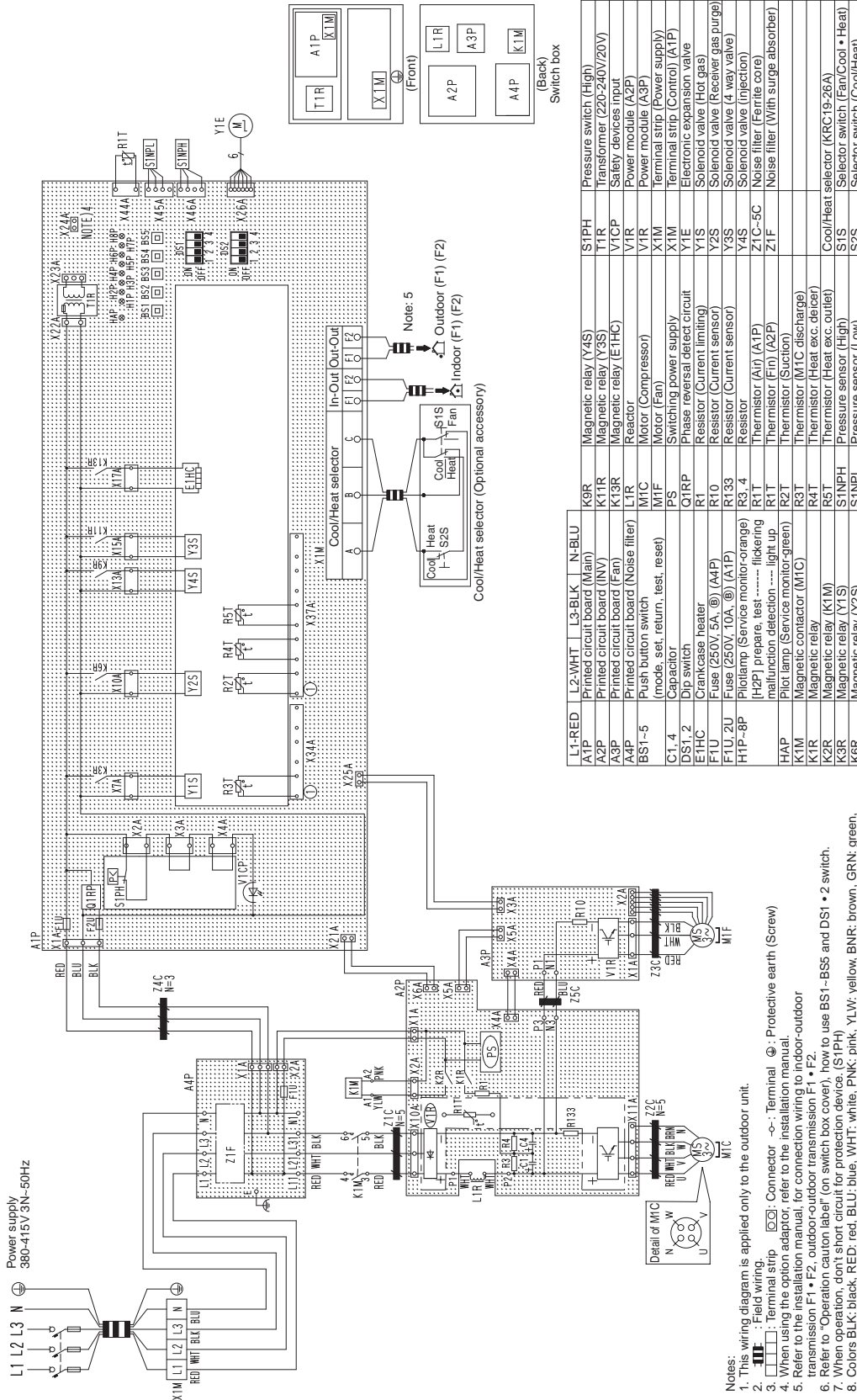

3D038590E





RXYQ14MY1B  
RXYQ16MY1B

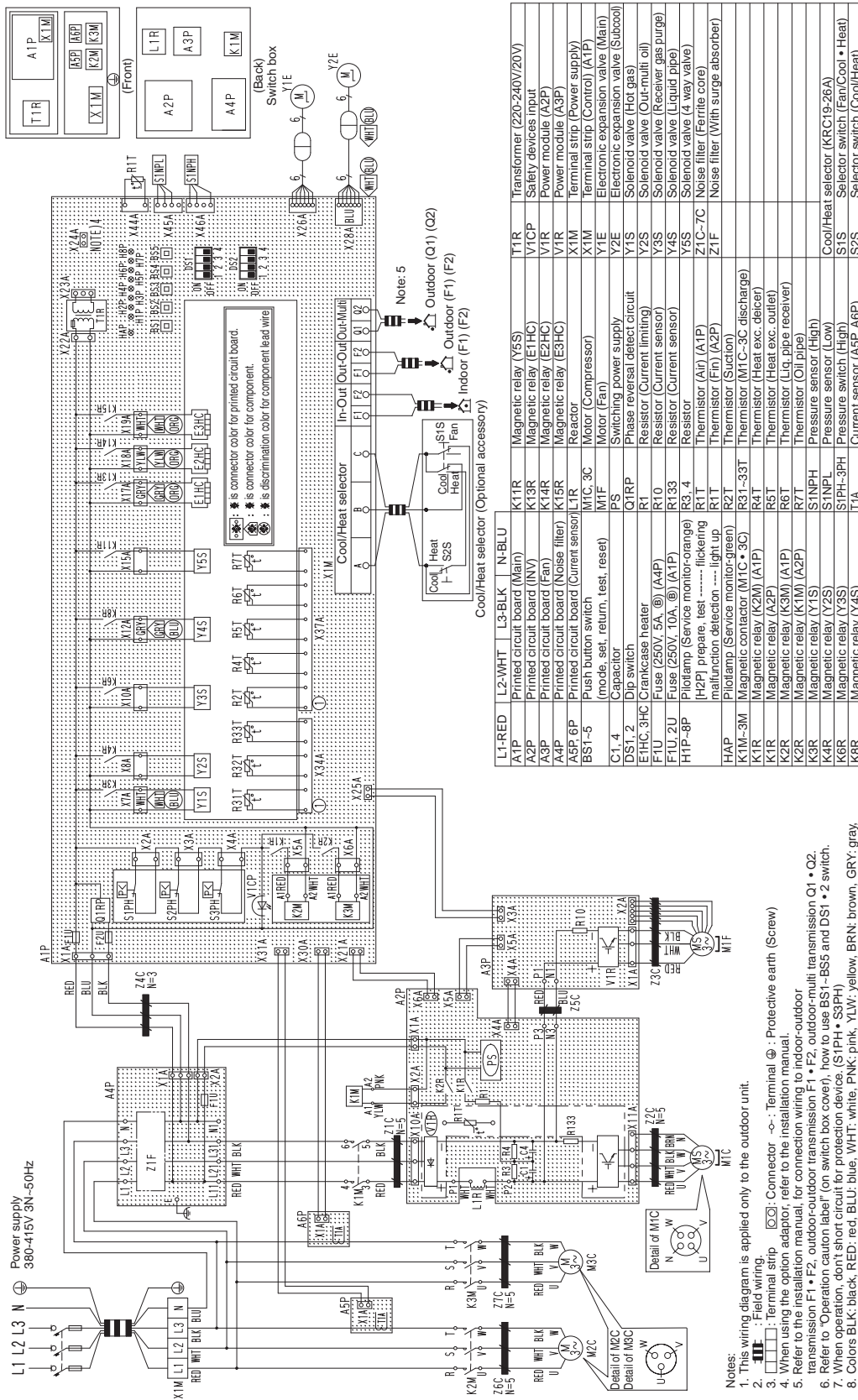

L1-RED	L2-WHT	L3-BLK	N-BLU	T1R	Transformer (220-240V/20V)
A1P	Printed circuit board (Main)	K11R	Magnetic relay (Y5S)	V1CP	Safety devices input
A2P	Printed circuit board (NV)	K13R	Magnetic relay (E1HC)	V1R	Power module (A2P)
A3P	Printed circuit board (Fan)	K14R	Magnetic relay (E2HC)	X1M	Terminal strip (Power supply)
A4P	Printed circuit board (Noise filter)	K15R	Magnetic relay (E3HC)	X1M	Terminal strip (Control) (A1P)
A5P-6P	Push button switch	MTC-3C	Motor (Compressor)	Y1E	Electronic expansion valve (Main)
C1.4	Capacitor	PS	Switching power supply	Y2E	Electronic expansion valve (Subcool)
DS1.2	Dip switch	Q1RP	Phase reverse detect circuit	Y1S	Solenoid valve (Hot gas)
E1HC, 3HC	Crankcase heater	R1	Resistor (Current limiting)	Y2S	Solenoid valve (Out-multi oil)
F1U, 2U	Fuse (250V, 5A, @) (A4P)	R10	Resistor (Current sensor)	Y3S	Solenoid valve (Receiver, gas purge)
F1U, 2U	Fuse (250V, 10A, @) (A1P)	R133	Resistor (Current sensor)	Y4S	Solenoid valve (Liquid pipe)
H1P-8P	Pilotlamp (Service monitor-orange)	R3.4	Resistor	Y6S	Solenoid valve (4 way valve)
H2P	Pilotlamp (Service monitor-orange)	R1T	Thermistor (A1P)	Z1C-7C	Noise filter (Ferrite core)
H2P	Pilotlamp (Service monitor-orange)	R1T	Thermistor (Fin) (A2P)	Z1F	Noise filter (With surge absorber)
HAP	Pilotlamp (Service monitor-green)	R2T	Thermistor (Suction)		
K1M-3M	Magnetic contactor (M1C * 3C)	R31-33T	Thermistor (M1C-3C discharge)		
K1R	Magnetic relay (K3M) (A1P)	R4T	Thermistor (Heat exc. device)		
K2R	Magnetic relay (A2P)	R5T	Thermistor (Heat exc. outlet)		
K2R	Magnetic relay (K3M) (A1P)	R6T	Thermistor (Heat exc. outlet)		
K2R	Magnetic relay (K1M) (A2P)	R7T	Thermistor (Liq. pipe receiver)		
K3R	Magnetic relay (Y1S)	S1NPH	Pressure sensor (High)		
K4R	Magnetic relay (Y2S)	S1NPL	Pressure sensor (Low)		
K6R	Magnetic relay (Y3S)	S1PH-3PH	Pressure switch (High)		
K8R	Magnetic relay (Y4S)	T1A	Current sensor (A5P, A6P)		

- Notes:
- This wiring diagram is applied only to the outdoor unit.
  - Field wiring.
  - Terminal strip.
  - When using the option adaptor, refer to the installation manual.
  - Refer to the instruction manual, for connection wiring to indoor-outdoor transmission F1 + F2, outdoor floor transmission F1 + F2, outdoor multi transmission O1 + O2.
  - Refer to "Operation caution label" (on switch box cover), to use BS1-BS5 and DS1 + 2 switch.
  - When operation, do not short circuit for protection devices. (S1PH + S3PH).
  - Colors: BLK: black; RED: red; BLU: blue; WHT: white; PNK: pink; YLV: yellow; BRN: brown; GRY: gray; GRN: green; ORG: orange.

## 2.2 Field Wiring

### RXYQ5~16MY1B

- 6) Unit shall be grounded in compliance with the applicable local and national codes.
- 7) Wiring shown are general points-of-connection guides only and are not intended for or to include all details for a specific installation.
- 8) Be sure to install the switch and the fuse to the power line of each equipment.
- 9) Install the main switch that can interrupt all the power sources in an integrated manner because this system consists of the equipment utilizing the multiple power sources.

- Notes
- 1) All wiring, components and materials to be procured on the site must comply with the applicable local and national codes.
  - 2) Use copper conductors only.
  - 3) As for details, see wiring diagram.
  - 4) Install circuit breaker for safety.
  - 5) All field wiring and components must be provided by licensed electrician.

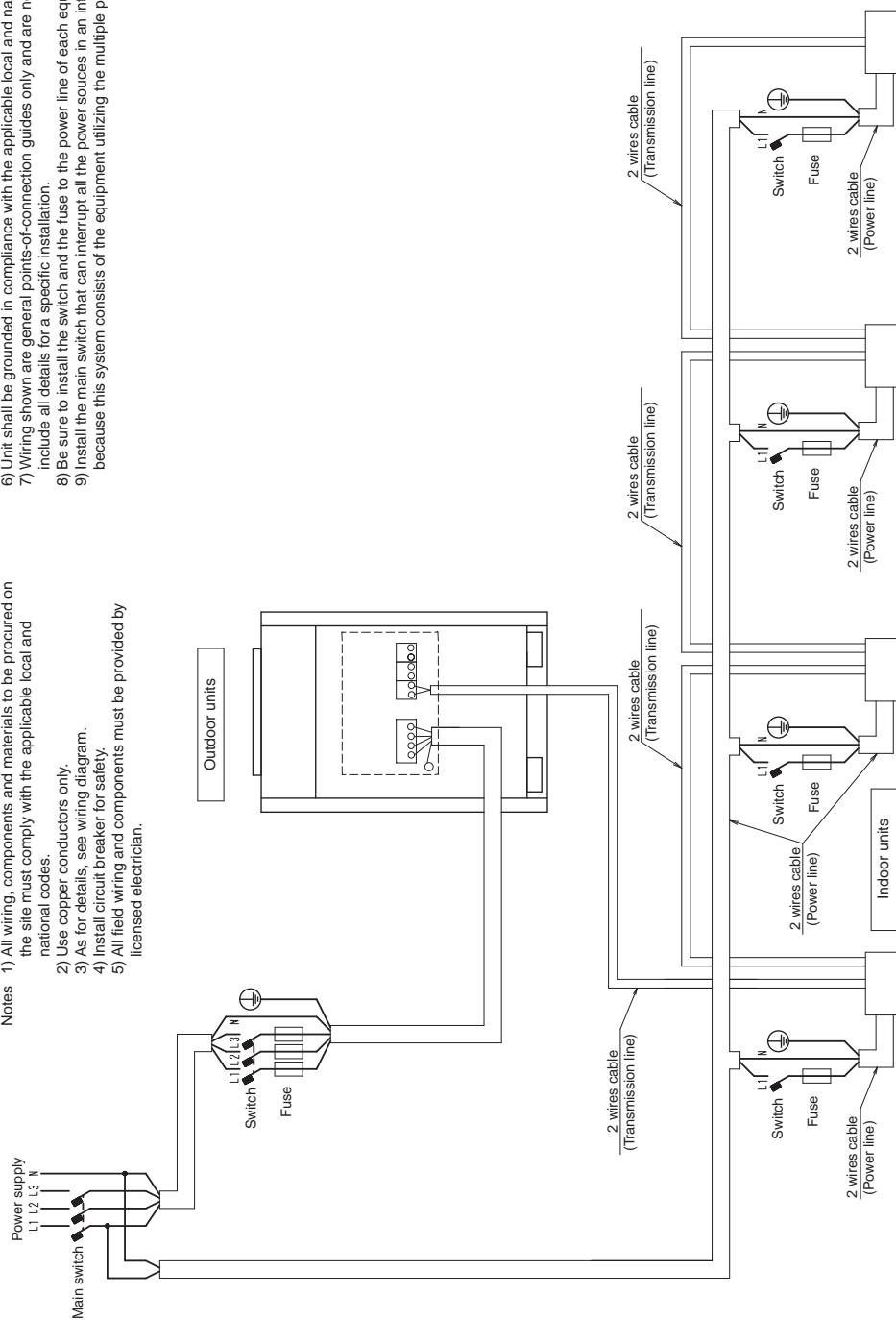

3D040746C

RXYQ18, 20, 22, 24, 26, 28, 30, 32MY1B

- Notes
- 1) All wiring, components and materials to be procured on the site must comply with the applicable local and national codes.
  - 2) Use copper conductors only.
  - 3) As for details, see wiring diagram.
  - 4) Install circuit breaker for safety.
  - 5) All field wiring and components must be provided by licensed electrician.
  - 6) Unit shall be grounded in compliance with the applicable local and national codes.
  - 7) Wiring shown are general points-of-connection guides only and are not intended for or to include all details for a specific installation.
  - 8) Be sure to install the switch and the fuse to the power line of each equipment.
  - 9) Install the main switch that can interrupt all the power sources in an integrated manner because this system consists of the equipment utilizing the multiple power sources.
  - 10) The capacity of UNIT1 must be larger than UNIT2 when the power source is connected in series between the units.

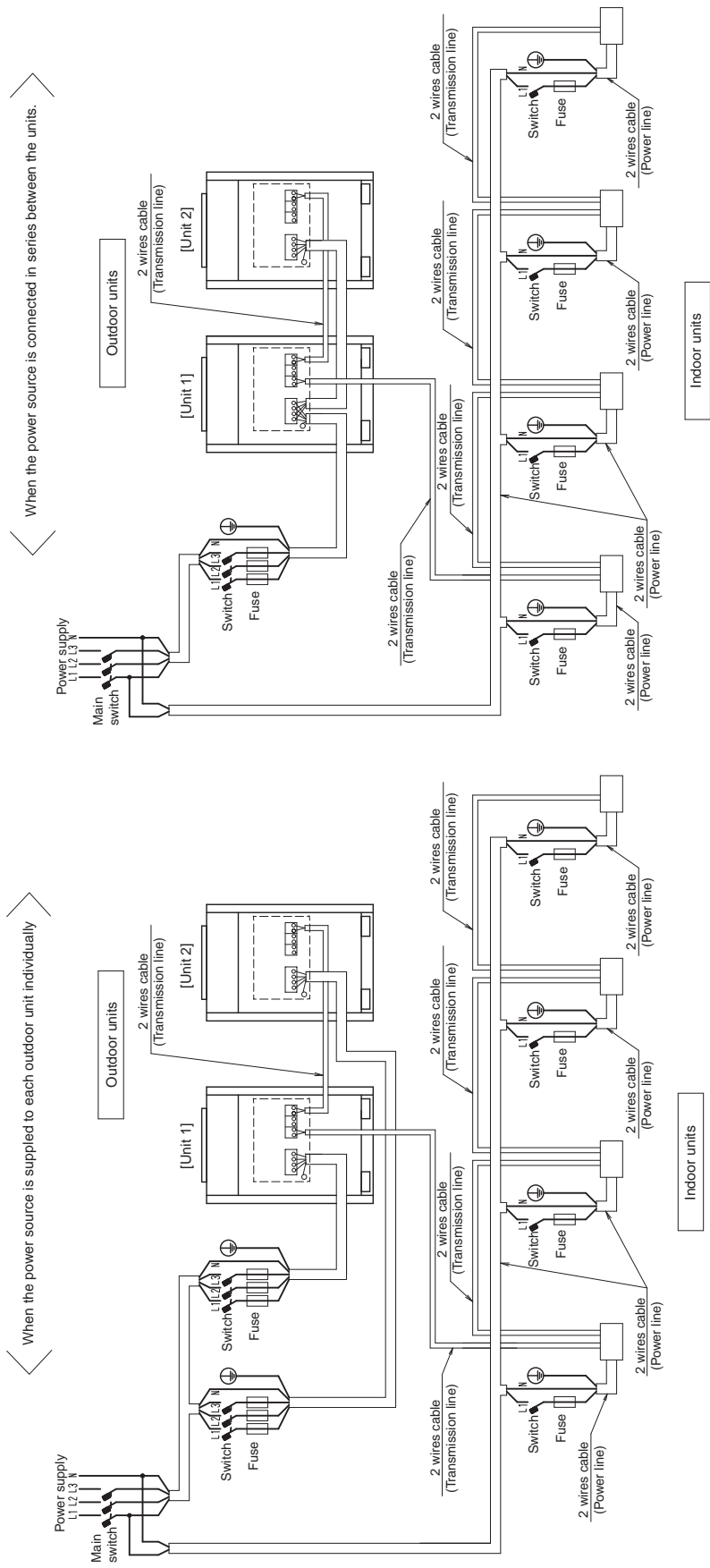

3D040747B

RXYQ34, 36, 38, 40, 42, 44, 46, 48MY1B

- Notes
- 1) All wiring, components and materials to be procured on the site must comply with the applicable local and national codes.
  - 2) Use copper conductors only.
  - 3) As for details, see wiring diagram.
  - 4) Install circuit breaker for safety.
  - 5) All field wiring and components must be provided by licensed electrician.
  - 6) Unit shall be grounded in compliance with the applicable local and national codes.
  - 7) Wiring shown are general points-of-connection guides only and are not intended for or to include all details for a specific installation.
  - 8) Be sure to install the switch and the fuse to the power line of each equipment.
  - 9) Install the main switch that can interrupt all the power sources in an integrated manner because this system consists of the equipment utilizing the multiple power sources.
  - 10) Unit 1 must be RXYQ16MY1B when the power source is connected in series between the units. (In case of RXYQ34MY1B, RXYQ14MY1B.)

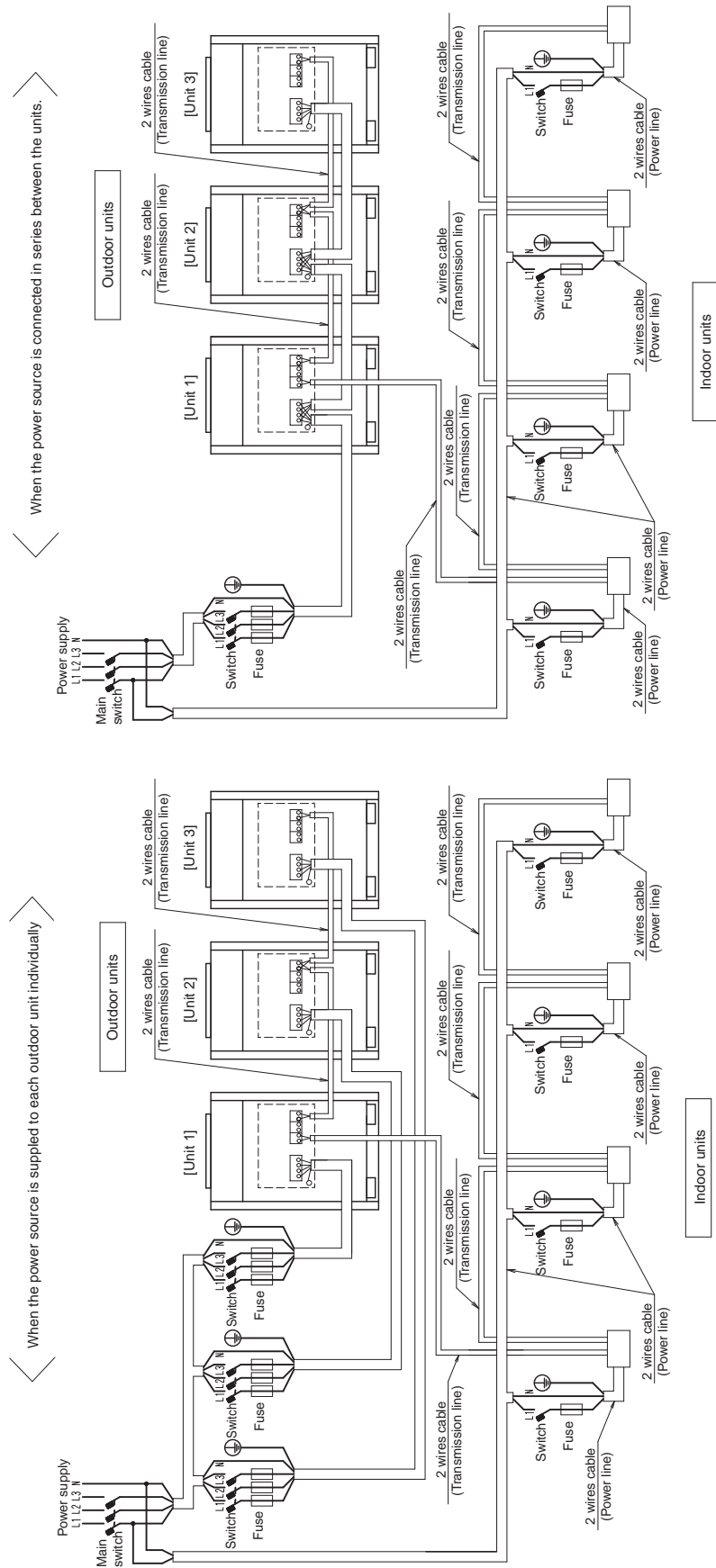

3D040748B

# 2.3 Indoor Unit

FXCQ20M / 25M / 32M / 63MVE

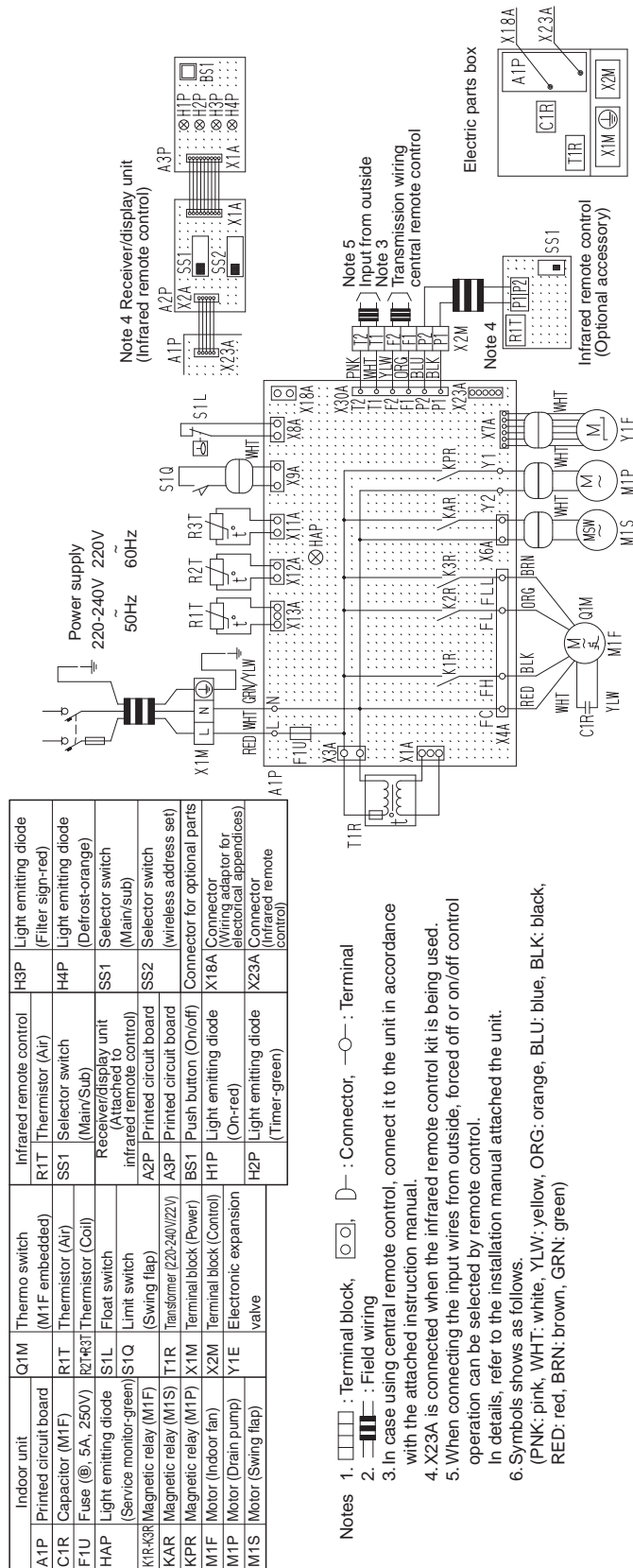

9D039556A

FXCQ40M / 50M / 80M/ 125MVE

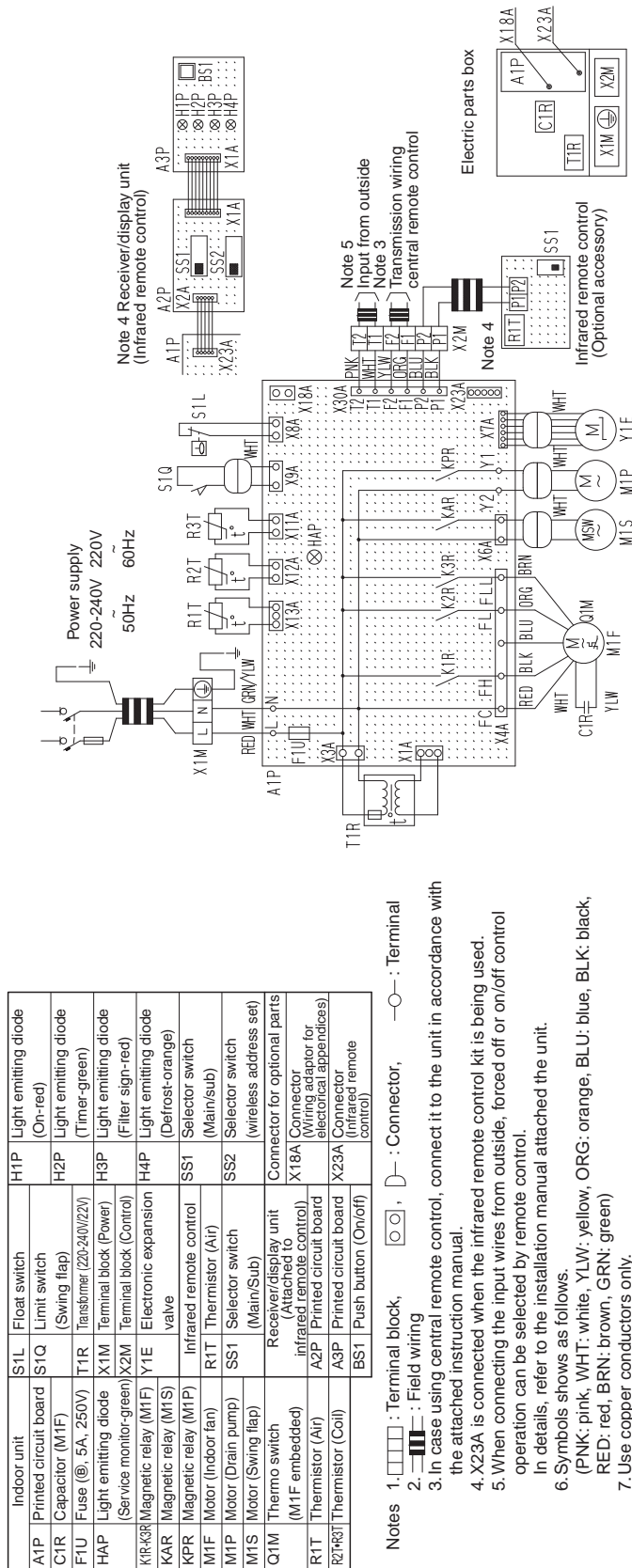

3D099557A

Indoor unit	S1L	Float switch	H1P	Light emitting diode (On-red)
A1P	S1Q	Limit switch	H2P	Light emitting diode (Timer-green)
C1R	T1R	(Swing flap)	H3P	Light emitting diode (Filter sign-red)
F1U	X1M	Transformer (220-240V/22V)	H4P	Light emitting diode (Defrost-orange)
HAP	X2M	Terminal block (Power)	SS1	Selector switch (Main/sub)
K1R-K3R	Y1E	(Service monitor-green)	SS2	Selector switch (wireless address set)
KAR	M1S	Magnetic relay (M1F)	Q1M	Thermo switch
KPR	M1P	Magnetic relay (M1S)	R1T	Thermistor (Air)
M1F	M1S	Magnetic relay (M1P)	SS1	Selector switch (Main/Sub)
M1P	M1F	Magnetic relay (M1S)	A2P	Receiver/display unit (Attached to infrared remote control)
M1S	M1P	Magnetic relay (M1F)	A3P	Printed circuit board (Wiring adaptor for electrical appendices)
Q1M	M1S	Thermo switch	X23A	Connector (Infrared remote control)
R1T	M1P	Thermistor (Air)	BS1	Push button (On/off)
R2T-R3T	M1S	Thermistor (Coil)		

- Notes
1. : Terminal block, : Connector, : Field wiring
  2. : Terminal block, : Connector, : Field wiring
  3. In case using central remote control, connect it to the unit in accordance with the attached instruction manual.
  4. X23A is connected when the infrared remote control kit is being used.
  5. When connecting the input wires from outside, forced off or on/off control operation can be selected by remote control.
  6. Symbols shows as follows.  
 (PNK: pink, WHT: white, YLW: yellow, ORG: orange, BLU: blue, BLK: black, RED: red, BRN: brown, GRN: green)
  7. Use copper conductors only.

FXZQ20M / 25M / 32M / 40M / 50MVE

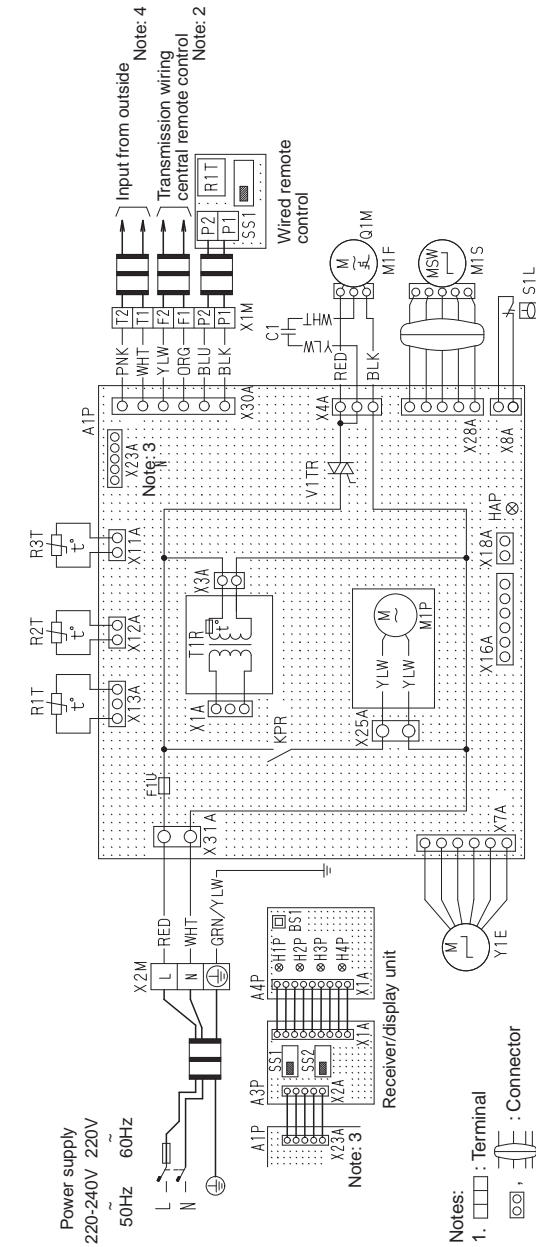

3D038359

A1P	Printed circuit board	BS1	Push button (On/off)
C1	Capacitor (M1F)	H1P	Light emitting diode (On-red)
F1U	Fuse (ø. 5A, 250V)	H2P	Light emitting diode (Timer-green)
HAP	Light emitting diode (Service monitor-green)	H3P	Light emitting diode (Filter sign-red)
KPR	Magnetic relay (M1P)	H4P	Light emitting diode (Defrost-orange)
M1F	Motor (Indoor fan)	SS1	Selector switch (Main/sub)
M1S	Motor (Drain pump)	SS2	Selector switch (wireless address set)
M1S	Motor (Swing flap)	S1L	Float switch
Q1M	Thermal protector (M1F-embedded)	T1R	Transformer (220-240V/22V)
R1T	Thermistor (Air)	V1TR	Triac
R2T	Thermistor (Coil-liquid)	X1M	Terminal block
R3T	Thermistor (Coil-gas)	X2M	Terminal block
S1L	Float switch	Y1E	Electronic expansion valve
T1R	Transformer (220-240V/22V)	R1T	Thermistor (Air)
V1TR	Triac	SS1	Selector switch (Main/Sub)
X1M	Terminal block	A3P	Infrared remote control (Receiver/display unit)
X2M	Terminal block	A4P	Printed circuit board
Y1E	Electronic expansion valve		

Notes:

1. □ : Terminal  
 : Connector  
 : Field wiring
2. In case using central remote control, connect it to the unit in accordance with the attached installation manual.
3. X23A is connected when the infrared remote control kit is being used.
4. When connecting the input wires from outside, forced off or on/off control operation can be selected by remote control. In details, refer to the installation manual attached the unit.
5. Remote control model varies according to de combination system, confirm engineering materials and catalogs, etc. before connecting.
6. Symbols shows as follows: RED: red, BLK: black, WHT: white, YLW: yellow, PNK: pink, ORG: orange, GRN: green, BLU: blue.

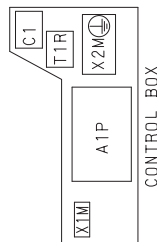



FXFQ25M / 32M / 40M / 50M / 63M / 80M / 100M / 125MVE

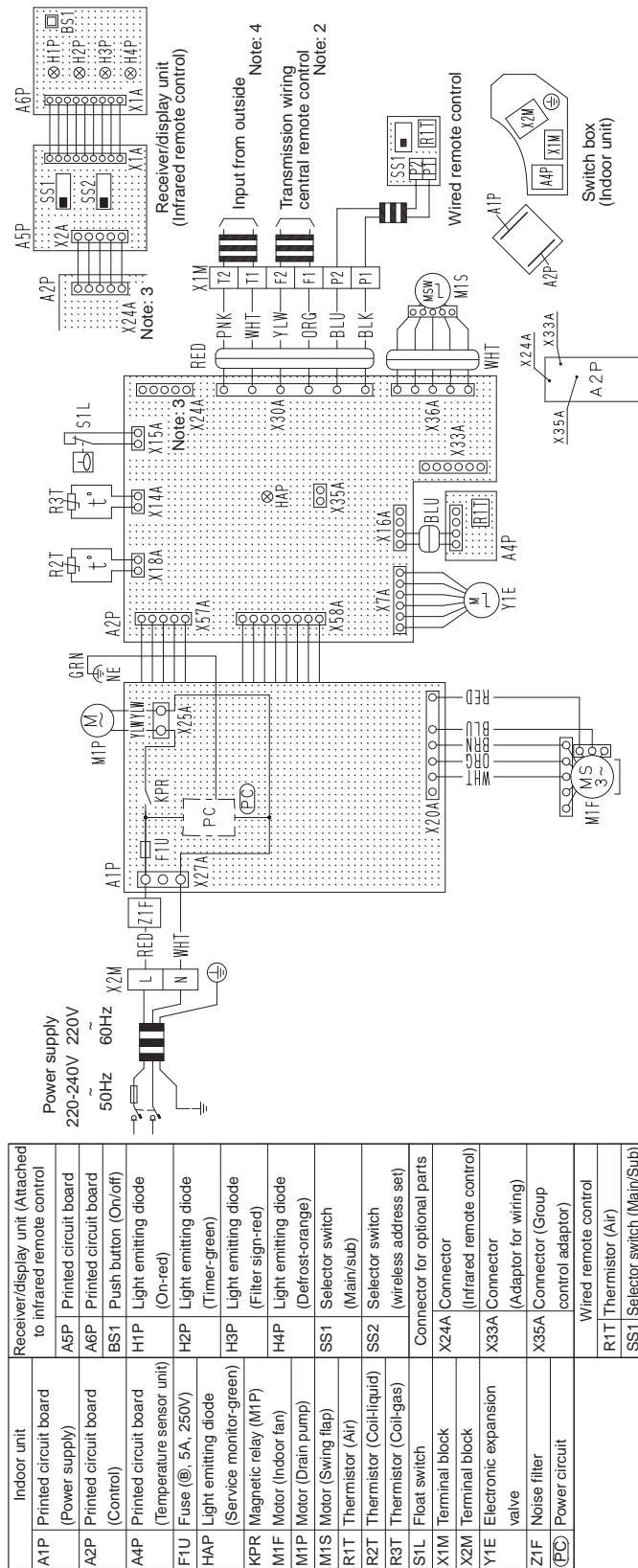

Notes:

1. : Terminal block : Field wiring
2. In case using central remote control, connect it to the unit in accordance with the attached installation manual.
3. X24A is connected when the infrared remote control kit is being used.
4. When connecting the input wires from outside, forced off or on/off control operation can be selected by remote control.

In details, refer to the installation manual attached the unit.

5. Remote control model varies according to de combination system, confirm engineering materials and catalogs, etc. before connecting.

6. Confirm the method of setting the selector switch (SS1, SS2) of wired remote control and infrared remote control by installation manual and engineering data, etc.

7. Symbols shows as follows: RED: red, BLK: black, WHT: white, YLW: yellow, GRN: green, ORG: orange, BRN: brown, PNK: pink, GRY: gray, BLU: blue.

3D039600A



FXDQ20N / 25N / 32N / 40N / 50N / 63NVE

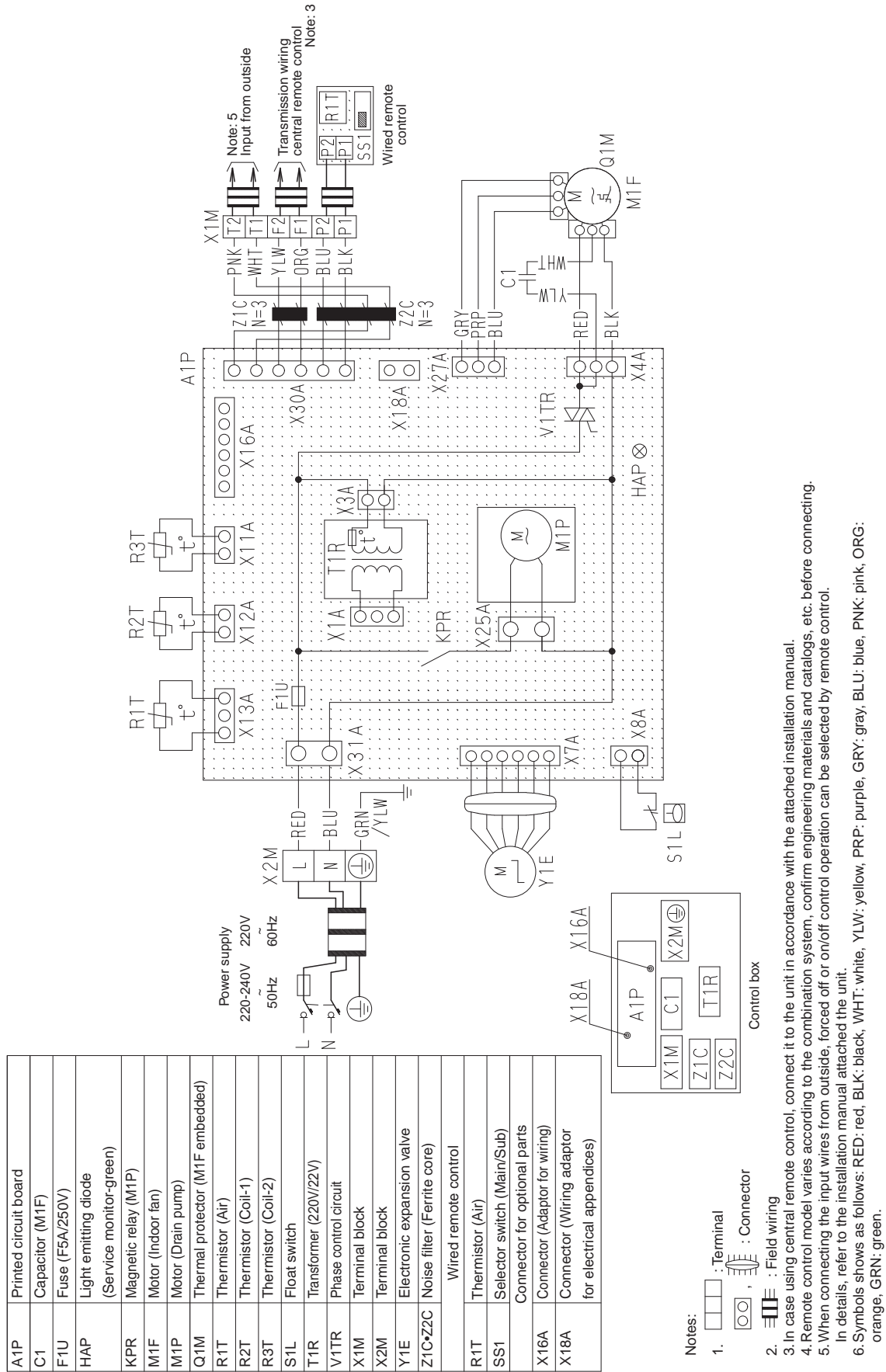

3D045500A



FXMQ40M / 50M / 63M / 80M / 100M / 125MVE

3D099620A

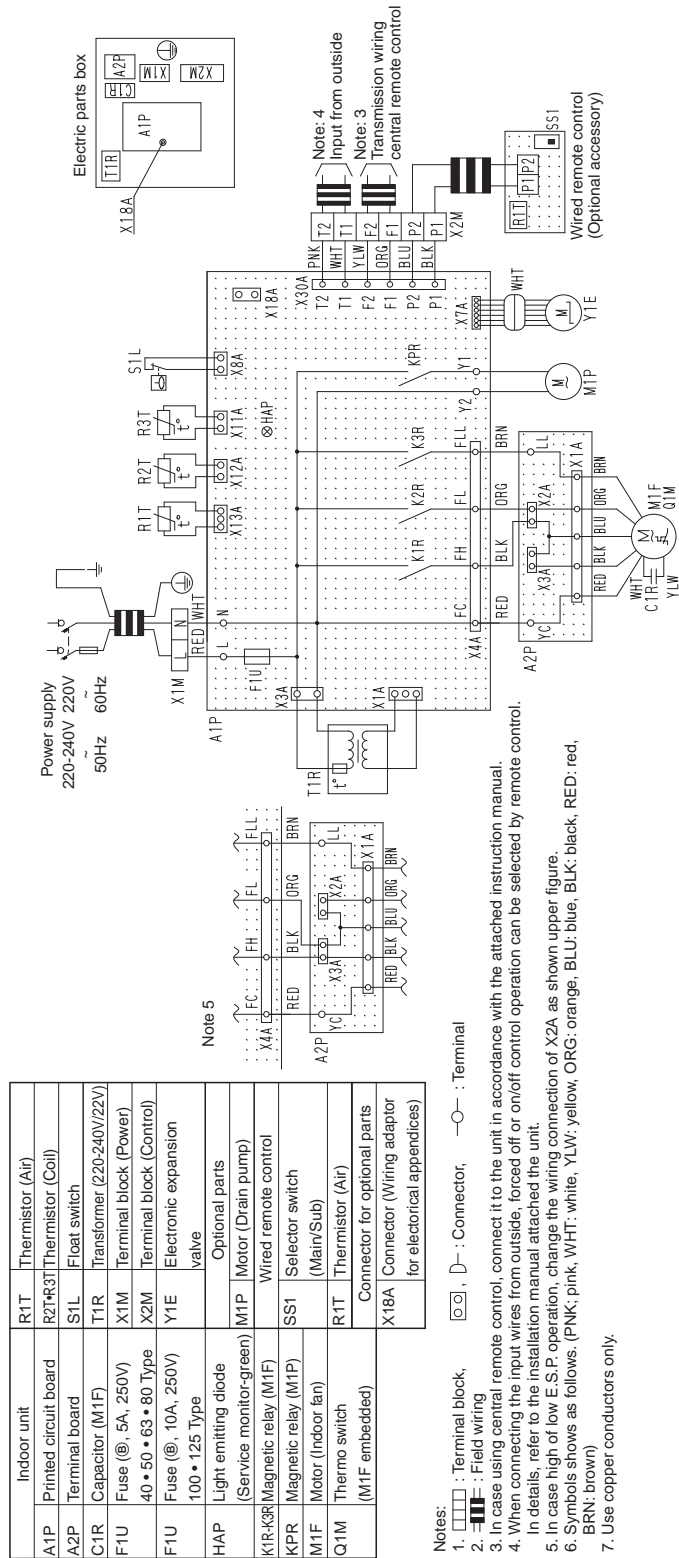

A1P	Indoor unit	R1T	Thermistor (Air)
A2P	Printed circuit board	R2T-R3T	Thermistor (Coil)
C1R	Terminal board	S1L	Float switch
F1U	Capacitor (M1F)	T1R	Transformer (220-240V/22V)
F1V	Fuse (@. 5A, 250V)	X1M	Terminal block (Power)
F1W	Fuse (@. 63 • 80 Type)	X2M	Terminal block (Control)
HAP	Fuse (@. 10A, 250V)	Y1E	Electronic expansion valve
K1R-K3R	100 • 125 Type		
M1F	Light emitting diode (Service monitor-green)	M1P	Motor (Drain pump)
Q1M	Magnetic relay (M1F)	SS1	Wired remote control
	Motor (Indoor fan)	R1T	Thermistor (Air)
	Thermo switch (M1F embedded)	X18A	Connector for optional parts for electrical appendices)

FXMQ200M / 250MVE

3D039621A

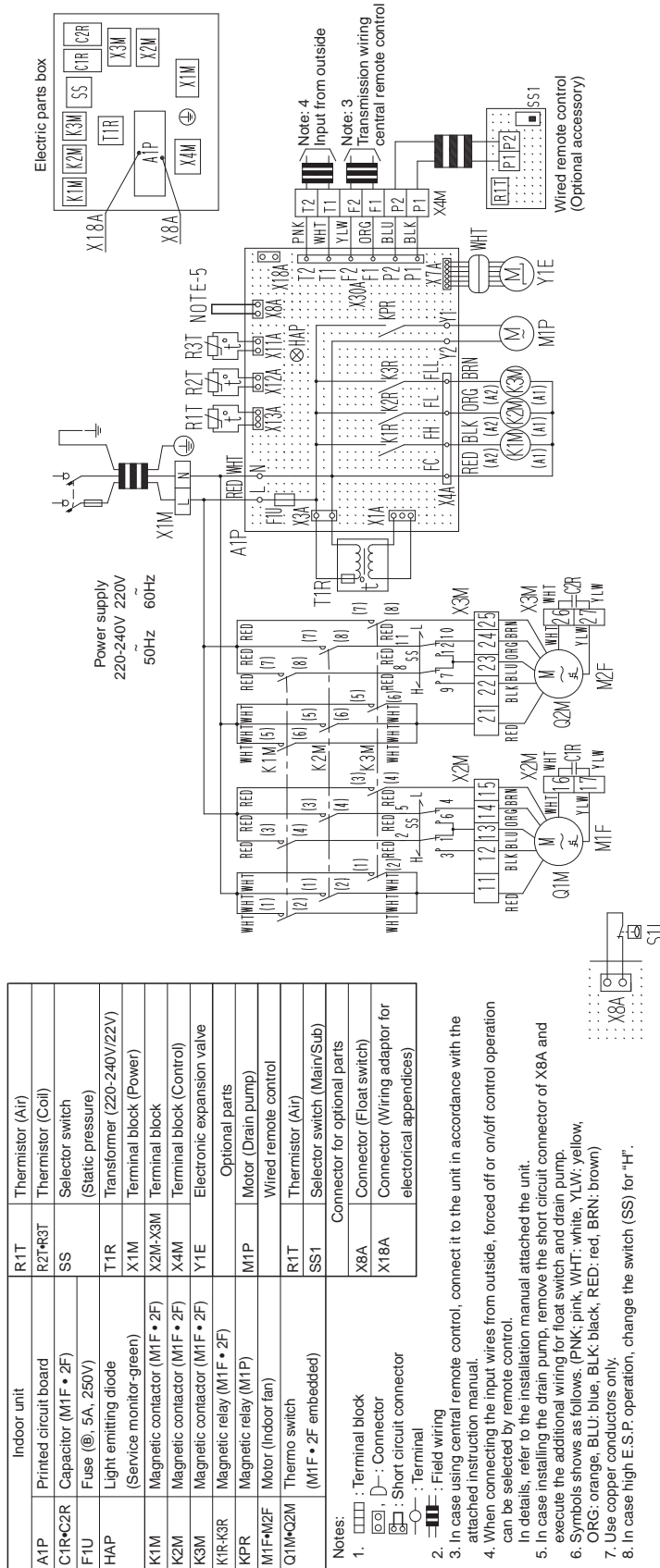

FXHQ32M / 63M / 100MVE

3D039801C

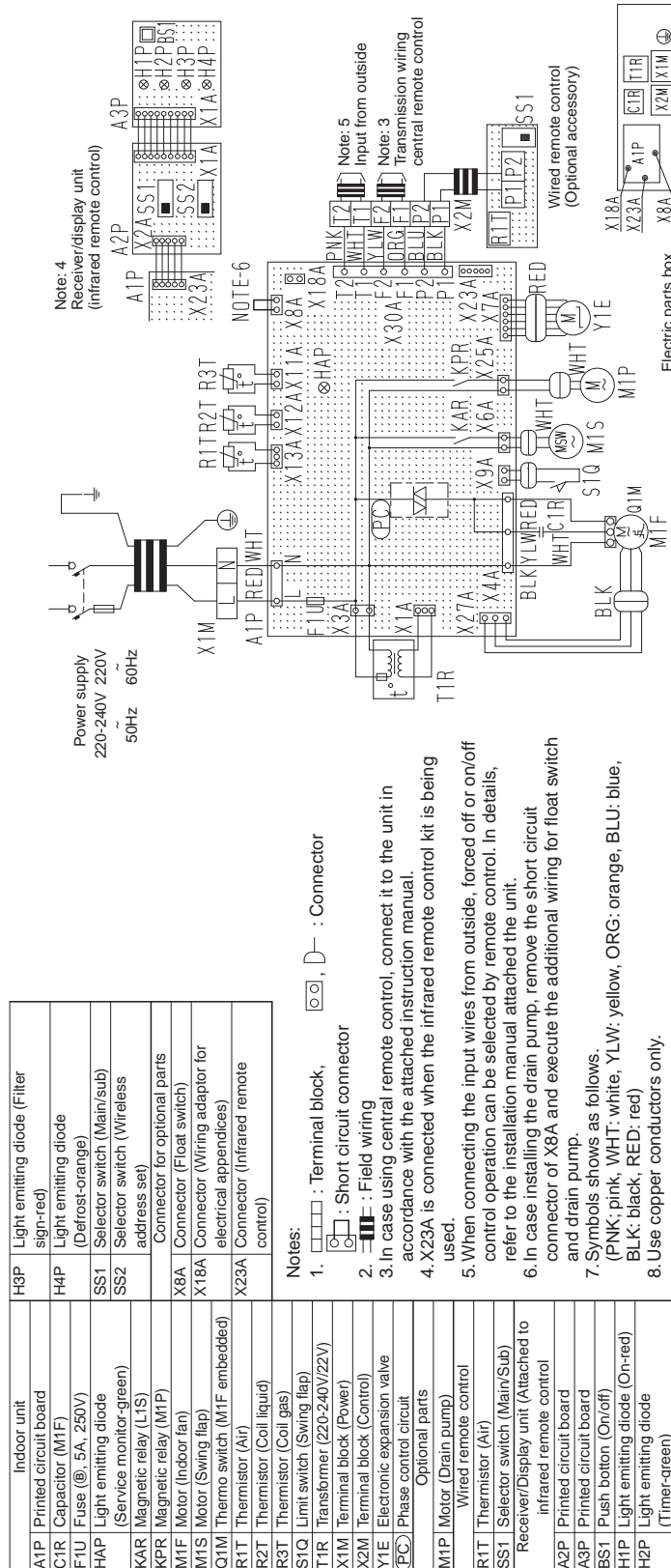

- Notes:
1. : Terminal block, : Short circuit connector
  2. : Field wiring
  3. In case using central remote control, connect it to the unit in accordance with the attached instruction manual.
  4. X23A is connected when the infrared remote control kit is being used.
  5. When connecting the input wires from outside, forced off or on/off control operation can be selected by remote control. In details, refer to the installation manual attached to the unit.
  6. In case installing the drain pump, remove the short circuit connector of X8A and execute the additional wiring for float switch and drain pump.
  7. Symbols shows as follows.  
(PNK: pink, WHT: white, YLW: yellow, ORG: orange, BLU: blue, BLK: black, RED: red)
  8. Use copper conductors only.

A1P	Indoor unit	H8P	Light emitting diode (Filter sign-red)
C1R	Printed circuit board	H4P	Light emitting diode (Defrost-orange)
F1U	Capacitor (M1F)	SS1	Selector switch (Main/sub)
H4P	Fuse (⑤: 5A, 250V)	SS2	Selector switch (Wireless address set)
KAR	Light emitting diode (Service monitor-green)		Connector for optional parts
M1F	Magnetic relay (L1S)	X8A	Connector (Float switch)
M1S	Magnetic relay (M1P)	X18A	Connector (Wiring adaptor for electrical appendices)
M1T	Motor (Indoor fan)	X23A	Connector (Infrared remote control)
M1U	Motor (Swing flap)		
M1V	Thermo switch (M1F embedded)		
M1W	Thermistor (Air)		
M1X	Thermistor (Coil liquid)		
M1Y	Thermistor (Coil gas)		
M1Z	Limit switch (Swing flap)		
T1R	Transformer (220-240V/22V)		
X1M	Terminal block (Power)		
X1N	Terminal block (Control)		
X1O	Electronic expansion valve		
X1P	Phase control circuit		
X1Q	Optional parts		
X1R	Motor (Drain pump)		
X1S	Wired remote control		
X1T	Thermistor (Air)		
X1U	Selector switch (Main/Sub)		
X1V	Receiver/Display unit (Attached to infrared remote control)		
X1W	Printed circuit board		
X1X	Push button (On/off)		
X1Y	Light emitting diode (On-red)		
X1Z	Light emitting diode (Timer-green)		

FXAQ20M / 25M / 32MVE / 40M / 50M / 63MVE

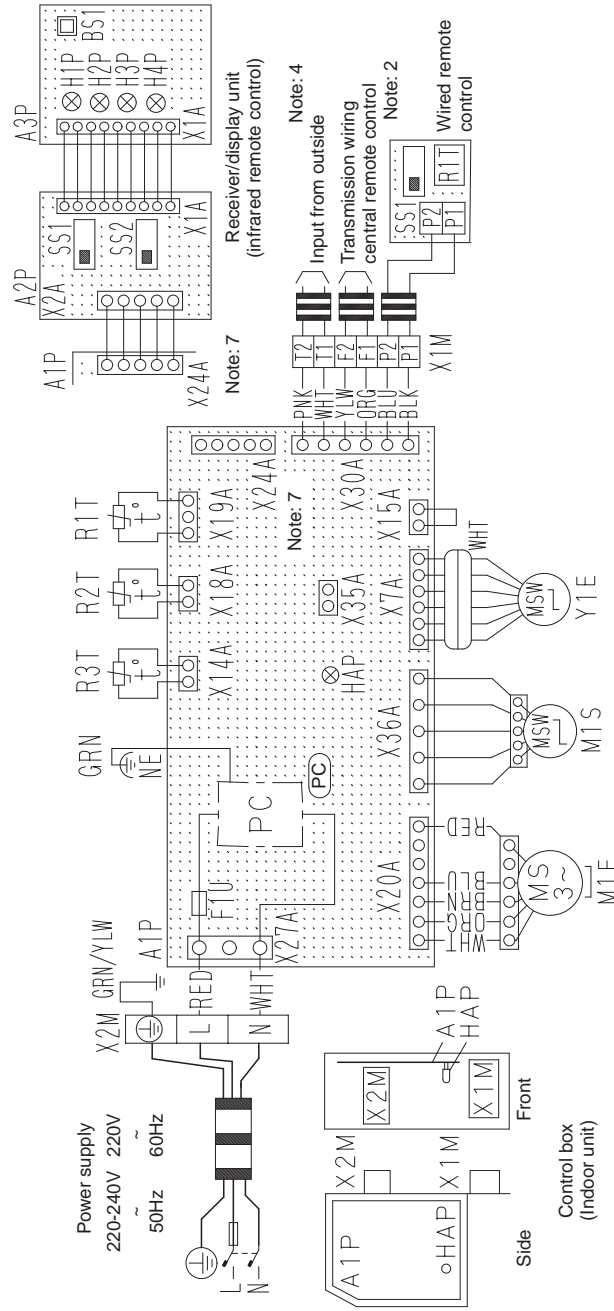

Indoor unit	
A1P	Printed circuit board
F1U	Fuse (®, 3A, 250V)
HAP	Light emitting diode (Service monitor-green)
M1S	Motor (Swing flap)
M1F	Motor (Indoor fan)
R1T	Thermistor (Air)
R2T	Thermistor (Coil liquid pipe)
R3T	Thermistor (Coil gas pipe)
X1M	Terminal block (Control)
X2M	Terminal block (Power)
Y1E	Electronic expansion valve
PC	Power circuit
Receiver/Display unit (Attached to infrared remote control)	
A2P	Printed circuit board
A3P	Printed circuit board
BS1	Push button (On/off)
H1P	Light emitting diode (On-red)
H2P	Light emitting diode (Timer-green)
H3P	Light emitting diode (Filter sign-red)
H4P	Light emitting diode (Defrost-orange)
SS1	Selector switch (Main/sub)
SS2	Selector switch (infrared remote control)

- Notes:
- □ □ □ : Terminal
  - ▬▬▬ : Field wiring
  - In case using central remote control, connect it to the unit in accordance with the attached installation manual.
  - Symbols shows as follows: RED: red, WHT: white, GRN: green, PNK: pink, YLW: yellow, BLK: black, ORG: orange, BRN: brown, BLU: blue
- When connecting the input wires from outside, forced off or on/off control operation can be selected by remote control. In details, refer to the installation manual attached the unit.
  - Remote control model varies according to the combination system, confirm engineering data and catalogs, etc. before connecting.
  - Confirm the method of setting the selector switch (SS1, SS2) of wired remote control and infrared remote control by installation manual and engineering data, etc.
  - X24A is connected when the wireless remote control kit is being used.

Connector for optional parts	
R1T	Thermistor (Air)
SS1	Selector switch (Main/sub)
	Connector (Float switch)
	Connector (Group control adaptor)

3D034206A



**FXLQ20M / 25M / 32M / 40M / 50M / 63MVE**  
**FXNQ20M / 25M / 32M / 40M / 50M / 63MVE**

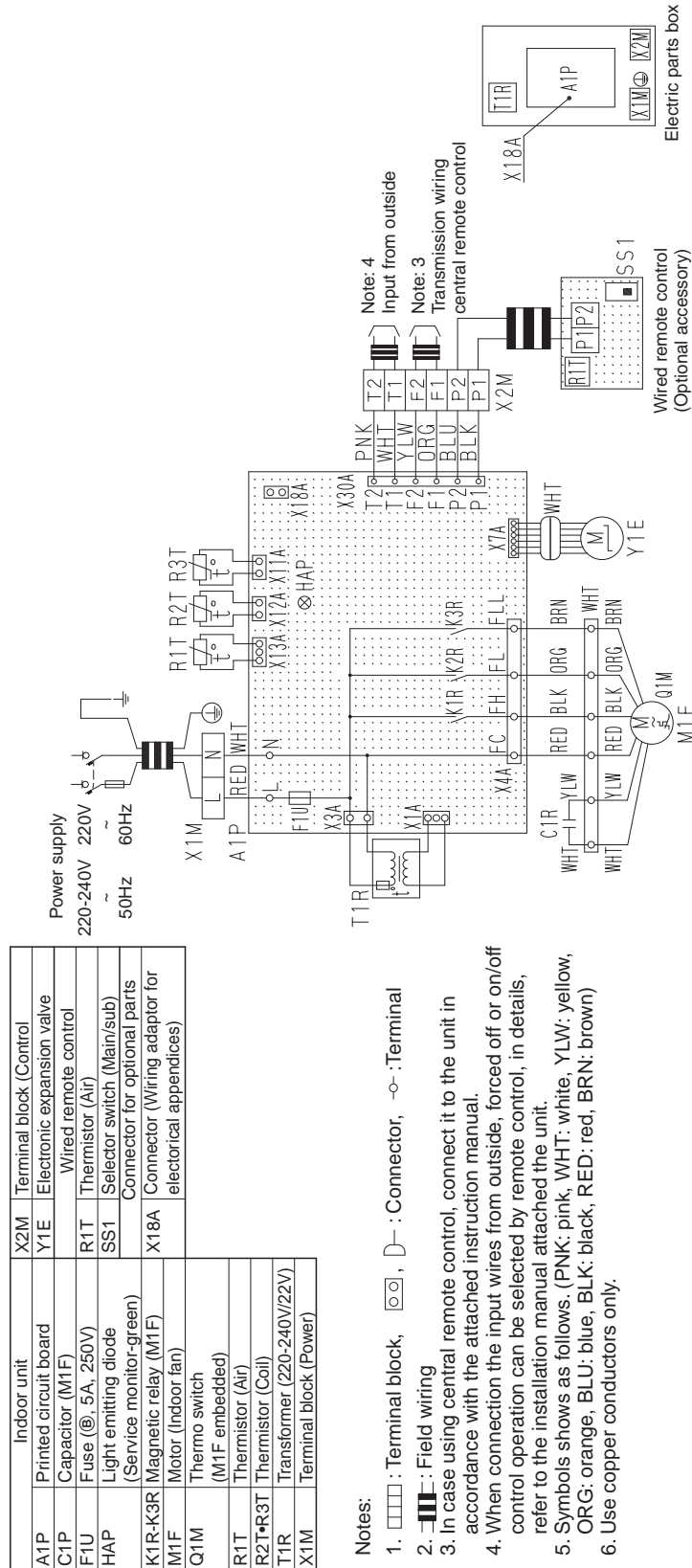

3D039826A

FXUQ71M / 100M / 125MV1

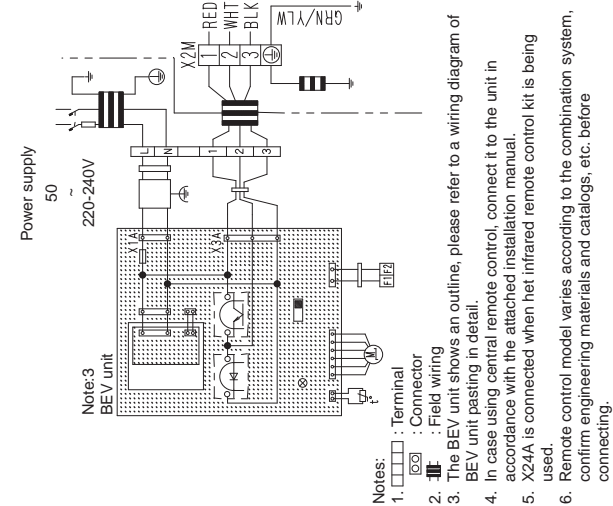
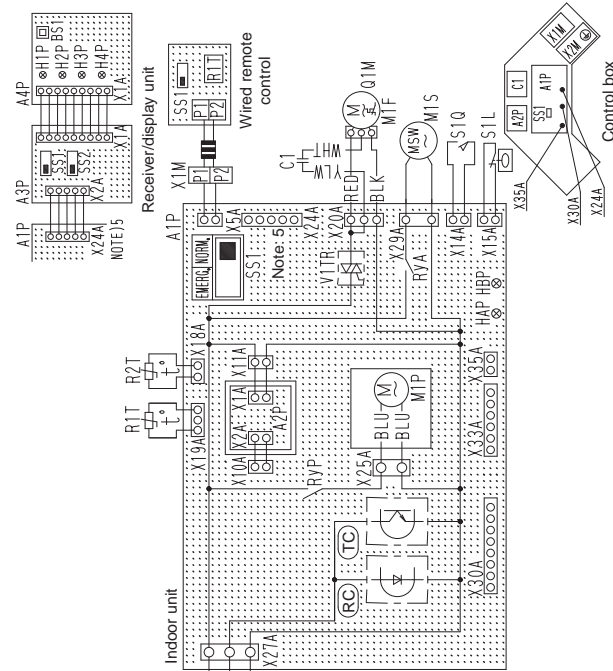

Indoor unit		Wired remote control	
A1P	Printed circuit board	R1T	Thermistor (Air)
A2P	Printed circuit board (Transformer 220-240V/16V)	SS1	Selector switch (Main/sub)
C1	Capacitor (M1F)		Receiver/display unit (Attached to infrared remote control)
HAP	Light emitting diode (Service monitor-green)	A3P	Printed circuit board
HBP	Light emitting diode (Service monitor-green)	A4P	Printed circuit board
M1S	Motor (Swing flap)	BS1	Push button (On/off)
M1F	Motor (Indoor fan)	H1P	Light emitting diode (On-red)
M1P	Motor (Drain pump)	H2P	Light emitting diode (Timer-green)
Q1M	Thermo switch (M1F embedded)	H3P	Light emitting diode (Filter sign-red)
R1T	Thermistor (Air)	H4P	Light emitting diode
R2T	Thermistor (Coil)	RVA	Magnetic relay (M1A)
RVA	Magnetic relay (M1A)	SS1	Selector switch (Main/sub)
RYP	Magnetic relay (M1P)	SS2	Selector switch (Infrared address set)
S1Q	Limit switch (Swing flap)		Connector for optional parts
S1L	Float switch	X24A	Connector (Infrared remote control)
SS1	Selector Switch (Emergency)	X30A	Connector (Interface adaptor for sky air series)
V1TR	Phase control circuit	X35A	Connector (Group control adaptor)
X1M	Terminal strip		
X2M	Terminal strip		
RC	Signal receiver		
TC	Signal transmission circuit		

- Notes:
1. □ : Terminal
  2. □ : Connector
  3. The BEV unit shows an outline, please refer to a wiring diagram of BEV unit pasting in detail.
  4. In case using central remote control, connect it to the unit in accordance with the attached installation manual.
  5. X24A is connected when the infrared remote control kit is being used.
  6. Remote control model varies according to the combination system, confirm engineering materials and catalogs, etc. before connecting.
  7. Confirm the method of setting the selector switch (SS1, SS2) of wired remote control and infrared remote control by installation manual and engineering data, etc.
  8. Symbols shows as follows: RED: red, BLK: black, WHT: white, YLW: yellow, GRN: green, BLU: blue.

3D044973

FXAQ20MH / 25MH / 32MH / 40MH / 50MHV1

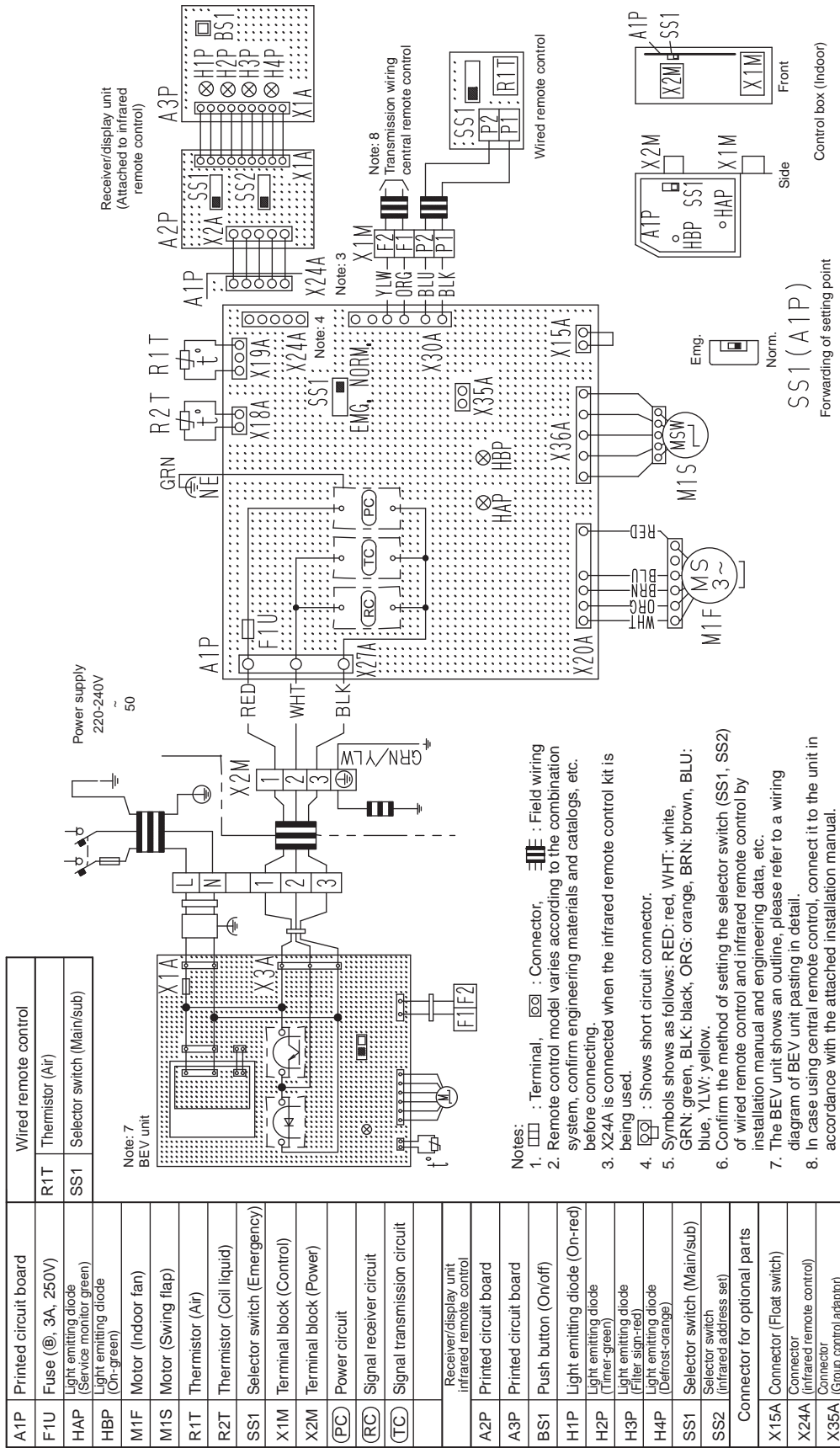

3D046348A

**FXLQ20MH / 25MH / 32MH / 40MH / 50MHV1**

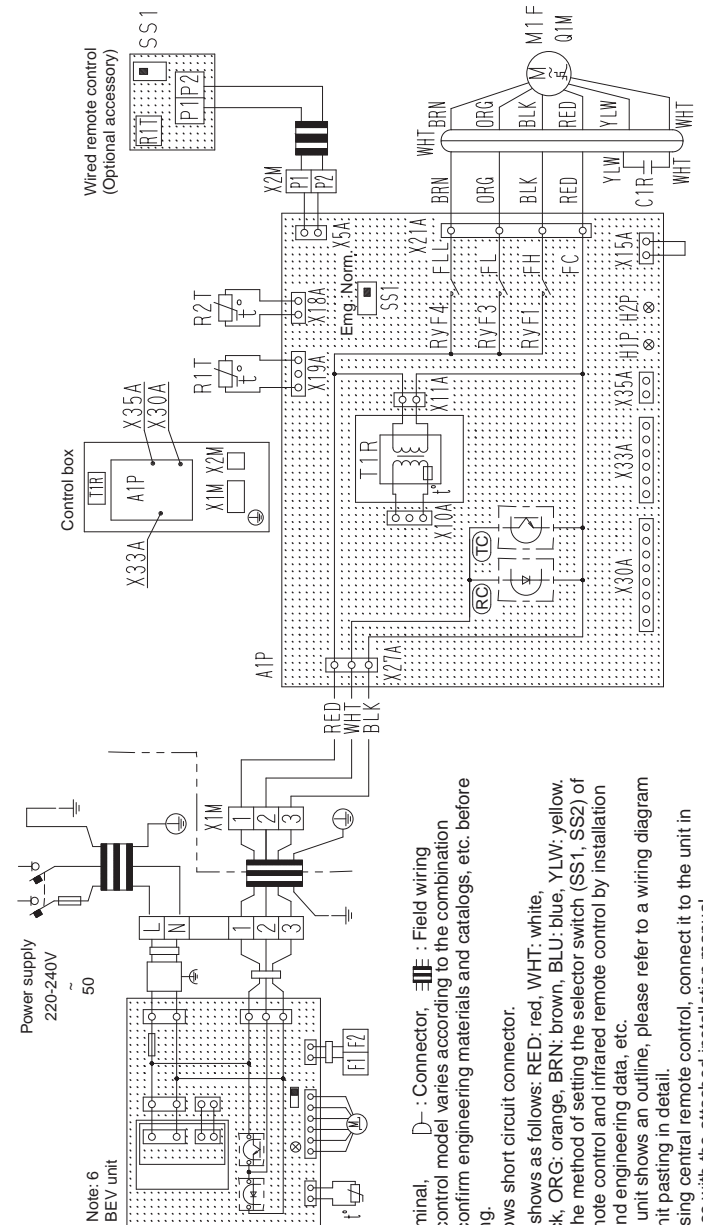

Indoor unit	
A1P	Printed circuit board
C1R	Capacitor (M1F)
H1P	Light emitting diode (Service monitor, green)
H2P	Light emitting diode (Service monitor, green)
M1F	Motor (Indoor fan)
Q1M	Thermo switch (135°) (M1F embedded)
R1T	Thermistor (Air)
R2T	Thermistor (Coil)
RVF1..3.4	Magnetic relay (M1F)
SS1	Selector switch (Emergency)
T1R	Transformer (220-240V/22V)
X1M	Terminal block (Power)
X2M	Terminal block (Control)
(RC)	Signal receiver circuit
(TC)	Signal transmission circuit
	Wired remote control
R1T	Thermistor (Air)
SS1	Selector switch (Main/sub)
Connector for optional parts	
X30A	Connector (Interface adaptor for sky air series)
X33A	Connector (Adaptor for wiring)
X35A	Connector (Group control adaptor)

- Notes:
1. □ : Terminal, D : Connector, : Field wiring
  2. Remote control model varies according to the combination system, confirm engineering materials and catalogs, etc. before connecting.
  3. : Shows short circuit connector.
  4. Symbols shows as follows: RED: red, WHT: white, BLK: black, ORG: orange, BRN: brown, BLU: blue, YLW: yellow.
  5. Confirm the method of setting the selector switch (SS1, SS2) of wired remote control and infrared remote control by installation manual and engineering data, etc.
  6. The BEV unit shows an outline, please refer to a wiring diagram of BEV unit pasting in detail.
  7. In case using central remote control, connect it to the unit in accordance with the attached installation manual.

3D046787A

FXMQ125MF / 200MF / 250MFV1

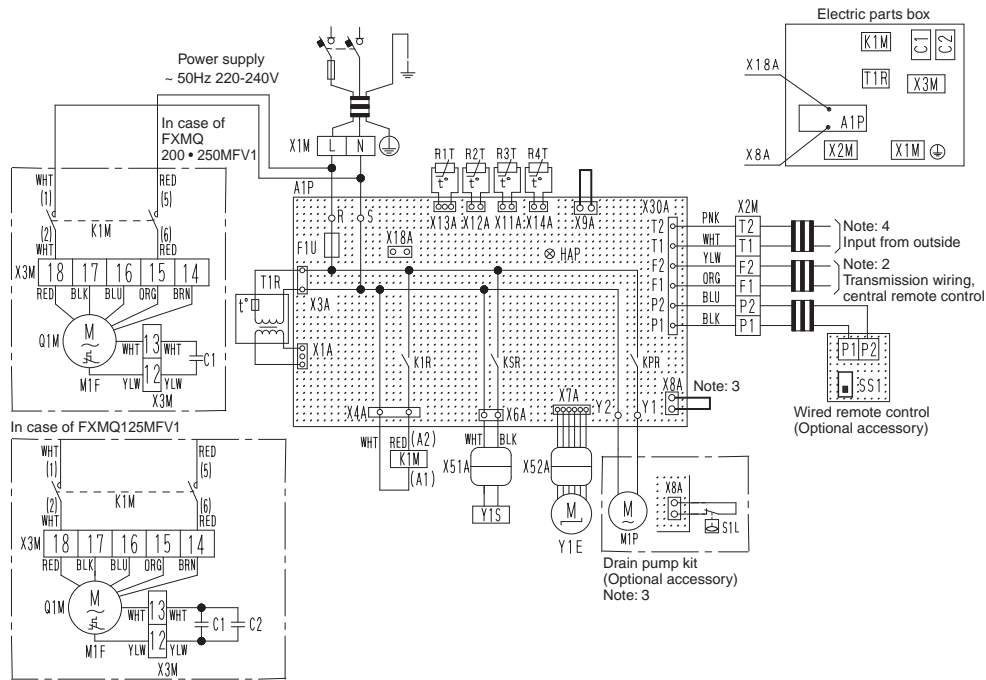

Indoor unit		X1M	Terminal block (Power)
A1P	Printed circuit board	X2M	Terminal block (Control)
C1, C2	Capacitor (M1F)	X3M	Terminal block
F1U	Fuse (⑤, 5A, 250V) (A1P)	X51A, X52A	Connector
HAP	Light emitting diode (Service monitor green)	Y1E	Electric expansion valve
K1M	Magnetic relay (M1F)	Y1S	solenoid valve (Hot gas)
K1R	Magnetic relay (M1F)	Optional parts	
KPR	Magnetic relay (M1P)	M1P	Motor (Drain pump)
KSR	Magnetic relay (Y1S)	S1L	Float switch (Drain pump)
M1F	Motor (Fan)	Wired remote control	
Q1M	Thermal protector (M1F embedded 135°C)	SS1	Selector switch (Main/sub)
R1T	Thermistor (Suction air)	Connector for optional parts	
R2T	Thermistor (Coil, liquid)	X18A	Connector (Wiring adaptor for electrical appendices)
R3T	Thermistor (Coil, gas)		
R4T	Thermistor (Discharge air)		
T1R	Transformer (220-240V/22V)		

Notes:

- : Terminal block, ⊞⊞ : Connector, ○—○ : Terminal, ⊞⊞ : Short circuit connector, ⊞⊞ : Field wiring.
- In case using central remote control, connect it to the unit in accordance with the attached installation manual.
- In case installing the drain pump kit, remove the short circuit connector of X8A and execute the additional wiring for float switch and drain pump.
- In case connecting the input wires from outside, forced off or on/off control operation can be selected by remote control. In details, refer to the installation manual attached to the unit.
- Do not remove short circuit connector of X9A.

3D04496B

## BEVQ50MVE

BEV unit	
A1P	Printed circuit board
A2P	Power supply printed circuit board assy (220-240V/16V)
F1U	Fuse (⊗, 10A, 250V)
HAP	Light emitting diode (Service monitor-green)
R3T	Thermistor (Gas)
SS1	Selector switch (M/S)
X1M	Terminal strip (Power)
X2M	Terminal strip (Transmission)
Y1E	Electronic expansion valve
Z1C • Z2C Z3C • Z4C	Noise filter

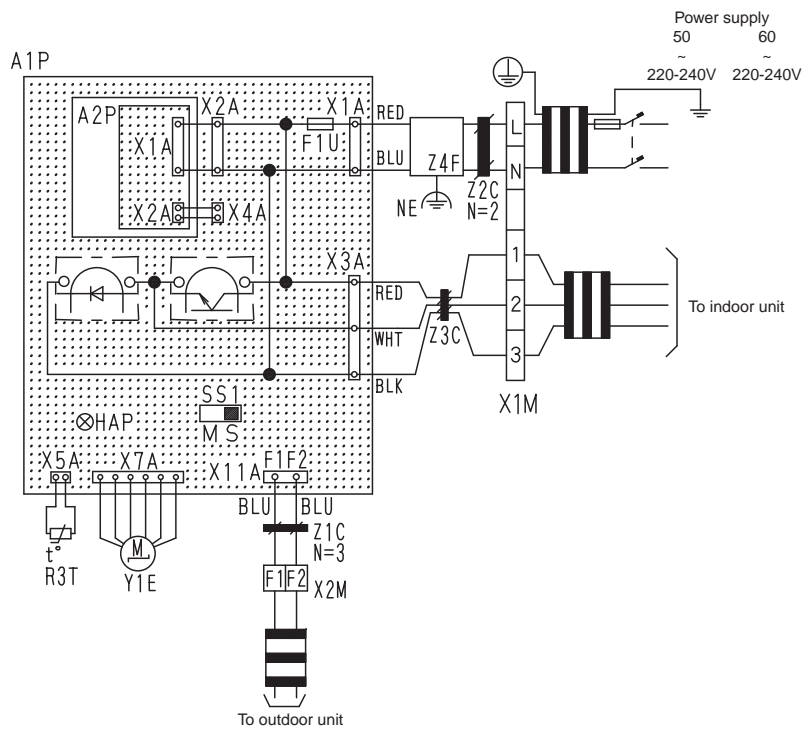
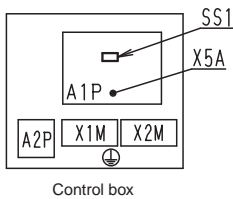

## Notes:

- : Terminal, □○□ : Connector
- ≡≡≡ : Field wiring.
- This wiring diagram only shows the BEV unit.  
See the wiring diagrams and installation manuals for the wiring and settings for the indoor, outdoor.
- See the indoor unit's wiring diagram when installing optional parts for the indoor unit.
- Only one indoor unit may be connected to the BEV unit.  
See the indoor unit's wiring diagram for when connecting the remote control.
- Always use the sky air connection adapter for the indoor unit when using a central control unit.  
Refer to the manual attached the unit when connecting. (In FXAQ-MHV1, it is unnecessary.)
- Cool/heat changeover of indoor units connected to BEV unit cannot be carried out.  
In case of a system with BEV unit only, cool/heat selector is required.
- Connect the attached thermistor to the R3T.
- Symbols show as follows. (BLU: blue, RED: red, WHT: white, BLK: black)

3D046579A

BEVQ71M / 100M / 125MVE

BEV unit	
A1P	Printed circuit board assy
A2P	Power supply printed circuit board assy (220-240V/16V)
F1U	Fuse (⊗, 10A, 250V)
HAP	Light emitting diode (Service monitor-green)
R3T	Thermistor (Gas)
SS1	Selector switch (M/S)
X1M	Terminal strip (Power)
X2M	Terminal strip (Transmission)
Y1E	Electronic expansion valve
Z1C • Z2C Z3C • Z4C	Noise filter

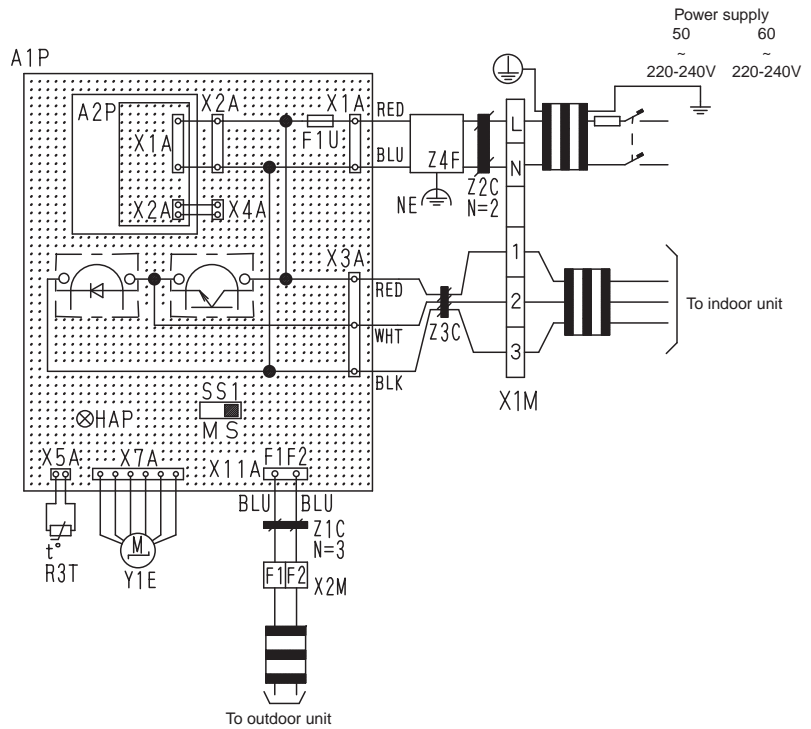
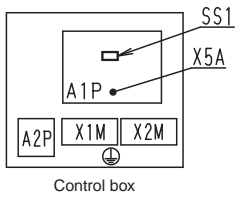

Notes:

1. : Terminal, : Connector
2. : Field wiring.
3. This wiring diagram only shows the BEV unit.  
See the wiring diagrams and installation manuals for the wiring and settings for the indoor, outdoor, and BS units.
4. See the indoor unit's wiring diagram when installing optional parts for the indoor unit.
5. Only one indoor unit may be connected to the BEV unit.  
See the indoor unit's wiring diagram for when connecting the remote control.
6. Always use the sky air connection adapter for the indoor unit when using a central control unit.  
Refer to the manual attached the unit when connecting.
7. Cool/heat changeover of indoor units connected to BEV unit cannot be carried out unless they are connected to BS unit.  
In case of a system with BEV unit only, cool/heat selector is required.
8. Set the SS1 to "M" only for the BEV unit connected to the indoor unit which is to have cool/heat switching capability, when connecting the BS unit.  
The "M/S" on the SS1 stands for "Main/sub".  
This is set to "S" when shipped from the factory.
9. Connect the attached thermistor to the R3T.
10. Symbols show as follows. (BLU: blue, RED: red, WHT: white, BLK: black)

3D044901A

## 3. List of Electrical and Functional Parts

### 3.1 Outdoor Unit

#### 3.1.1 RXYQ5~16MY1B

※ Valve in ( ) are for RXYQ5MY1B

Item	Name		Symbol	Model		
				RXYQ5MY1B	RXYQ8MY1B	RXYQ10MY1B
Compressor	Inverter	Type	M1C	JT1FCVDKYR 3.2kW	JT1FCVDKTYR 1.2kW	JT1FCVDKTYR 2.7kW
		Output				
	STD.1	Type	M2C	—	JT170FCKYE 4.5kW	JT170FCKYE 4.5kW
		Output				
	STD.2	Type	M3C	—		
		Output				
	Crankcase heater (INV)		E1HC	240V 33W		
	Crankcase heater (STD.1)		E2HC	—	240V 33W	
Crankcase heater (STD.2)		E3HC	—			
OC protection device for STD compressor		—	—	15A		
Fan motor	Motor		M1F	0.35kw	0.75kw	
	OC protection device		—	1.6A	3.2A	
Functional parts	Electronic expansion valve (Main)	Cooling	Y1E	1400pls	PI control	
		Heating				
	Electronic expansion valve (Subcool)	Cooling	Y2E	—	PI control	
		Heating				
	Solenoid valve (Hot gas)		Y1S	TEV1620DQ2		
	Solenoid valve (External multi oil)		Y2S	—	TEV1620DQ2	
	Solenoid valve (Receiver gas discharge)		Y3S (Y2S)	VPV-603D		
	Solenoid valve (Non-operating unit liquid pipe close)		Y4S	—	VPV-803DXF	
	4 way valve		Y5S (Y3S)	VHV0310	VT40110	
	Solenoid valve (Injection)		(Y4S)	TEV1620DQ2	—	
Pressure-related parts	Pressure switch (INV)		S1PH	PS80 ON : 3.8+0/-0.15MPa OFF : 2.85±0.15MPa		
	Pressure switch (STD1)		S2PH	—	PS80 ON : 3.8+0/-0.15MPa OFF : 2.85±0.15MPa	
	Pressure switch (STD2)		S3PH	—		
	Fusible plug		—	FPGD-3D 70 to 75°C		
	Pressure sensor (HP)		S1NPH	PS8051A 0 to 4.15MPa		
	Pressure sensor (LP)		S1NPL	PS8051A -0.1 to 1.7MPa		
Thermistor	INV PCB	For fin	R1T	3.5 to 360Ω		
	Main PCB	For outdoor air	R1T	3.5 to 360Ω		
		For suction pipe	R2T	3.5 to 360Ω		
		For discharge pipe (INV)	R31T (R3T)	3.5 to 400Ω		
		For discharge pipe (STD.1)	R32T	3.5 to 400Ω		
		For discharge pipe (STD.2)	R33T	3.5 to 400Ω		
		For heat exchanger	R4T	3.5 to 360Ω		
		For subcooling heat exchanger	R5T	3.5 to 360Ω		
		For receiver liquid pipe	R6T	3.5 to 360Ω		
For oil equalizing pipe	R7T	3.5 to 360Ω				
Others	Fuse (A1P)		F1, 2U	250VAC 10A Class B		



Item	Name		Symbol	Model		
				RXYQ12MY1B	RXYQ14MY1B	RXYQ16MY1B
Compressor	Inverter	Type	M1C	JT1FCVDKTYR 4.2kW	JT1FCVDKTYR 2.0kW	JT1FCVDKTYR 3.0kW
		Output				
	STD.1	Type	M2C	JT170FCKYE 4.5kW	JT170FCKYE 4.5kW	JT170FCKYE 4.5kW
		Output				
	STD.2	Type	M3C	—	JT170FCKYE 4.5kW	JT170FCKYE 4.5kW
		Output				
	Crankcase heater (INV)		E1HC	240V 33W		
	Crankcase heater (STD.1)		E2HC	240V 33W		
Crankcase heater (STD.2)		E3HC	—	240V 33W		
OC protection device for STD compressor		—	15A			
Fan motor	Motor		M1F	0.75kw		
	OC protection device		—	3.2A		
Functional parts	Electronic expansion valve (Main)	Cooling	Y1E	0pls		
		Heating		PI control		
	Electronic expansion valve (Subcool)	Cooling	Y2E	PI control		
		Heating		0pls		
	Solenoid valve (Hot gas)		Y1S	TEV1620DQ2		
	Solenoid valve (External multi oil)		Y2S	TEV1620DQ2		
	Solenoid valve (Receiver gas discharge)		Y3S	VPV-603D		
	Solenoid valve (Non-operating unit liquid pipe close)		Y4S	VPV-803DXF		
	4 way valve		Y5S	VT40110	VT60100	
Pressure-related parts	Pressure switch (INV)		S1PH	PS80 ON : 3.8+0/-0.15MPa OFF : 2.85±0.15MPa		
	Pressure switch (STD1)		S2PH	PS80 ON : 3.8+0/-0.15MPa OFF : 2.85±0.15MPa		
	Pressure switch (STD2)		S3PH	—	PS80 ON : 3.8+0/-0.15MPa OFF : 2.85±0.15MPa	
	Fusible plug		—	FPGD-3D 70 to 75°C		
	Pressure sensor (HP)		S1NPH	PS8051A 0 to 4.15MPa		
	Pressure sensor (LP)		S1NPL	PS8051A -0.1 to 1.7MPa		
Thermistor	INV PCB	For fin	R1T	3.5 to 360Ω		
		Main PCB	For outdoor air	R1T	3.5 to 360Ω	
	For suction pipe		R2T	3.5 to 360Ω		
	For discharge pipe (INV)		R31T	3.5 to 400Ω		
	For discharge pipe (STD.1)		R32T	3.5 to 400Ω		
	For discharge pipe (STD.2)		R33T	3.5 to 400Ω		
	For heat exchanger		R4T	3.5 to 360Ω		
	For subcooling heat exchanger		R5T	3.5 to 360Ω		
	For receiver liquid pipe		R6T	3.5 to 360Ω		
For equalizing pipe	R7T	3.5 to 360Ω				
Others	Fuse (A1P)		F1, 2U	250VAC 10A Class B		

## 3.2 Indoor Side

### 3.2.1 Indoor Unit

Parts Name		Symbol	Model							Remark
			FXFQ25 MVE	FXFQ32 MVE	FXFQ40 MVE	FXFQ50 MVE	FXFQ63 MVE	FXFQ80 MVE	FXFQ100 MVE	
Remote Controller	Wired Remote Controller		BRC1A61							Option
	Wireless Remote Controller		BRC7E61W							Option
Motors	Fan Motor	M1F	DC380V 30W 8P					DC 380V 120W 8P		
	Drain Pump	M1P	AC220-240V (50Hz) AC220V (60Hz) PLD-12230DM Thermal Fuse 145°C							
	Swing Motor	M1S	MP35HCA[3P007482-1] Stepping Motor DC16V							
Thermistors	Thermistor (Suction Air)	R1T	In PCB A4P or wired remote controller							
	Thermistor (for Heat Exchanger High Temp.)	R3T	ST8605-5 $\phi$ 8 L1000 20k $\Omega$ (25°C)							
	Thermistor (Heat Exchanger)	R2T	ST8602A-5 $\phi$ 6 L1000 20k $\Omega$ (25°C)							
Others	Float Switch	S1L	FS-0211B							
	Fuse	F1U	250V 5A $\phi$ 5.2							
	Thermal Fuse	TFu	—							
	Transformer	T1R	—							

Parts Name		Symbol	Model							Remark
			FXCQ 20MVE	FXCQ 25MVE	FXCQ 32MVE	FXCQ 40MVE	FXCQ 50MVE	FXCQ 63MVE	FXCQ 80MVE	
Remote Controller	Wired Remote Controller		BRC1A61							Option
	Wireless Remote Controller		BRC7C62							Option
Motors	Fan Motor	M1F	AC 220~240V 50Hz							
			1 $\phi$ 10W	1 $\phi$ 15W	1 $\phi$ 20W	1 $\phi$ 30W	1 $\phi$ 50W	1 $\phi$ 85W		
			Thermal Fuse 152°C			—	Thermal protector 135°C : OFF 87°C : ON			
Motors	Drain Pump	M1P	AC220-240V (50Hz) AC220V (60Hz) PLD-12230DM Thermal Fuse 145°C							
	Swing Motor	M1S	MT8-L[3PA07509-1] AC200~240V							
	Thermistors	Thermistor (Suction Air)	R1T	ST8601-6 $\phi$ 4 L1250 20k $\Omega$ (25°C)						
Thermistor (for Heat Exchanger High Temp.)		R3T	ST8605-6 $\phi$ 8 L1250 20k $\Omega$ (25°C)							
Thermistor (Heat Exchanger)		R2T	ST8602A-5 $\phi$ 6 L1000 20k $\Omega$ (25°C)							
Others	Float Switch	S1L	FS-0211B							
	Fuse	F1U	250V 5A $\phi$ 5.2							
	Transformer	T1R	TR22H21R8							

Parts Name		Symbol	Model					Remark
			FXZQ 20MVE	FXZQ 25MVE	FXZQ 32MVE	FXZQ 40MVE	FXZQ 50MVE	
Remote Controller	Wired Remote Controller		BRC1A61					Option
	Wireless Remote Controller		BRC7E530W					
Motors	Fan Motor	M1F	AC 220~240V 50Hz					
			1φ55W 4P					
			Thermal Fuse 135°C					
	Capacitor, fan motor	C1	4.0μ F 400VAC					
	Drain Pump	M1P	AC220-240V (50Hz) PLD-12230DM Thermal Fuse 145°C					
Swing Motor	M1S	MP35HCA [3P080801-1] AC200~240V						
Thermistors	Thermistor (Suction Air)	R1T	ST8601A-1 φ4 L250 20kΩ (25°C)					
	Thermistor (for Heat Exchanger High Temp.)	R3T	ST8605-3 φ8 L630 20kΩ (25°C)					
	Thermistor (Heat Exchanger)	R2T	ST8602A-3 φ6 L630 20kΩ (25°C)					
Others	Float Switch	S1L	FS-0211					
	Fuse	F1U	250V 5A φ5.2					
	Transformer	T1R	TR22H21R8					

Parts Name		Symbol	Model				Remark	
			FXKQ 25MVE	FXKQ 32MVE	FXKQ 40MVE	FXKQ 63MVE		
Remote Controller	Wired Remote Controller		BRC1A61				Option	
	Wireless Remote Controller		BRC4C61					
Motors	Fan Motor	M1F	AC 220~240V 50Hz					
			1φ15W 4P		1φ20W 4P	1φ45W 4P		
			Thermal Fuse 146°C		Thermal protector 120°C : OFF 105°C : ON			
	Drain Pump	M1P	AC 220-240V (50Hz) PLD-12200DM Thermal Fuse 145°C					
Swing Motor	M1S	MP35HCA [3P080801-1] AC200~240V						
Thermistors	Thermistor (Suction Air)	R1T	ST8601-13 φ4 L630 20kΩ (25°C)					
	Thermistor (for Heat Exchanger High Temp.)	R3T	ST8605-7 φ8 L1600 20kΩ (25°C)					
	Thermistor (Heat Exchanger)	R2T	ST8602A-7 φ6 L1600 20kΩ (25°C)					
Others	Float Switch	S1L	FS-0211B					
	Fuse	F1U	250V 5A φ5.2					
	Transformer	T1R	TR22H21R8					

Parts Name		Symbol	Model						Remark
			FXDQ 20MVE	FXDQ 25MVE	FXDQ 32MVE	FXDQ 40MVE	FXDQ 50MVE	FXDQ 63MVE	
Remote Controller	Wired Remote Controller		BRC1A62						Option
	Wireless Remote Controller		BRC4C62						
Motors	Fan Motor	M1F	AC 220~240V 50Hz						
			1φ62W			1φ130W			
	Thermal protector 130°C: OFF, 83°C: ON								
	Drain Pump	M1P	AC220-240V (50Hz) PLD-1223ODM Thermal Fuse 145°C						
Thermistors	Thermistor (Suction Air)	R1T	ST8601-1 φ4 L=250 20kΩ (25°C)						
	Thermistor (for Heat Exchanger High Temp.)	R3T	ST8605-4 φ8 L=800 20kΩ (25°C)						
	Thermistor (Heat Exchanger)	R2T	ST8602A-4 φ6 L=800 20kΩ (25°C)						
Others	Float Switch	S1L	FS-0211E						
	Fuse	F1U	250V 5A φ5.2						
	Transformer	T1R	TR22H21R8						

Parts Name		Symbol	Model									Remark
			FXSQ 20MVE	FXSQ 25MVE	FXSQ 32MVE	FXSQ 40MVE	FXSQ 50MVE	FXSQ 63MVE	FXSQ 80MVE	FXSQ 100MVE	FXSQ 125MVE	
Remote Controller	Wired Remote Controller		BRC1A62									Option
	Wireless Remote Controller		BRC4C62									
Motors	Fan Motor	M1F	AC 220~240V 50Hz									
			1φ50W			1φ65W	1φ85W	1φ125W	1φ225W			
	Thermal Fuse 152°C						Thermal protector 135°C : OFF 87°C : ON					
	Drain Pump	M1P	AC220-240V (50Hz) PLD-1223ODM Thermal Fuse 145°C									
Thermistors	Thermistor (Suction Air)	R1T	ST8601-4 φ4 L800 20kΩ (25°C)									
	Thermistor (for Heat Exchanger High Temp.)	R3T	ST8605-7 φ8 L1600 20kΩ (25°C)									
	Thermistor (Heat Exchanger)	R2T	ST8602A-6 φ6 L1250 20kΩ (25°C)									
Others	Float Switch	S1L	FS-0211B									
	Fuse	F1U	250V 5A φ5.2									
	Transformer	T1R	TR22H21R8									

Parts Name		Symbol	Model							Remark
			FXMQ 40MVE	FXMQ 50MVE	FXMQ 63MVE	FXMQ 80MVE	FXMQ 100MVE	FXMQ 125MVE	FXMQ 200MVE	
Remote Controller	Wired Remote Controller		BRC1A62							Option
	Wireless Remote Controller		BRC4C62							
Motors	Fan Motor	M1F	AC 220~240V 50Hz							
			1φ100W	1φ160W	1φ270W	1φ430W	1φ380W×2			
	Thermal protector 135°C : OFF 87°C : ON									
	Capacitor for Fan Motor	C1R	5μ F-400V	7μ F 400V	10μ F 400V	8μ F 400V	10μ F 400V	12μ F 400V		
Thermistors	Thermistor (Suction Air)	R1T	ST8601A-5 φ4 L1000 20kΩ (25°C)				ST8601A-13 φ4 L630			
	Thermistor (for Heat Exchanger High Temp.)	R3T	ST8605A-4 φ8 L800 20kΩ (25°C)				ST8605A-5 φ8 L1000			
	Thermistor (Heat Exchanger)	R2T	ST8602A-4 φ6 L800 20kΩ (25°C)				ST8602A-6 φ6 L1250			
Others	Float switch	S1L	FS-0211							
	Fuse	F1U	250V 5A φ5.2		250V 10A φ5.2		250V 10A			
	Transformer	T1R	TR22H21R8							

Parts Name		Symbol	Model			Remark
			FXHQ 32MVE	FXHQ 63MVE	FXHQ 100MVE	
Remote Controller	Wired Remote Controller		BRC1A61			Option
	Wireless Controller		BRC7E63W			
Motors	Fan Motor	M1F	AC 220~240V/220V 50Hz/60Hz			
			1φ63W	1φ130W		
	Thermal protector 130°C : OFF 80°C : ON					
	Capacitor for Fan Motor	C1R	3.0μF-400V		9.0μF-400V	
	Swing Motor	M1S	MT8-L[3P058751-1] AC200~240V			
Thermistors	Thermistor (Suction Air)	R1T	ST8601A-1 φ4 L250 20kΩ (25°C)			
	Thermistor (for Heat Exchanger High Temp.)	R3T	ST8605-6 φ8 L = 1250 20kΩ (25°C)		ST8605-6 φ8 L = 1250 20kΩ (25°C)	
	Thermistor (Heat Exchanger)	R2T	ST8602A-6 φ6 L = 1250 20kΩ (25°C)		ST8602A-6 φ6 L = 1250 20kΩ (25°C)	
Others	Fuse	F1U	250V 5A φ5.2			
	Transformer	T1R	TR22H21R8			

Parts Name		Symbol	Model					Remark
			FXAQ 20MVE	FXAQ 25MVE	FXAQ 32MVE	FXAQ 40MVE	FXAQ 50MVE	
Remote Controller	Wired Remote Controller		BRC1A61					Option
	Wireless Remote Controller		BRC7E618					
Motors	Fan Motor	M1F	AC 220~240V 50Hz					
			1φ40W	1φ43W				
	Thermal protector 130°C : OFF 80°C : ON							
	Swing Motor	M1S	MP24[3SB40333-1] AC200~240V		MSFBC20C21 [3SB40550-1] AC200~240V			
Thermistors	Thermistor (Suction Air)	R1T	ST8601-2 φ4 L400 20kΩ (25°C)					
	Thermistor (for Heat Exchanger High Temp.)	R3T	ST8605-2 φ8 L400 20kΩ (25°C)					
	Thermistor (for Heat Exchanger)	R2T	ST8602-2 φ6 L400 20kΩ (25°C)					
Others	Float Switch	S1L	OPTION					
	Fuse	F1U	250V 5A φ5.2					

Parts Name		Symbol	Model					Remark
			FXLQ 20MVE	FXLQ 25MVE	FXLQ 32MVE	FXLQ 40MVE	FXLQ 50MVE	
Remote Controller	Wired Remote Controller		BRC1A62					Option
	Wireless Remote Controller		BRC4C62					
Motors	Fan Motor	M1F	AC 220~240V 50Hz					
			1φ15W	1φ25W	1φ35W			
	Capacitor for Fan Motor	C1R	1.0μF-400V	0.5μF-400V	1.0μF-400V	1.5μF-400V	2.0μF-400V	
Thermistors	Thermistor (Suction Air)	R1T	ST8601-6 φ4 L1250 20kΩ (25°C)					
	Thermistor (for Heat Exchanger High Temp.)	R3T	ST8605-9 φ8 L2500 20kΩ (25°C)					
	Thermistor (for Heat Exchanger)	R2T	ST8602A-9 φ6 L2500 20kΩ (25°C)					
Others	Fuse	F1U	AC250V 5A					
	Transformer	T1R	TR22H21R8					

Parts Name		Symbol	Model					Remark
			FXNQ 20MVE	FXNQ 25MVE	FXNQ 32MVE	FXNQ 40MVE	FXNQ 50MVE	
Remote Controller	Wired Remote Controller		BRC1A62					Option
	Wireless Remote Controller		BRC4C62					
Motors	Fan Motor	M1F	AC 220~240V 50Hz					
			1φ15W	1φ25W	1φ35W			
	Capacitor for Fan Motor	C1R	1.0μF-400V	0.5μF-400V	1.0μF-400V	1.5μF-400V	2.0μF-400V	
Thermistors	Thermistor (Suction Air)	R1T	ST8601-6 φ4 L1250 20kΩ (25°C)					
	Thermistor (for Heat Exchanger High Temp.)	R3T	ST8605-9 φ8 L2500 20kΩ (25°C)					
	Thermistor (for Heat Exchanger)	R2T	ST8602A-9 φ6 L2500 20kΩ (25°C)					
Others	Fuse	F1U	AC250V 5A					
	Transformer	T1R	TR22H21R8					

Parts Name		Symbol	Model			Remark
			FXUQ71MV1	FXUQ100MV1	FXUQ125MV1	
Remote Controller	Wired Remote Controller		BRC1A61			Option
	Wireless Remote Controller		BRC7C528W			Option
Motors	Fan Motor	M1F	AC 220~240V 50Hz			
			1 $\phi$ 45W	1 $\phi$ 90W		
			Thermal protector 130°C	Thermal protector 130°C : OFF 83°C : ON		
	Drain Pump	M1P	AC220-240V (50Hz) AC220V (60Hz) PJV-1426			
Swing Motor	M1S	MT8-L[3PA07572-1] AC200~240V				
Thermistors	Thermistor (Suction Air)	R1T	ST8601-1 $\phi$ 4 L=250 20k $\Omega$ (25°C)			
	Thermistor (Heat Exchanger)	R2T	ST8602A-4 $\phi$ 6 L=800 20k $\Omega$ (25°C)			
Others	Float Switch	S1L	FS-0211B			

Parts Name		Symbol	Model			Remark
			FXMQ125MFV1	FXMQ200MFV1	FXMQ250MFV1	
Remote Controller	Wired Remote Controller		BRC1A62			Option
	Wireless Remote Controller		—			
Motors	Fan Motor	M1F	AC200~240V 50Hz			
			1 $\phi$ 380W			
			Thermal protector 135°C : OFF 87°C : ON			
	Capacitor for Fan Motor	C1R	10 $\mu$ F 400V $\times$ 2	10 $\mu$ F 400V	16 $\mu$ F 400V	
Solenoid valve	Solenoid valve (Hot gas)	Y1S	Body: VPV-603D Coil: NEV-MOAJ532C1 AC220-240V			
Thermistors	Thermistor (Suction Air)	R1T	ST8601-13 $\phi$ 4 L=630 20k $\Omega$ (25°C)			
	Thermistor (for Heat Exchanger High Temp.)	R3T	ST8605-6 $\phi$ 8 L=1250 20k $\Omega$ (25°C)			
	Thermistor (Heat Exchanger)	R2T	ST8602A-2 $\phi$ 6 L=1250 20k $\Omega$ (25°C)			
	Thermistor (for discharge air)	R4T	ST8605-8 L=2000 20k $\Omega$ (25°C)			
Others	Float switch	S1L	Option			
	Fuse	F1U	250V 5A $\phi$ 5.2			
	Transformer	T1R	TR22H21R8			

## 4. Option List

### 4.1 Option List of Controllers

#### Operation Control System Optional Accessories

No.	Item	Type	FXCQ-M	FXFQ-M	FXZQ-M	FXKQ-M	FXDQ	FXUQ-M	FXSQ-M	FXMQ-M	FXHQ-M	FXAQ-M(H)	FXLQ-M(H) FXNQ-M	FXMQ-MF	
		1	Remote controller	Wireless	BRC7C62	BRC7E61W	BRC7E530W	BRC4C61	BRC4C62	BRC7C528W	BRC4C62	BRC7E63W	BRC7E618	BRC4C62	—
		Wired	BRC1A61				BRC1A62	BRC1A61	BRC1A62	BRC1A61		BRC1A62			
2	Set back time clock	BRC15A61												—	
3	Simplified remote controller	—				BRC2A51	—	BRC2A51	—		BRC2A51	—			
4	Remote controller for hotel use	—				BRC3A61	—	BRC3A61	—		BRC3A61	—			
5	Adaptor for wiring	HKRP1B61	HKRP1B59	HKRP1B57	KRP1B61	HKRP1B56	—	KRP1B61	KRP1B3	—	KRP1B61				
6-1	Wiring adaptor for electrical appendices (1)	HKRP2A61	HKRP2A62	HKRP2A62	KRP2A61	HKRP2A53	HKRP2A62	KRP2A61	HKRP2A62	HKRP2A61	KRP2A61				
6-2	Wiring adaptor for electrical appendices (2)	HKRP4A51	HKRP4A53	HKRP4A53	KRP4A51	HKRP4A54	HKRP4A53	KRP4A51	HKRP4A52	HKRP4A51	KRP4A51				
7	Remote sensor	KRCS01-1	—	KRCS01-1										—	
8	Installation box for adaptor PCB	Note 2, 3 KRP1B96	Note 2, 3 KRP1D98	Note 4, 6 KRP1B101	—	Note 4, 6 KRP1B101	KRP1B97	Note 5 KRP4A91	—	Note 3 KRP1C93	Note 2, 3 KRP4A93	—	—		
9	Central remote controller	DCS302C61													
9-1	Electrical box with earth terminal (3 blocks)	KJB311A													
10	Unified on/off controller	DCS301B61													
10-1	Electrical box with earth terminal (2 blocks)	KJB212A													
10-2	Noise filter (for electromagnetic interface use only)	KEK26-1													
11	Schedule timer	DST301B61													
12	External control adaptor for outdoor unit (Must be installed on indoor units)	<sup>H</sup> DTA104A61	HDTA104A62	DTA104A61	<sup>H</sup> DTA104A53	—	DTA104A61	<sup>H</sup> DTA104A62	<sup>H</sup> DTA104A61	DTA104A61					

#### Note

1. Installation box (No.8) is necessary for each adaptor marked H.
2. Up to 2 adaptors can be fixed for each installation box.
3. Only one installation box can be installed for each indoor unit.
4. Up to 2 installation boxes can be installed for each indoor unit.
5. Installation box (No. 8) is necessary for second adaptor.
6. Installation box (No. 8) is necessary for each adaptor.

#### Various PC Boards

No.	Part name	Model No.	Function
1	Adaptor for wiring	KRP1B56 KRP1B57 KRP1B59 KRP1B61 KRP1B3	■ PC board when equipped with auxiliary electric heater in the indoor unit.
2	DIII-NET Expander Adaptor	DTA109A51	■ Up to 1024 units can be centrally controlled in 64 different groups. ■ Wiring restrictions (max. length: 1000m, total wiring length: 2000m, max. number of branches: 16) apply to each adaptor.



## System Configuration

No.	Part name	Model No.	Function
1	Central remote controller	DCS302C61	■ Up to 64 groups of indoor units (128 units) can be connected, and ON/OFF, temperature setting and monitoring can be accomplished individually or simultaneously. Connectable up to "2" controllers in one system.
2	Unified ON/OFF controller	DCS301B61	■ Up to 16 groups of indoor units (128 units) can be turned, ON/OFF individually or simultaneously, and operation and malfunction can be displayed. Can be used in combination with up to 8 controllers.
3	Schedule timer	DST301B61	■ Programmed time weekly schedule can be controlled by unified control for up to 64 groups of indoor units (128 units). Can turn units ON/OFF twice per day.
4	Unification adaptor for computerized control	HDCS302A52	■ Interface between the central monitoring board and central control units
5	Interface adaptor for SkyAir-series	HDTA102A52	■ Adaptors required to connect products other than those of the VRV System to the high-speed DIII-NET communication system adopted for the VRV System.
6	Central control adaptor kit	HDTA107A55	
7	Wiring adaptor for other air-conditioner	HDTA103A51	■ To use any of the above optional controllers, an appropriate adaptor must be installed on the product unit to be controlled.
8	DIII-NET Expander adaptor	DTA109A51	■ Up to 1,024 units can be centrally controlled in 64 different groups. ■ Wiring restrictions (max. length : 1,000m, total wiring length : 2,000m, max. number of branches : 16) apply to each adaptor.
9	Mounting plate	KRP4A92	■ Fixing plate for DTA109A51

**Note:**

Installation box for H adaptor must be procured on site.

## Building management system

No.	Part name		Model No.	Function		
1	intelligent Touch Controller	Without PPD	DCS601B51	Air-Conditioning management system that can be controlled by a compact all-in-one unit. PPD: Power Proportional Distribution function • Auto cool/heat change-over • Temperature limitation • Multilingual (English, French, German, Spanish, Italian, or Chinese)		
		With PPD	DCS601B51 DCS002B51			
1-1	Electrical box with earth terminal (4blocks)		KJB411A	Wall embedded switch box.		
2	intelligent Manager ECO 21	Number of units to be connected	128 units	DAM602A52	Air conditioner management system (featuring minimized engineering) that can be controlled by personal computers.	
			192 units	DAM602A53		
			256 units	DAM602A51		
			512 units	DAM602A51x2		
			768 units	DAM602A51x3		
1024 units	DAM602A51x4					
2-1	Communication Line	Optional DIII Ai unit		DAM101A51	Analog input for "sliding temperature" function (to reduce cold shock) for intelligent Manager ECO21.	
3		H1 Interface for use in BACnet®		DMS502A51	Interface unit to allow communications between VRV and BMS. Operation and monitoring of air-conditioning systems through BACnet® communications.	
3-1		Optional DIII board		DAM411A1	Expansion kit, installed on DMS502A51, to provide 3 more DIII-NET communication ports. Not usable independently.	
3-2		Optional Di board		DAM412A1	Expansion kit, installed on DMS502A51, to provide 16 more wattmeter pulse input points. Not usable independently.	
4		H2 Interface for use in LON WORKS®		DMS504B51	Interface unit to allow communications between VRV and BMS. Operation and monitoring of air-conditioning systems through LON WORKS® communication.	
5	Contact/analog signal	Parallel interface	Basic unit		DPF201A51	Enables ON/OFF command, operation and display of malfunction; can be used in combination with up to 4 units.
6			Temperature measurement units		DPF201A52	Enables temperature measurement output for 4 groups; 0-5VDC.
7			Temperature setting units		DPF201A53	Enables temperature setting input for 16 groups; 0-5VDC.
8	Unification adaptor for computerized control		DCS302A52	Interface between the central monitoring board and central control units		
9-1	Wiring adaptor for electrical appendices (1)		KRP2A53, 61, 62	Simultaneously controls air-conditioning control computer and up to 64 groups of indoor units.		
9-2	Wiring adaptor for electrical appendices (2)		KRP4A51-54	To control the group of indoor units collectively, which are connected by the transmission wiring of remote controller.		
13	External control adaptor for outdoor unit (Must be installed on indoor units.)		DTA104A53, 61, 62	Cooling/Heating mode change over. Demand control and Low noise control are available between the plural outdoor units.		

**Note:**

H1. BACnet® is a registered trademark of American Society of Heating, Refrigerating and Air-Conditioning Engineers (ASHRAE).

H2. LON WORKS® is a registered trade mark of Echelon Corporation.

## 4.2 Option Lists (Outdoor Unit)

### RXYQ5 ~ 16MY1B

Optional accessories		RXYQ5MY1B	RXYQ8MY1B RXYQ10MY1B	RXYQ12MY1B RXYQ14MY1B RXYQ16MY1B
Cool/Heat Selector		KRC19-26A		
Cool/Heat Selector	Fixing box	KJB111A		
Distributive Piping	Refnet header	KHRP26M22H, KHRP26M33H (Max. 4 branch) (Max. 8 branch)	KHRP26M22H, KHRP26M33H, (Max. 4 branch) (Max. 8 branch)	KHRP26M22H, KHRP26M33H, KHRP26M72H (Max. 4 branch) (Max. 8 branch)
	Refnet joint	KHRP26M22T	KHRP26M22T, KHRP26M33T,	KHRP26M22T, KHRP26M33T, KHRP26M72T
Kit of air discharge duct		KPF26B160	KPF26B280	KPF26B450
Central drain pan kit		KWC26B160	KWC26B280	KWC26B450
Refrigerant leak detector kit		KFLD26A		

3D039551A

### RXYQ18 ~ 32MY1B

Optional accessories		RXYQ18MY1B RXYQ20MY1B	RXYQ22MY1B RXYQ24MY1B RXYQ26MY1B	RXYQ28MY1B	RXYQ30MY1B RXYQ32MY1B
Cool/Heat Selector		KRC19-26A			
Cool/Heat Selector	Fixing box	KJB111A			
Distributive Piping	Refnet header	KHRP26M22H, KHRP26M33H, KHRP26M72H, KHRP26M73H (Max. 4 branch) (Max. 8 branch) (Max. 8 branch) (Max. 8 branch)			
	Refnet joint	KHRP26M22T, KHRP26M33T, KHRP26M72T, KHRP26M73T			
Outdoor unit multi connection piping kit		BHFP22M90			
Pipe size reducer		KHRP26M73TP, KHRP26M73HP, BHFP22M90P			
Kit of air discharge duct		KPF26B280 × 2	KPF26B280 KPF26B450	KPF26B450 × 2	KPF26B450 × 2
Central drain pan kit		KWC26B280 × 2	KWC26B280 KWC26B450	KWC26B450 × 2	KWC26B450 × 2
Refrigerant leak detector kit		KFLD26A			

3D039552A

### RXYQ34 ~ 48MY1B

Optional accessories		RXYQ34MY1B RXYQ36MY1B	RXYQ38MY1B	RXYQ40MY1B RXYQ42MY1B	RXYQ44MY1B RXYQ46MY1B RXYQ48MY1B
Cool/Heat Selector		KRC19-26A			
Cool/Heat Selector	Fixing box	KJB111A			
Distributive Piping	Refnet header	KHRP26M22H, KHRP26M33H, KHRP26M72H, KHRP26M73H (Max. 4 branch) (Max. 8 branch) (Max. 8 branch) (Max. 8 branch)			
	Refnet joint	KHRP26M22T, KHRP26M33T, KHRP26M72T, KHRP26M73T			
Outdoor unit multi connection piping kit		BHFP22M135			
Pipe size reducer		KHRP26M73TP, KHRP26M73HP, BHFP22M90P			
Kit of air discharge duct		KPF26B280 × 2 KPF26B450	KPF26B280 KPF26B450 × 2	KPF26B280 KPF26B450 × 2	KPF26B450 × 3
Central drain pan kit		KWC26B280 × 2 KWC26B450	KWC26B280 KWC26B450 × 2	KWC26B280 KWC26B450 × 2	KWC26B450 × 3
Refrigerant leak detector kit		KFLD26A			

3D039553A

# 5. Piping Installation Point

## 5.1 Piping Installation Point

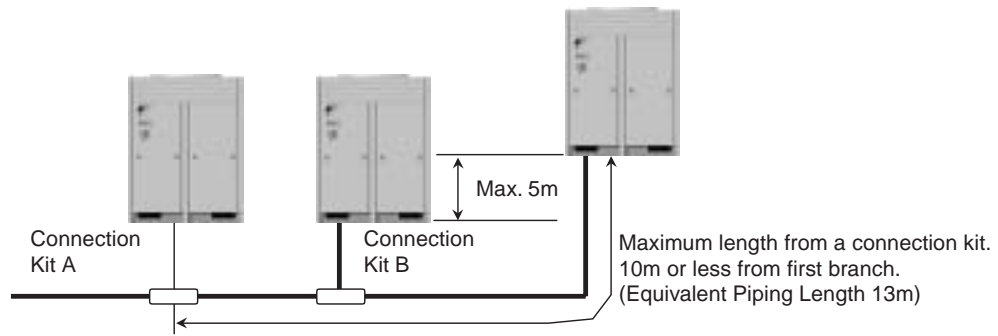

Since there is a possibility that oil may be collected on a stop machine side, install piping between outdoor units to go to level or go up to an outdoor unit, and to make a slope.

(V3084)

The projection part between multi connection piping kits

When the piping length between the multi connection kits or between multi connection kit and outdoor unit is 2m or more, prepare a vertical projection part (200mm or more as shown below) only on the gas pipe line location less than 2m from multi connection kit.

In the case of 2m or less

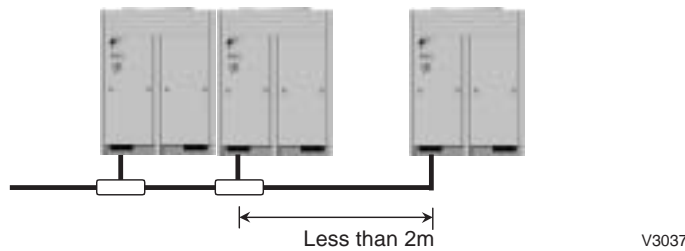

V3037

In the case of 2m or more

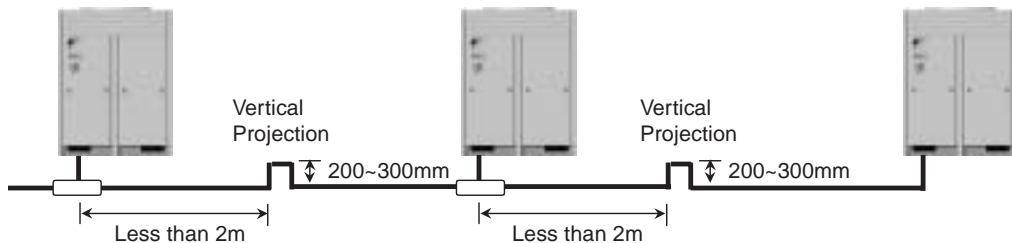
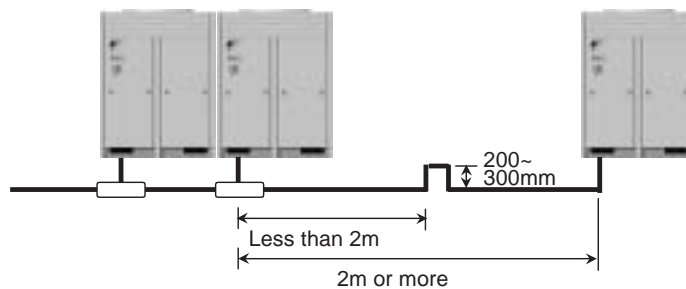

(V3085)

## 5.2 The Example of A Wrong Pattern

Wrong



Oil is collected to the outdoor unit at the time of a stop, because of bottom omission of piping.

V3039

Wrong

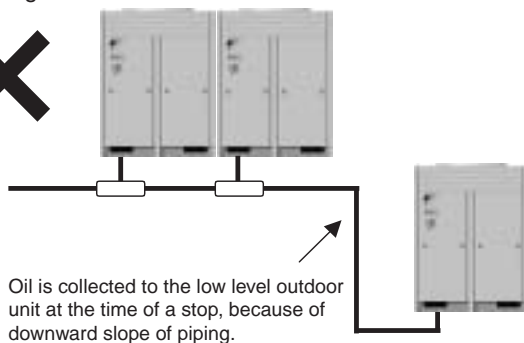

Oil is collected to the low level outdoor unit at the time of a stop, because of downward slope of piping.

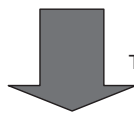

The example of installation on which oil is not collected.

Good

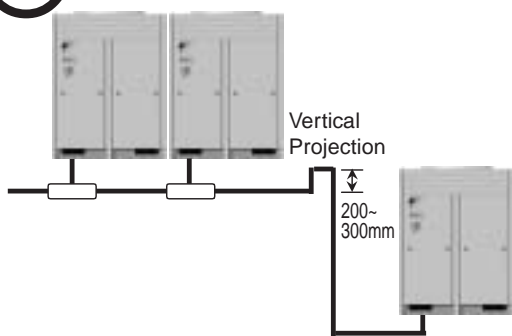

Good

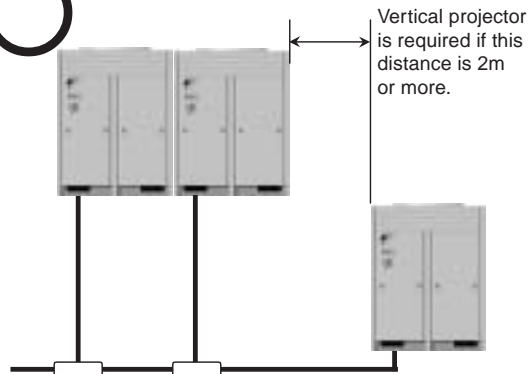

(V3086)

Max. allowable Piping Length	Outdoor Unit - Multi Connection Piping Kit	Actual piping length 10m or less, equivalent length 13m or less
	Multi Connection Piping Kit - Indoor Unit	Actual piping length 150m or less, equivalent length 175m or less, the total extension 300m or less
	REFNET Joint - Indoor Unit	Actual piping length 40m or less
Allowable Level Difference	Outdoor Unit - Outdoor Unit	5m or less
	Outdoor Unit - Indoor Unit	50m or less (when an outdoor unit is lower than indoor units : 40m or less)
	Indoor Unit - Indoor Unit	15m or less

## 6. Selection of Pipe Size, Joints and Header

### 6.1 RXYQ5MY1B, RXYQ8MY1B, RXYQ10MY1B, RXYQ12MY1B, RXYQ14MY1B, RXYQ16MY1B

#### 6.1.1 How to select the REFNET Joint

##### How to select the REFNET Joint

Select the REFNET Joint from the following table when using REFNET Joints at the first branch counted from the outdoor unit side.

(Ex. : REFNET Joint A)

Outdoor Unit	REFNET Joints (Kit Name)
RXYQ5MY1B	KHRP26M22T
RXYQ8,10MY1B	KHRP26M33T
RXYQ12-16MY1B	KHRP26M72T

For REFNET Joints other than the first branch, select the proper ones based on the total capacity index of the indoor units installed after the first branch using the following table :

Total capacity index of indoor units	REFNET Joints (Kit Name)
<200	KHRP26M22T
≥200~<290	KHRP26M33T
≥290	KHRP26M72T

#### 6.1.2 How to select pipe size

##### Between outdoor unit and uppermost stream REFNET Joint.

Pipe size connected to outdoor unit.

Outdoor Unit	Gas	Liquid
RXYQ5MY1B	φ15.9	φ9.5
RXYQ8MY1B	φ19.1	
RXYQ10MY1B	φ22.2	
RXYQ12-16MY1B	φ28.6	φ12.7

##### Piping Material

Select the piping material to be used from the next table according to piping size.

Piping Size (O / D)	Temper grade of Material
φ15.9 or less	O
φ19.1 or more	1 / 2H or H

Wall thickness of refrigerant pipe

(Unit : mm)

Temper grade	O Type				1/2H Type							
	φ6.4	φ9.5	φ12.7	φ15.9	φ19.1	φ22.2	φ25.4	φ28.6	φ31.8	φ34.9	φ38.1	φ41.3
Copper tube O.D												
Copper tube W.T (Minimum requirement)	0.80	0.80	0.80	0.99	0.80	0.80	0.88	0.99	1.10	1.21	1.32	1.43

\*The table shows the requirements of Japanese High Pressure Gas Control law. The thickness and material shall be selected in accordance with local code. (As of Jan.2003)

### 6.1.3 How to select the REFNET header

When connecting the indoor unit larger than 250 or more, use with KHRP26M33T,M72T to upper stream side.

(Do not connect downstream side)

Select the proper REFNET Header using the following table based on the total capacity index of indoor units installed after the header.

Total capacity index of indoor units	REFNET Header (Kit Name)
<200	KHRP26M22H (Max.4 Branches)
<290	KHRP26M33H (Max.8 Branches)
≥290	KHRP26M72H (Max.8 Branches)

### 6.1.4 Piping between the REFNET Joints

Select the proper pipe size using the following table based on the total capacity index of indoor units connected downstream.

Connection piping size should not exceed the refrigerant piping size selected by "the model with combination units".

Total capacity index of indoor units	Gas	Liquid
<200	φ15.9	φ9.5
≥200~<290	φ22.2	
≥290~<420	φ28.6	φ12.7
≥420	φ28.6	φ15.9

### 6.1.5 Piping between the REFNET Joints and indoor unit

Pipe size for direct connection to indoor unit must be the same as the connection size of indoor unit.

Connection pipe size of indoor unit.

Indoor Units	Gas	Liquid
20 · 25 · 32 · 40 · 50 Type	φ12.7	φ9.5
63 · 80 · 100 · 125 Type	φ15.9	
200 Type	φ19.1	
250 Type	φ22.2	

## 6.2 RXYQ18MY1B, RXYQ20MY1B, RXYQ22MY1B, RXYQ24MY1B, RXYQ26MY1B, RXYQ28MY1B, RXYQ30MY1B, RXYQ32MY1B, RXYQ34MY1B, RXYQ36MY1B, RXYQ38MY1B, RXYQ40MY1B, RXYQ42MY1B, RXYQ44MY1B, RXYQ46MY1B, RXYQ48MY1B

### 6.2.1 How to select the REFNET Joint

#### How to select the REFNET Joint

Select the REFNET Joint from the following table. When using REFNET Joints at the first branch counted from the outdoor unit side.

(Ex. : REFNET Joint A)

Outdoor Unit	REFNET Joint (Kit Name)
RXYQ18MY1B-22MY1B	KHRP26M72T
RXYQ24MY1B-48MY1B	KHRP26M73T

For REFNET Joints other than the first branch, select the proper ones based on the total capacity index of the indoor units installed after the first branch using the following table :

Total capacity index of indoor units	REFNET Joints (Kit Name)
<200	KHRP26M22T
≥200~<290	KHRP26M33T
≥290	KHRP26M72T
≥640	KHRP26M73T

### 6.2.2 How to select pipe size

#### Main Piping (Between Multi connection piping kit and REFNET Joint)

Select the proper ones based on the following table :

Outdoor Unit	Gas	Liquid
RXYQ18MY1B	φ28.6	φ15.9
RXYQ20MY1B		
RXYQ22MY1B		
RXYQ24MY1B	φ34.9	φ19.1
RXYQ26MY1B		
RXYQ28MY1B		
RXYQ30MY1B		
RXYQ32MY1B		
RXYQ34MY1B	φ41.3	φ19.1
RXYQ36MY1B		
RXYQ38MY1B		
RXYQ40MY1B		
RXYQ42MY1B		
RXYQ44MY1B		
RXYQ46MY1B		
RXYQ48MY1B		

#### Piping Material

Select the piping material to be used from the next table according to piping size.

Piping Size (O / D)	Temper grade of Material
φ15.9 or less	O
φ19.1 or more	1 / 2H or H

\* O: Soft (Annealed)

\* H: Hard (Drawn)

Wall thickness of refrigerant pipe

(Unit : mm)

Temper grade	O Type				1/2H Type							
	φ6.4	φ9.5	φ12.7	φ15.9	φ19.1	φ22.2	φ25.4	φ28.6	φ31.8	φ34.9	φ38.1	φ41.3
Copper tube O.D												
Copper tube W.T (Minimum requirement)	0.80	0.80	0.80	0.99	0.80	0.80	0.88	0.99	1.10	1.21	1.32	1.43

\*The table shows the requirements of Japanese High Pressure Gas Control law. The thickness and material shall be selected in accordance with local code. (As of Jan.2003)

### 6.2.3 How to select the REFNET header

Select the proper REFNET Header using the following table based on the total capacity index of indoor units installed after the header.

Total capacity index of indoor units	REFNET Header (Kit Name)
<200	KHRP26M22H (Max.4 Branches)
	KHRP26M33H (Max8 Branches)
≥200~<290	KHRP26M72H (Max8 Branches)
≥290~<640	KHRP26M73H (Max8 Branches) KHRP26M73HP

When using REFNET Joints at the first branch counted from the outdoor unit side, use KHRP26M73H for larger than RXYQ24MY1B.

### 6.2.4 Piping between the REFNET Joints.

Select the proper pipe size using the following table based on the total capacity index of indoor units connected downstream.

Connection piping size should be larger than main piping size.

Connection piping size should not exceed the refrigerant piping size selected by "the model with combination units".

Total capacity index of indoor units	Gas	Liquid
<200	φ15.9	φ9.5
≥200~<290	φ22.2	
≥290~<420	φ28.6	φ12.7
≥420~<640		φ15.9
≥640~<920	φ34.9	φ19.1
≥920	φ41.3	

### 6.2.5 Piping between the multi connection piping kit

Select the proper pipe size using the following table based on the total capacity index of outdoor units connected upper stream.

Total capacity index of outdoor units connected to upper stream	Gas	Liquid	Oil
Less than RXYQ22MY1B	φ28.6	φ15.9	φ6.4
RXYQ24MY1B	φ34.9		
RXYQ26MY1B or more~ Less than RXYQ32MY1B		φ19.1	



## 6.2.6 Outdoor Unit Multi Connection Piping Kit

Select the piping kit according to the No. of outdoor units

No. of outdoor units	Multi Connection Piping Kit
2 units	BHFP22M90 BHFP22M90P
3 units	BHFP22M135 BHFP22M135P

## 6.2.7 Piping between REFNET Joint and Indoor Unit

Pipe size for direct connection to indoor unit must be the same as the connection size of indoor unit.

Connection pipe size of indoor unit.

Indoor Units	Gas	Liquid
20 · 25 · 32 · 40 · 50 Type	φ12.7	φ6.4
63 · 80 · 100 · 125 Type	φ15.9	φ9.5
200 Type	φ19.1	
250 Type	φ22.2	

## 6.2.8 Piping between outdoor Unit and Multi Connection Piping Kit

Pipe size for direct connection to outdoor unit must be the same as the connection size of outdoor unit.

Outdoor Units	Gas	Liquid	Oil
RXYQ8MY1B	φ19.1	φ9.5	φ6.4
RXYQ10MY1B	φ22.2		
RXYQ12-16MY1B	φ28.6	φ12.7	

## 7. Thermistor Resistance / Temperature Characteristics

Indoor unit	For air suction	R1T
	For liquid pipe	R2T
	For gas pipe	R3T
Outdoor unit	For outdoor air	R1T
	For coil	R2T
	For suction pipe	R4T
	For Receiver gas pipe	R5T

			(kΩ)		
T°C	0.0	0.5	T°C	0.0	0.5
-20	197.81	192.08	30	16.10	15.76
-19	186.53	181.16	31	15.43	15.10
-18	175.97	170.94	32	14.79	14.48
-17	166.07	161.36	33	14.18	13.88
-16	156.80	152.38	34	13.59	13.31
-15	148.10	143.96	35	13.04	12.77
-14	139.94	136.05	36	12.51	12.25
-13	132.28	128.63	37	12.01	11.76
-12	125.09	121.66	38	11.52	11.29
-11	118.34	115.12	39	11.06	10.84
-10	111.99	108.96	40	10.63	10.41
-9	106.03	103.18	41	10.21	10.00
-8	100.41	97.73	42	9.81	9.61
-7	95.14	92.61	43	9.42	9.24
-6	90.17	87.79	44	9.06	8.88
-5	85.49	83.25	45	8.71	8.54
-4	81.08	78.97	46	8.37	8.21
-3	76.93	74.94	47	8.05	7.90
-2	73.01	71.14	48	7.75	7.60
-1	69.32	67.56	49	7.46	7.31
0	65.84	64.17	50	7.18	7.04
1	62.54	60.96	51	6.91	6.78
2	59.43	57.94	52	6.65	6.53
3	56.49	55.08	53	6.41	6.53
4	53.71	52.38	54	6.65	6.53
5	51.09	49.83	55	6.41	6.53
6	48.61	47.42	56	6.18	6.06
7	46.26	45.14	57	5.95	5.84
8	44.05	42.98	58	5.74	5.43
9	41.95	40.94	59	5.14	5.05
10	39.96	39.01	60	4.96	4.87
11	38.08	37.18	61	4.79	4.70
12	36.30	35.45	62	4.62	4.54
13	34.62	33.81	63	4.46	4.38
14	33.02	32.25	64	4.30	4.23
15	31.50	30.77	65	4.16	4.08
16	30.06	29.37	66	4.01	3.94
17	28.70	28.05	67	3.88	3.81
18	27.41	26.78	68	3.75	3.68
19	26.18	25.59	69	3.62	3.56
20	25.01	24.45	70	3.50	3.44
21	23.91	23.37	71	3.38	3.32
22	22.85	22.35	72	3.27	3.21
23	21.85	21.37	73	3.16	3.11
24	20.90	20.45	74	3.06	3.01
25	20.00	19.56	75	2.96	2.91
26	19.14	18.73	76	2.86	2.82
27	18.32	17.93	77	2.77	2.72
28	17.54	17.17	78	2.68	2.64
29	16.80	16.45	79	2.60	2.55
30	16.10	15.76	80	2.51	2.47

**Outdoor Unit  
Thermistors for  
Discharge Pipe  
(R3T)**

						(kΩ)		
T°C	0.0	0.5	T°C	0.0	0.5	T°C	0.0	0.5
0	640.44	624.65	50	72.32	70.96	100	13.35	13.15
1	609.31	594.43	51	69.64	68.34	101	12.95	12.76
2	579.96	565.78	52	67.06	65.82	102	12.57	12.38
3	552.00	538.63	53	64.60	63.41	103	12.20	12.01
4	525.63	512.97	54	62.24	61.09	104	11.84	11.66
5	500.66	488.67	55	59.97	58.87	105	11.49	11.32
6	477.01	465.65	56	57.80	56.75	106	11.15	10.99
7	454.60	443.84	57	55.72	54.70	107	10.83	10.67
8	433.37	423.17	58	53.72	52.84	108	10.52	10.36
9	413.24	403.57	59	51.98	50.96	109	10.21	10.06
10	394.16	384.98	60	49.96	49.06	110	9.92	9.78
11	376.05	367.35	61	48.19	47.33	111	9.64	9.50
12	358.88	350.62	62	46.49	45.67	112	9.36	9.23
13	342.58	334.74	63	44.86	44.07	113	9.10	8.97
14	327.10	319.66	64	43.30	42.54	114	8.84	8.71
15	312.41	305.33	65	41.79	41.06	115	8.59	8.47
16	298.45	291.73	66	40.35	39.65	116	8.35	8.23
17	285.18	278.80	67	38.96	38.29	117	8.12	8.01
18	272.58	266.51	68	37.63	36.98	118	7.89	7.78
19	260.60	254.72	69	36.34	35.72	119	7.68	7.57
20	249.00	243.61	70	35.11	34.51	120	7.47	7.36
21	238.36	233.14	71	33.92	33.35	121	7.26	7.16
22	228.05	223.08	72	32.78	32.23	122	7.06	6.97
23	218.24	213.51	73	31.69	31.15	123	6.87	6.78
24	208.90	204.39	74	30.63	30.12	124	6.69	6.59
25	200.00	195.71	75	29.61	29.12	125	6.51	6.42
26	191.53	187.44	76	28.64	28.16	126	6.33	6.25
27	183.46	179.57	77	27.69	27.24	127	6.16	6.08
28	175.77	172.06	78	26.79	26.35	128	6.00	5.92
29	168.44	164.90	79	25.91	25.49	129	5.84	5.76
30	161.45	158.08	80	25.07	24.66	130	5.69	5.61
31	154.79	151.57	81	24.26	23.87	131	5.54	5.46
32	148.43	145.37	82	23.48	23.10	132	5.39	5.32
33	142.37	139.44	83	22.73	22.36	133	5.25	5.18
34	136.59	133.79	84	22.01	21.65	134	5.12	5.05
35	131.06	128.39	85	21.31	20.97	135	4.98	4.92
36	125.79	123.24	86	20.63	20.31	136	4.86	4.79
37	120.76	118.32	87	19.98	19.67	137	4.73	4.67
38	115.95	113.62	88	19.36	19.05	138	4.61	4.55
39	111.35	109.13	89	18.75	18.46	139	4.49	4.44
40	106.96	104.84	90	18.17	17.89	140	4.38	4.32
41	102.76	100.73	91	17.61	17.34	141	4.27	4.22
42	98.75	96.81	92	17.07	16.80	142	4.16	4.11
43	94.92	93.06	93	16.54	16.29	143	4.06	4.01
44	91.25	89.47	94	16.04	15.79	144	3.96	3.91
45	87.74	86.04	95	15.55	15.31	145	3.86	3.81
46	84.38	82.75	96	15.08	14.85	146	3.76	3.72
47	81.16	79.61	97	14.62	14.40	147	3.67	3.62
48	78.09	76.60	98	14.18	13.97	148	3.58	3.54
49	75.14	73.71	99	13.76	13.55	149	3.49	3.45
50	72.32	70.96	100	13.35	13.15	150	3.41	3.37

## 8. Pressure Sensor

$P_H = 1.38V - 0.69$   
 $P_L = 0.57V - 0.28$   
 $P_H$  : High pressure (MPa)  
 $V_L$  : Low pressure (MPa)  
 $V$  : Voltage (V)

$P_H$  : Detected Pressure [High Side] MPa  
 $P_L$  : Detected Pressure [Low Side] MPa  
 $V_H$  : Output Voltage [High Side]  $V_{DC}$   
 $V_L$  : Output Voltage [Low Side]  $V_{DC}$

Detected Pressure

$P_H$   $P_L$   
 (kg/cm<sup>2</sup>) MPa

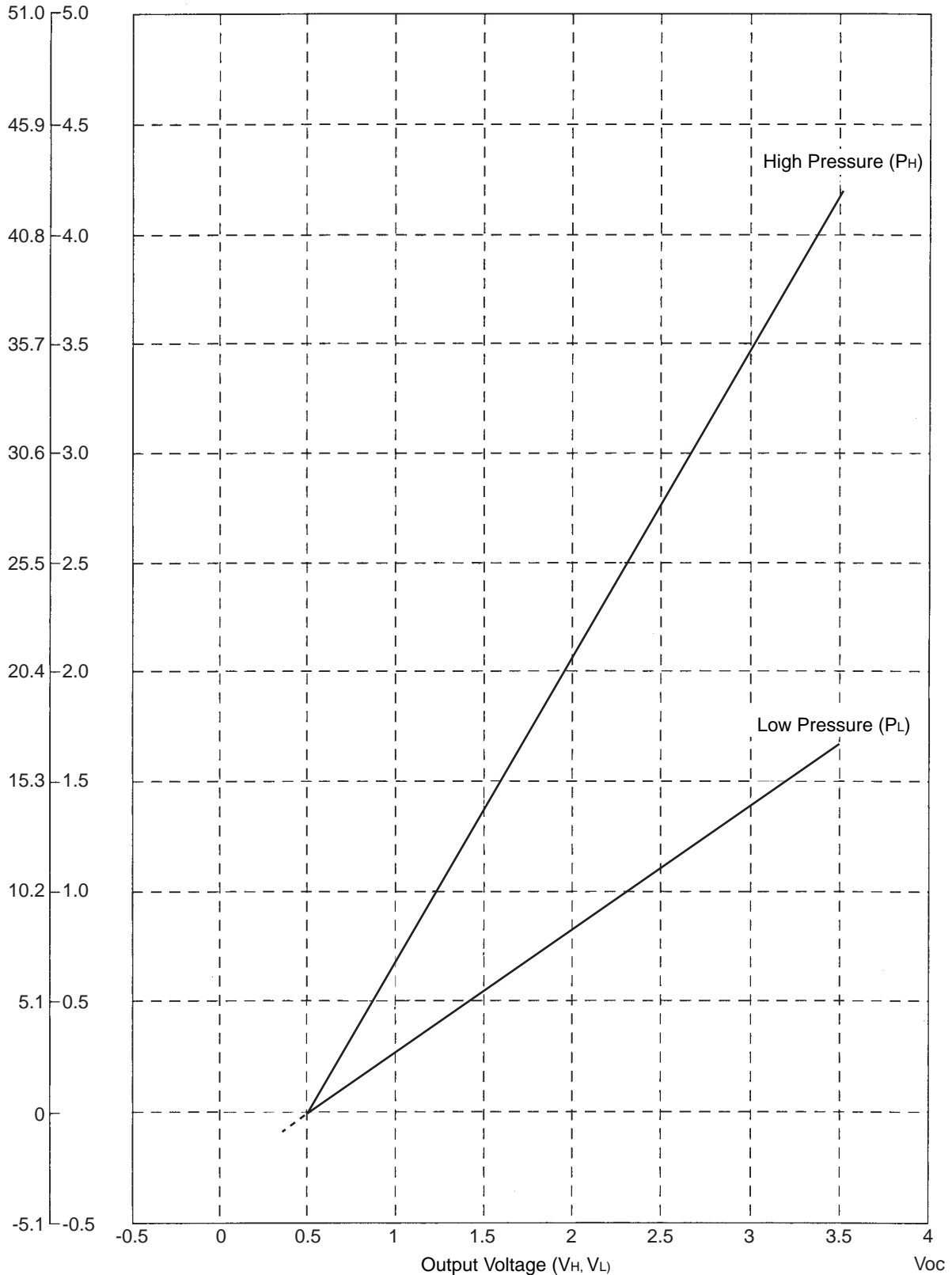

(V3053)

# 9. Method of Replacing The Inverter's Power Transistors and Diode Modules

## 9.1 Method of Replacing The Inverter's Power Transistors and Diode Modules

Inverter P.C.Board

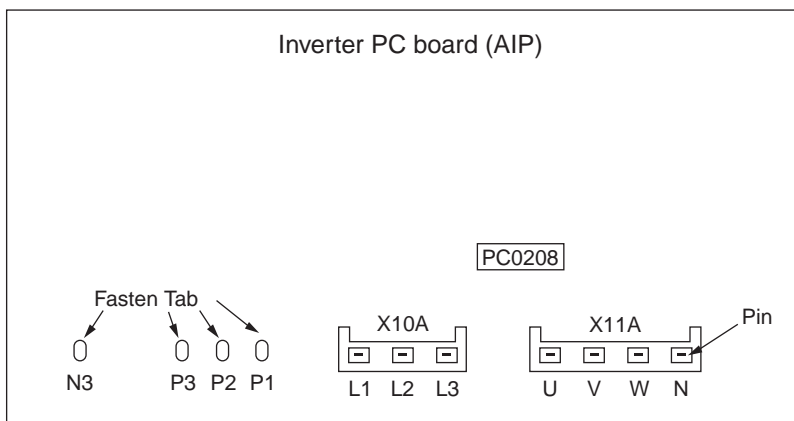

Electronic circuit

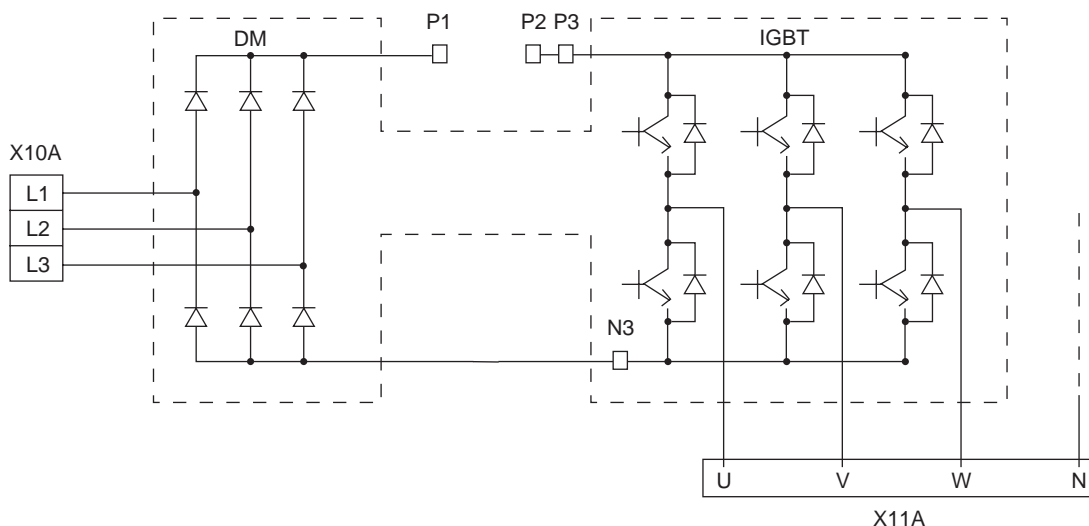

(V2895)

[Decision according to continuity check by analog tester]

- Before checking, disconnect the electric wiring connected to the power transistor and diode module.

### Power Transistor IGBT (On Inverter PC Board)

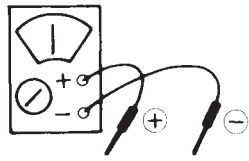

P3	-	U	Continuity	} ✘
"	-	V	"	
"	-	W	"	
"	-	N	(Approx. 100kΩ)	
U	-	P3	Approx. 4kΩ → ∞	
V	-	"	"	
W	-	"	"	
N	-	"	(Approx. 160kΩ)	

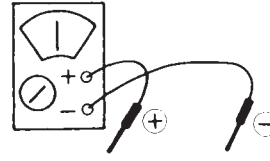

N3	-	U	Approx. 4kΩ → ∞	} ✘
"	-	V	"	
"	-	W	"	
"	-	N	(Approx. 250kΩ)	
U	-	N3	Continuity	
V	-	"	"	
W	-	"	"	
N	-	"	(Approx. 100kΩ)	

\* In the case of continuity, the resistance must be the same for all phases.

(V2896)

#### (Decision)

If other than given above, the power unit is defective and must be replaced.



**Note:** If using a digital tester, ∞ and continuity may be reversed.

### Diode Module

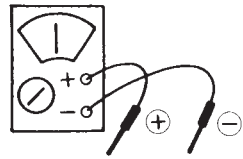

P1	-	L1	Continuity
P1	-	L2	"
P1	-	L3	"
L1	-	P1	∞
L2	-	P1	∞
L3	-	P1	∞

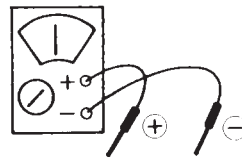

N3	-	L1	∞
"	-	L2	∞
"	-	L3	∞
L1	-	N3	Continuity
L2	-	"	"
L3	-	"	"

(V2897)

#### (Decision)

If other than given above, the diode module is defective and must be replaced.



**Note:** If using a digital tester, ∞ and continuity may be reversed.



# Part 9 Precautions for New Refrigerant (R410)

1. Precautions for New Refrigerant (R410) .....	318
1.1 Outline .....	318
1.2 Refrigerant Cylinders.....	320
1.3 Service Tools.....	321



# 1. Precautions for New Refrigerant (R410)

## 1.1 Outline

### 1.1.1 About Refrigerant R410A

- Characteristics of new refrigerant, R410A
  1. Performance  
Almost the same performance as R22 and R407C
  2. Pressure  
Working pressure is approx. 1.4 times more than R22 and R407C.
  3. Refrigerant composition  
Few problems in composition control, since it is a Quasi-azeotropic mixture refrigerant.

	HFC units (Units using new refrigerants)		HCFC units
Refrigerant name	R407C	R410A	R22
Composing substances	Non-azeotropic mixture of HFC32, HFC125 and HFC134a (*1)	Quasi-azeotropic mixture of HFC32 and JFC125 (*1)	Single-component refrigerant
Design pressure	3.2 MPa (gauge pressure) = 32.6 kgf/cm <sup>2</sup>	3.80 MPa (gauge pressure) = 38.7 kgf/cm <sup>2</sup>	2.75MPa (gauge pressure) = 28.0 kgf/cm <sup>2</sup>
Refrigerant oil	Synthetic oil (Ether)		Mineral oil (Suniso)
Ozone destruction factor (ODP)	0	0	0.05
Combustibility	None	None	None
Toxicity	None	None	None

- H1. Non-azeotropic mixture refrigerant: mixture of two or more refrigerants having different boiling points.
- H2. Quasi-azeotropic mixture refrigerant: mixture of two or more refrigerants having similar boiling points.
- H3. The design pressure is different at each product. Please refer to the installation manual for each product.  
(Reference) 1 MPa ≙ 10.19716 kgf / cm<sup>2</sup>

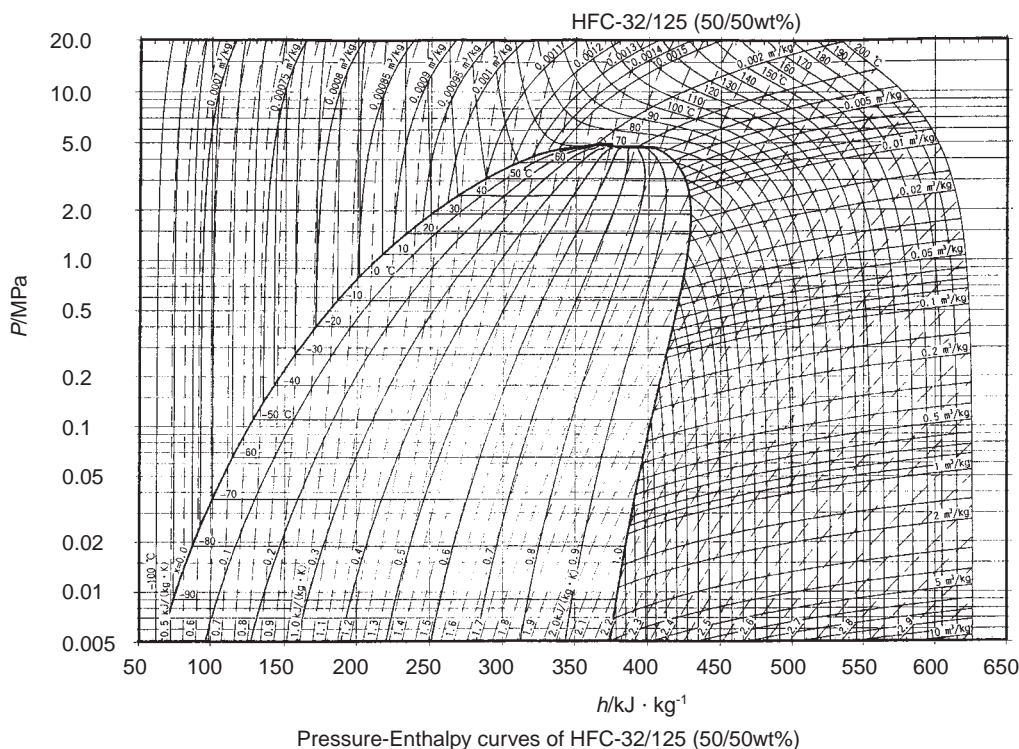

■ Thermodynamic characteristic of R410A

DAIREP ver2.0

Temperature (°C)	Steam pressure (kPa)		Density (kg/m <sup>3</sup> )		Specific heat at constant pressure (kJ/kgK)		Specific enthalpy (kJ/kg)		Specific entropy (kJ/KgK)	
	Liquid	Vapor	Liquid	Vapor	Liquid	Vapor	Liquid	Vapor	Liquid	Vapor
-70	36.13	36.11	1410.7	1.582	1.372	0.695	100.8	390.6	0.649	2.074
-68	40.83	40.80	1404.7	1.774	1.374	0.700	103.6	391.8	0.663	2.066
-66	46.02	45.98	1398.6	1.984	1.375	0.705	106.3	393.0	0.676	2.058
-64	51.73	51.68	1392.5	2.213	1.377	0.710	109.1	394.1	0.689	2.051
-62	58.00	57.94	1386.4	2.463	1.378	0.715	111.9	395.3	0.702	2.044
-60	64.87	64.80	1380.2	2.734	1.379	0.720	114.6	396.4	0.715	2.037
-58	72.38	72.29	1374.0	3.303	1.380	0.726	117.4	397.6	0.728	2.030
-56	80.57	80.46	1367.8	3.350	1.382	0.732	120.1	398.7	0.741	2.023
-54	89.49	89.36	1361.6	3.696	1.384	0.737	122.9	399.8	0.754	2.017
-52	99.18	99.03	1355.3	4.071	1.386	0.744	125.7	400.9	0.766	2.010
-51.58	101.32	101.17	1354.0	4.153	1.386	0.745	126.3	401.1	0.769	2.009
-50	109.69	109.51	1349.0	4.474	1.388	0.750	128.5	402.0	0.779	2.004
-48	121.07	120.85	1342.7	4.909	1.391	0.756	131.2	403.1	0.791	1.998
-46	133.36	133.11	1336.3	5.377	1.394	0.763	134.0	404.1	0.803	1.992
-44	146.61	146.32	1330.0	5.880	1.397	0.770	136.8	405.2	0.816	1.987
-42	160.89	160.55	1323.5	6.419	1.401	0.777	139.6	406.2	0.828	1.981
-40	176.24	175.85	1317.0	6.996	1.405	0.785	142.4	407.3	0.840	1.976
-38	192.71	192.27	1310.5	7.614	1.409	0.792	145.3	408.3	0.852	1.970
-36	210.37	209.86	1304.0	8.275	1.414	0.800	148.1	409.3	0.863	1.965
-34	229.26	228.69	1297.3	8.980	1.419	0.809	150.9	410.2	0.875	1.960
-32	249.46	248.81	1290.6	9.732	1.424	0.817	153.8	411.2	0.887	1.955
-30	271.01	270.28	1383.9	10.53	1.430	0.826	156.6	412.1	0.899	1.950
-28	293.99	293.16	1277.1	11.39	1.436	0.835	159.5	413.1	0.911	1.946
-26	318.44	317.52	1270.2	12.29	1.442	0.844	162.4	414.0	0.922	1.941
-24	344.44	343.41	1263.3	13.26	1.448	0.854	165.3	414.9	0.934	1.936
-22	372.05	370.90	1256.3	14.28	1.455	0.864	168.2	415.7	0.945	1.932
-20	401.34	400.06	1249.2	15.37	1.461	0.875	171.1	416.6	0.957	1.927
-18	432.36	430.95	1242.0	16.52	1.468	0.886	174.1	417.4	0.968	1.923
-16	465.20	463.64	1234.8	17.74	1.476	0.897	177.0	418.2	0.980	1.919
-14	499.91	498.20	1227.5	19.04	1.483	0.909	180.0	419.0	0.991	1.914
-12	536.58	534.69	1220.0	20.41	1.491	0.921	182.9	419.8	1.003	1.910
-10	575.26	573.20	1212.5	21.86	1.499	0.933	185.9	420.5	1.014	1.906
-8	616.03	613.78	1204.9	23.39	1.507	0.947	189.0	421.2	1.025	1.902
-6	658.97	656.52	1197.2	25.01	1.516	0.960	192.0	421.9	1.036	1.898
-4	704.15	701.49	1189.4	26.72	1.524	0.975	195.0	422.6	1.048	1.894
-2	751.64	748.76	1181.4	28.53	1.533	0.990	198.1	423.2	1.059	1.890
0	801.52	798.41	1173.4	30.44	1.543	1.005	201.2	423.8	1.070	1.886
2	853.87	850.52	1165.3	32.46	1.552	1.022	204.3	424.4	1.081	1.882
4	908.77	905.16	1157.0	34.59	1.563	1.039	207.4	424.9	1.092	1.878
6	966.29	962.42	1148.6	36.83	1.573	1.057	210.5	425.5	1.103	1.874
8	1026.5	1022.4	1140.0	39.21	1.584	1.076	213.7	425.9	1.114	1.870
10	1089.5	1085.1	1131.3	41.71	1.596	1.096	216.8	426.4	1.125	1.866
12	1155.4	1150.7	1122.5	44.35	1.608	1.117	220.0	426.8	1.136	1.862
14	1224.3	1219.2	1113.5	47.14	1.621	1.139	223.2	427.2	1.147	1.859
16	1296.2	1290.8	1104.4	50.05	1.635	1.163	226.5	427.5	1.158	1.855
18	1371.2	1365.5	1095.1	53.20	1.650	1.188	229.7	427.8	1.169	1.851
20	1449.4	1443.4	1085.6	56.48	1.666	1.215	233.0	428.1	1.180	1.847
22	1530.9	1524.6	1075.9	59.96	1.683	1.243	236.4	428.3	1.191	1.843
24	1615.8	1609.2	1066.0	63.63	1.701	1.273	239.7	428.4	1.202	1.839
26	1704.2	1697.2	1055.9	67.51	1.721	1.306	243.1	428.6	1.214	1.834
28	1796.2	1788.9	1045.5	71.62	1.743	1.341	246.5	428.6	1.225	1.830
30	1891.9	1884.2	1034.9	75.97	1.767	1.379	249.9	428.6	1.236	1.826
32	1991.3	1983.2	1024.1	80.58	1.793	1.420	253.4	428.6	1.247	1.822
34	2094.5	2086.2	1012.9	85.48	1.822	1.465	256.9	428.4	1.258	1.817
36	2201.7	2193.1	1001.4	90.68	1.855	1.514	260.5	428.3	1.269	1.813
38	2313.0	2304.0	989.5	96.22	1.891	1.569	264.1	428.0	1.281	1.808
40	2428.4	2419.2	977.3	102.1	1.932	1.629	267.8	427.7	1.292	1.803
42	2548.1	2538.6	964.6	108.4	1.979	1.696	271.5	427.2	1.303	1.798
44	2672.2	2662.4	951.4	115.2	2.033	1.771	275.3	426.7	1.315	1.793
46	2800.7	2790.7	937.7	122.4	2.095	1.857	279.2	426.1	1.327	1.788
48	2933.7	2923.6	923.3	130.2	2.168	1.955	283.2	425.4	1.339	1.782
50	3071.5	3061.2	908.2	138.6	2.256	2.069	287.3	424.5	1.351	1.776
52	3214.0	3203.6	892.2	147.7	2.362	2.203	291.5	423.5	1.363	1.770
54	3361.4	3351.0	875.1	157.6	2.493	2.363	295.8	422.4	1.376	1.764
56	3513.8	3503.5	856.8	168.4	2.661	2.557	300.3	421.0	1.389	1.757
58	3671.3	3661.2	836.9	180.4	2.883	2.799	305.0	419.4	1.403	1.749
60	3834.1	3824.2	814.9	193.7	3.191	3.106	310.0	417.6	1.417	1.741
62	4002.1	3992.7	790.1	208.6	3.650	3.511	315.3	415.5	1.433	1.732
64	4175.7	4166.8	761.0	225.6	4.415	4.064	321.2	413.0	1.450	1.722

## 1.2 Refrigerant Cylinders

- Cylinder specifications
  - The cylinder is painted refrigerant color (pink).
  - The cylinder valve is equipped with a siphon tube.

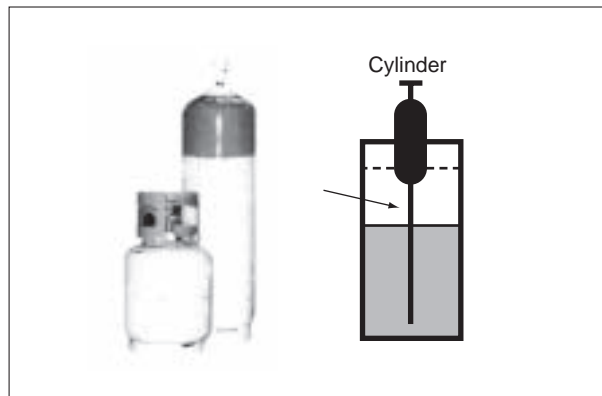

Refrigerant can be charged in liquid state with cylinder in upright position.

Caution: Do not lay cylinder on its side during charging, since it cause refrigerant in gas state to enter the system.

- Handling of cylinders
  - (1) Laws and regulations

R410A is liquefied gas, and the High-Pressure Gas Safety Law must be observed in handling them. Before using, refer to the High-Pressure Gas Safety Law. The Law stipulates standards and regulations that must be followed to prevent accidents with high-pressure gases. Be sure to follow the regulations.
  - (2) Handling of vessels

Since R410A is high-pressure gas, it is contained in high-pressure vessels. Although those vessels are durable and strong, careless handling can cause damage that can lead to unexpected accidents. Do not drop vessels, let them fall, apply impact or roll them on the ground.
  - (3) Storage

Although R410A is not flammable, it must be stored in a well-ventilated, cool, and dark place in the same way as any other high-pressure gases. It should also be noted that high-pressure vessels are equipped with safety devices that releases gas when the ambient temperature reaches more than a certain level (fusible plug melts) and when the pressure exceeds a certain level (spring-type safety valve operates).

## 1.3 Service Tools

R410A is used under higher working pressure, compared to previous refrigerants (R22,R407C). Furthermore, the refrigerating machine oil has been changed from Suniso oil to Ether oil, and if oil mixing is occurred, sludge results in the refrigerants and causes other problems. Therefore, gauge manifolds and charge hoses that are used with a previous refrigerant (R22,R407C) can not be used for products that use new refrigerants.

Be sure to use dedicated tools and devices.

### ■ Tool compatibility

Tool	Compatibility			Reasons for change
	HFC		HCFC	
	R410A	R407C	R22	
Gauge manifold Charge hose	5			<ul style="list-style-type: none"> <li>Do not use the same tools for R22 and R410A.</li> <li>Thread specification differs for R410A and R407C.</li> </ul>
Charging cylinder	5		0	<ul style="list-style-type: none"> <li>Weighting instrument used for HFCs.</li> </ul>
Gas detector		0	5	<ul style="list-style-type: none"> <li>The same tool can be used for HFCs.</li> </ul>
Vacuum pump (pump with reverse flow preventive function)		0		<ul style="list-style-type: none"> <li>To use existing pump for HFCs, vacuum pump adaptor must be installed.</li> </ul>
Weighting instrument		0		
Charge mouthpiece	5			<ul style="list-style-type: none"> <li>Seal material is different between R22 and HFCs.</li> <li>Thread specification is different between R410A and others.</li> </ul>
Flaring tool (Clutch type)		0		<ul style="list-style-type: none"> <li>For R410A, flare gauge is necessary.</li> </ul>
Torque wrench		0		<ul style="list-style-type: none"> <li>Torque-up for 1/2 and 5/8</li> </ul>
Pipe cutter		0		
Pipe expander		0		
Pipe bender		0		
Pipe assembling oil	5			<ul style="list-style-type: none"> <li>Due to refrigerating machine oil change. (No Suniso oil can be used.)</li> </ul>
Refrigerant recovery device	Check your recovery device.			
Refrigerant piping	See the chart below.			<ul style="list-style-type: none"> <li>Only <math>\phi 19.1</math> is changed to 1/2H material while the previous material is "O".</li> </ul>

As for the charge mouthpiece and packing, 1/2UNF20 is necessary for mouthpiece size of charge hose.

### ■ Copper tube material and thickness

Pipe size	Ve-up		Ve-upII	
	R407C		R410A	
	Material	Thickness [mm]	Material	Thickness [mm]
$\phi 6.4$	O	0.8	O	0.8
$\phi 9.5$	O	0.8	O	0.8
$\phi 12.7$	O	0.8	O	0.8
$\phi 15.9$	O	1.0	O	1.0
$\phi 19.1$	O	1.0	1/2H	1.0
$\phi 22.2$	1/2H	1.0	1/2H	1.0
$\phi 25.4$	1/2H	1.0	1/2H	1.0
$\phi 28.6$	1/2H	1.0	1/2H	1.0
$\phi 31.8$	1/2H	1.2	1/2H	1.1
$\phi 38.1$	1/2H	1.4	1/2H	1.4
$\phi 44.5$	1/2H	1.6	1/2H	1.6

\* O: Soft (Annealed)

H: Hard (Drawn)

1. Flaring tool



Flare gauge

■ Specifications

- Dimension A

Unit: mm

Nominal size	Tube O.D. Do	$A^{+0}_{-0.4}$	
		Class-2 (R410A)	Class-1 (Conventional)
1/4	6.35	9.1	9.0
3/8	9.52	13.2	13.0
1/2	12.70	16.6	16.2
5/8	15.88	19.7	19.4
3/4	19.05	24.0	23.3

■ Differences

- Change of dimension A

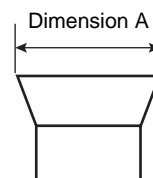

For class-1: R407C  
For class-2: R410A

Conventional flaring tools can be used when the work process is changed.

(change of work process)

Previously, a pipe extension margin of 0 to 0.5mm was provided for flaring. For R410A air conditioners, perform pipe flaring with a pipe extension margin of 1.0 to 1.5mm.

(For clutch type only)

Conventional tool with pipe extension margin adjustment can be used.

## 2. Torque wrench



### ■ Specifications

- Dimension B

Unit:mm

Nominal size	Class-1	Class-2	Previous
1/2	24	26	24
5/8	27	29	27

No change in tightening torque

No change in pipes of other sizes

### ■ Differences

- Change of dimension B  
Only 1/2", 5/8" are extended

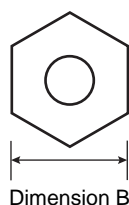

For class-1: R407C  
For class-2: R410A

## 3. Vacuum pump with check valve

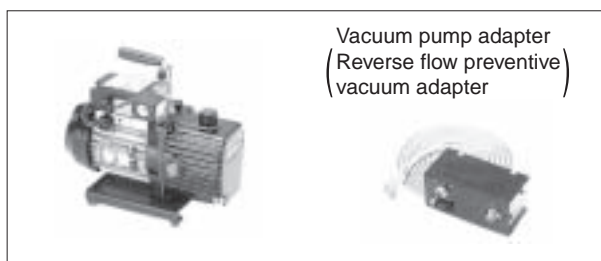

Vacuum pump adapter  
(Reverse flow preventive)  
vacuum adapter

### ■ Specifications

- Discharge speed
  - 50 l/min (50Hz)
  - 60 l/min (60Hz)
- Suction port UNF7/16-20(1/4 Flare)  
UNF1/2-20(5/16 Flare) with adapter
- Maximum degree of vacuum  
-100.7 kpa ( 5 torr – 755 mmHg)

### ■ Differences

- Equipped with function to prevent reverse oil flow
- Previous vacuum pump can be used by installing adapter.

#### 4. Leak tester



- Specifications
  - Hydrogen detecting type, etc.
  - Applicable refrigerants  
R410A, R407C, R404A, R507A, R134a, etc.
- Differences
  - Previous testers detected chlorine. Since HFCs do not contain chlorine, new tester detects hydrogen.

#### 5. Refrigerant oil (Air compal)



- Specifications
  - Contains synthetic oil, therefore it can be used for piping work of every refrigerant cycle.
  - Offers high rust resistance and stability over long period of time.
- Differences
  - Can be used for R410A and R22 units.

#### 6. Gauge manifold for R410A

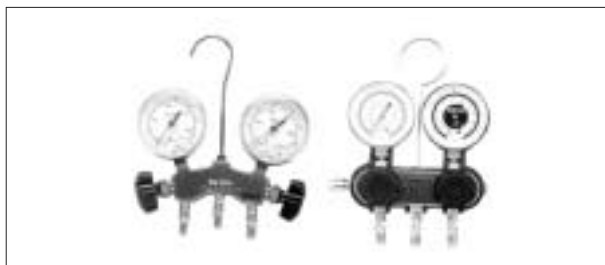

- Specifications
  - High pressure gauge  
- 0.1 to 5.3 MPa (-76 cmHg to 53 kg/cm<sup>2</sup>)
  - Low pressure gauge  
- 0.1 to 3.8 MPa (-76 cmHg to 38 kg/cm<sup>2</sup>)
  - 1/4" → 5/16" (2min → 2.5min)
  - No oil is used in pressure test of gauges.  
→ For prevention of contamination

- Temperature scale indicates the relationship between pressure and temperature in gas saturated state.
- Differences
  - Change in pressure
  - Change in service port diameter

### 7. Charge hose for R410A

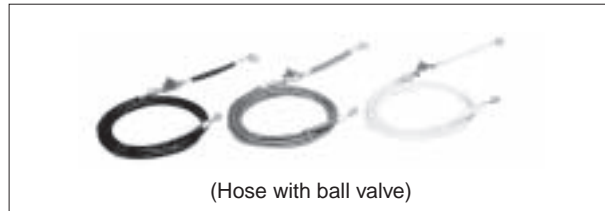

- Specifications
  - Working pressure 5.08 MPa (51.8 kg/cm<sup>2</sup>)
  - Rupture pressure 25.4 MPa (259 kg/cm<sup>2</sup>)
  - Available with and without hand-operate valve that prevents refrigerant from outflow.
- Differences
  - Pressure proof hose
  - Change in service port diameter
  - Use of nylon coated material for HFC resistance

### 8. Charging cylinder

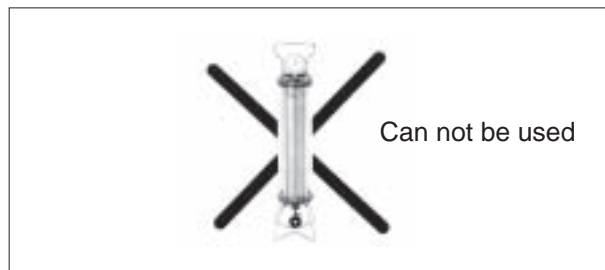

- Specifications
  - Use weigher for refrigerant charge listed below to charge directly from refrigerant cylinder.
- Differences
  - The cylinder can not be used for mixed refrigerant since mixing ratio is changed during charging.

When R410A is charged in liquid state using charging cylinder, foaming phenomenon is generated inside charging cylinder.



### 9. Weigher for refrigerant charge



#### ■ Specifications

- High accuracy  
TA101A (for 10-kg cylinder) =  $\pm 2$ g  
TA101B (for 20-kg cylinder) =  $\pm 5$ g
- Equipped with pressure-resistant sight glass to check liquid refrigerant charging.
- A manifold with separate ports for HFCs and previous refrigerants is equipped as standard accessories.

#### ■ Differences

- Measurement is based on weight to prevent change of mixing ratio during charging.

### 10. Charge mouthpiece



#### ■ Specifications

- For R410A, 1/4" → 5/16" (2min → 2.5min)
- Material is changed from CR to H-NBR.

#### ■ Differences

- Change of thread specification on hose connection side (For the R410A use)
- Change of sealer material for the HFCs use.

# Index

<b>A</b>		<b>E</b>	
A0 .....	173	E1 .....	188
A1 .....	174	E3 .....	189
A3 .....	175	E4 .....	190
A6 .....	177	E5 .....	191
A7 .....	178	E6 .....	192
A9 .....	180	E7 .....	193
AF .....	182	E9 .....	195
AJ .....	183	Electronic Expansion Valve PI Control .....	83
Abnormal Discharge Pipe Temperature .....	197	Emergency Operation .....	100
Abnormal Outdoor Fan Motor Signal .....	199	Error of External Protection Device .....	173
About Refrigerant R410A .....	318	Excessive Number of Indoor Units .....	230
Actuation of High Pressure Switch .....	189		
Actuation of Low Pressure Sensor .....	190	<b>F</b>	
Address Duplication of Central		F3 .....	197
Remote Controller .....	231	F6 .....	198
Address Duplication, Improper Setting .....	241, 248	Fan Motor (M1F) Lock, Overload .....	177
Applicable range of Field setting .....	123	Field Setting .....	119
Auto restart after power failure reset .....	124	Field Setting from Outdoor Unit .....	132
		Field Setting from Remote Controller .....	119
<b>B</b>		Filter Sign Setting .....	124
Basic Control .....	76	Freeze Prevention .....	108
		Functional Parts Layout .....	57
<b>C</b>		RXYQ14, 16M .....	59
C4 .....	184	RXYQ5M .....	57
C5 .....	185	RXYQ8, 10, 12M .....	58
C9 .....	186		
CJ .....	187	<b>H</b>	
Centralized Control Group No. Setting .....	128	H7 .....	199
Check No. 12 .....	256	H9 .....	200
Check No. 8 .....	255	Heating operation prohibition .....	102
Check No. 9 .....	255	High Pressure Protection Control .....	94
Check Operation .....	115		
Check Operation not executed .....	221	<b>I</b>	
Compressor Motor Lock .....	191	Improper Combination of Optional Controllers for	
Compressor Motor Overcurrent/Lock .....	192	Centralized Control .....	239, 246
Compressor PI Control .....	77	Inverter Compressor Abnormal .....	210
Contents of Control Modes .....	130	Inverter Current Abnormal .....	211
Cool/Heat Mode Switching .....	142	Inverter Over-Ripple Protection .....	215
Cooling Operation Fan Control .....	84	Inverter Protection Control .....	97
Current Sensor Malfunction .....	201	Inverter Start up Error .....	212
<b>D</b>		<b>J</b>	
Defrosting Operation .....	88	J2 .....	201
Demand Operation .....	102	J3 .....	202
Detailed Explanation of Setting Modes .....	124	J5 .....	203
Discharge Pipe Protection Control .....	96	J6 .....	204
Display "Under Host Computer Integrate Control"		J8 .....	205
Blinks (Repeats Double Blink) .....	254	J9 .....	206
Display "Under Host Computer Integrate Control"		JA .....	207
Blinks (Repeats Single Blink) .....	251	JC .....	208
Drain Level above Limit .....	182		
Drain Pump Control .....	103	<b>L</b>	
		L4 .....	209
		L5 .....	210

L8 .....	211	Malfunction of Transmission Between Indoor and Outdoor Units in the Same System .....	228
L9 .....	212	Malfunction of Transmission Between Inverter and Control PC Board .....	213
LC .....	213	Malfunction of Transmission Between Master and Slave Remote Controllers .....	227
List of Electrical and Functional Parts .....	293	Malfunction of Transmission Between Optional Controllers for Centralized Control .....	238, 245
Indoor Unit .....	295	Malfunction of Transmission Between Outdoor Units .....	225
Outdoor Unit .....	293	Malfunction of Transmission Between Remote Controller and Indoor Unit .....	224
Louver Control for Preventing Ceiling Dirt .....	105	Method of Replacing The Inverter's Power Transistors and Diode Modules .....	314
Low Pressure Drop Due to Refrigerant Shortage or Electronic Expansion Valve Failure .....	217	O	
Low Pressure Protection Control .....	95	Oil Return Operation .....	86
M		Operation Lamp Blinks .....	249
M1 .....	237, 244	Operation Mode .....	75
M8 .....	238, 245	Operation When Power is Turned On .....	117
MA .....	239, 246	Option List .....	301
MC .....	241, 248	Other Control .....	99
Malfunction code indication by outdoor unit PCB .....	171	Outdoor Air Processing Unit-Field Setting .....	127
Malfunction of Capacity Determination Device .....	183	Outdoor Unit PC Board Layout .....	118
Malfunction of Discharge Pipe Pressure Sensor .....	207	Outdoor Unit Rotation .....	99
Malfunction of Discharge Pipe Thermistor (R3, R31~33T) .....	202	P	
Malfunction of Drain Level Control System (S1L) .....	175	P1 .....	215
Malfunction of Inverter Radiating Fin Temperature Rise .....	209	P4 .....	216
Malfunction of Inverter Radiating Fin Temperature Rise Sensor .....	216	PC Board Defect .....	174, 188, 237, 244
Malfunction of Moving Part of Electronic Expansion Valve (20E) .....	180	Piping Installation Point .....	304
Malfunction of Moving Part of Electronic Expansion Valve (Y1E, Y2E) .....	195	The Example of A Wrong Pattern .....	305
Malfunction of Oil Equalizing Pipe Thermistor (R7T) .....	205	Power Supply Insufficient or Instantaneous Failure .....	219
Malfunction of Outdoor Unit Fan Motor .....	193	Precautions for New Refrigerant (R410) .....	318
Malfunction of Receiver Gas Pipe Thermistor (R5T) .....	206	Pressure Equalization prior to Startup .....	93
Malfunction of Suction Pipe Pressure Sensor .....	208	Pressure Sensor .....	313
Malfunction of Swing Flap Motor (MA) .....	178	Procedure and Outline .....	114
Malfunction of System, Refrigerant System Address Undefined .....	235	Protection Control .....	94
Malfunction of Thermistor (R1T) for Suction Air .....	186	Pump-down Residual Operation .....	89
Malfunction of Thermistor (R2T) for Heat Exchanger .....	184	R	
Malfunction of Thermistor (R2T) for Suction Pipe .....	203	Refrigerant Circuit .....	50
Malfunction of Thermistor (R3T) for Gas Pipes .....	185	FXMQ125~250MFV1 .....	56
Malfunction of Thermistor (R4T) for Outdoor Unit Heat Exchanger .....	204	RXYQ14, 16M .....	54
Malfunction of Thermistor for Outdoor Air (R1T) .....	200	RXYQ5M .....	50
Malfunction of Thermostat Sensor in Remote Controller .....	187	RXYQ8, 10, 12M .....	52
Malfunction of Transmission Between Central Remote Controller and Indoor Unit .....	232, 236, 242	Refrigerant Cylinders .....	320
Malfunction of Transmission Between Indoor Units .....	222	Refrigerant Flow for Each Operation Mode .....	60
		RXYQ14, 16M .....	68
		RXYQ5M .....	60
		RXYQ8, 10, 12M .....	64
		Refrigerant Overcharged .....	198
		Refrigerant System not Set, Incompatible Wiring/Piping .....	234
		Replacement procedure for INV compressor, VRV II (RXYQ5M-48M) .....	258
		Restart Standby .....	90
		Reverse Phase, Open Phase .....	218

## S

STD Compressor Overload Protection .....	98
Selection of Pipe Size, Joints and Header .....	306
Service Tools .....	321
Setting Contents and Code No. ....	122
Setting by dip switches .....	132
Setting by pushbutton switches .....	134
Setting of Low Noise Operation and Demand Operation .....	147
Setting of Refrigerant Additional Charging Operation .....	153
Special Control .....	85
Specifications .....	10
Indoor Units .....	21
Outdoor Units .....	10
Startup Control .....	85
Stopping Operation .....	91

## T

Test Operation .....	114
Thermistor Resistance / Temperature Characteristics .....	311
Thermostat Sensor in Remote Controller .....	106
Troubleshooting (OP Central Remote Controller) .....	236
Schedule Timer) .....	242
Unified ON/OFF Controller) .....	249

## U

U0 .....	217
U1 .....	218
U2 .....	219
U3 .....	221
U4 .....	222
U5 .....	224
U7 .....	225
U8 .....	227
U9 .....	228
UA .....	230
UC .....	231
UE .....	232, 236, 242
UF .....	234
UH .....	235



# Drawings & Flow Charts

<b>A</b>	
Abnormal Discharge Pipe Temperature .....	197
Abnormal Outdoor Fan Motor Signal .....	199
Actuation of High Pressure Switch .....	189
Actuation of Low Pressure Sensor .....	190
Address Duplication of Central Remote Controller .....	231
Address Duplication, Improper Setting .....	241, 248
<b>C</b>	
Centralized Control Group No. Setting	
BRC1A Type .....	128
BRC7C Type .....	129
Group No. Setting Example .....	129
Charge hose for R410A .....	325
Charge mouthpiece .....	326
Charging cylinder .....	325
Check No. 12 .....	256
Check No. 8 .....	255
Check No. 9 .....	255
Check Operation not executed .....	221
Compressor Motor Lock .....	191
Compressor Motor Overcurrent/Lock .....	192
Contents of Control Modes	
How to Select Operation Mode .....	131
Current Sensor Malfunction .....	201
<b>D</b>	
Discharge air temperature control	
Cooling operations .....	110
Heating operations .....	111
Display "Under Host Computer Integrate Control"	
Blinks (Repeats Double Blink) .....	254
Display "Under Host Computer Integrate Control"	
Blinks (Repeats Single Blink) .....	251
Display of sensor and address data .....	167
Drain Level above Limit .....	182
Drain Pump Control	
When the Float Switch is Tripped and "AF" is Displayed on the Remote Controller .....	104
When the Float Switch is Tripped During Cooling OFF by Thermostat .....	103
When the Float Switch is Tripped During Heating Operation .....	104
When the Float Switch is Tripped While the Cooling Thermostat is ON .....	103
<b>E</b>	
Error of External Protection Device .....	173
Excessive Number of Indoor Units .....	230
<b>F</b>	
Fan Motor (M1F) Lock, Overload .....	177
Field Setting From Outdoor Unit	
Mode changing procedure .....	134
Setting by pushbutton switches .....	134
Field Setting from Outdoor Unit	
Setting by dip switches .....	132
Flaring tool .....	322
Forced fan ON .....	167
Freeze Prevention .....	108
Functional Parts Layout .....	57
RXYQ14, 16M .....	59
RXYQ5M .....	57
RXYQ8, 10, 12M .....	58
<b>G</b>	
Gauge manifold for R410A .....	324
<b>H</b>	
How to Enter the Service Mode .....	166
<b>I</b>	
Improper Combination of Optional Controllers for Centralized Control .....	239, 246
Individual setting .....	167
Inverter Compressor Abnormal .....	210
Inverter Current Abnormal .....	211
Inverter Over-Ripple Protection .....	215
Inverter Start up Error .....	212
<b>L</b>	
Leak tester .....	324
Low Pressure Drop Due to Refrigerant Shortage or Electronic Expansion Valve Failure .....	217
<b>M</b>	
Malfunction hysteresis display .....	167
Malfunction of Capacity Determination Device ...	183
Malfunction of Discharge Pipe	
Pressure Sensor .....	207
Malfunction of Discharge Pipe Thermistor (R3, R31~33T) .....	202
Malfunction of Drain Level Control System (S1L) .....	175
Malfunction of Inverter Radiating Fin Temperature Rise .....	209
Malfunction of Inverter Radiating Fin Temperature Rise Sensor .....	216
Malfunction of Moving Part of Electronic Expansion Valve (20E) .....	180
Malfunction of Moving Part of Electronic Expansion Valve (Y1E, Y2E) .....	195
Malfunction of Oil Equalizing Pipe Thermistor (R7T) .....	205
Malfunction of Outdoor Unit Fan Motor .....	193
Malfunction of Receiver Gas Pipe Thermistor (R5T) .....	206

Malfunction of Suction Pipe Pressure Sensor .....	208	RXYQ8, 10, 12M .....	52
Malfunction of Swing Flap Motor (MA) .....	178	Refrigerant Cylinders .....	320
Malfunction of System, Refrigerant		Refrigerant Flow for Each Operation Mode .....	60
System Address Undefined .....	235	RXYQ14, 16M .....	68
Malfunction of Thermistor (R1T)		RXYQ5M .....	60
for Suction Air .....	186	RXYQ8, 10, 12M .....	64
Malfunction of Thermistor (R2T)		Refrigerant oil (Air compal) .....	324
for Heat Exchanger .....	184	Refrigerant Overcharged .....	198
Malfunction of Thermistor (R2T)		Refrigerant R410A .....	318
for Suction Pipe .....	203	Refrigerant System not Set, Incompatible	
Malfunction of Thermistor (R3T)		Wiring/Piping .....	234
for Gas Pipes .....	185	Replacement procedure for INV compressor,	
Malfunction of Thermistor (R4T)		VRV II (RXYQ5M-48M) .....	258
for Outdoor Unit Heat Exchanger .....	204	Reverse Phase, Open Phase .....	218
Malfunction of Thermistor for			
Outdoor Air (R1T) .....	200	S	
Malfunction of Thermostat Sensor in Remote		Selection of Operation Mode .....	109
Controller .....	187	Setting of Air Flow Direction	
Malfunction of Transmission Between		Adjustment Range .....	126
Central Remote Controller and		Setting of Demand Operation	
Indoor Unit .....	232, 236, 242	Image of operation in the case of A .....	150
Malfunction of Transmission Between Indoor		Image of operation in the case of A and B ....	150
and Outdoor Units in the Same System .....	228	Image of operation in the case of B .....	150
Malfunction of Transmission		Setting of Low Noise Operation	
Between Indoor Units .....	222	Image of operation in the case of A .....	148
Malfunction of Transmission Between Inverter		Image of operation in the case of A, B .....	148
and Control PC Board .....	213	Image of operation in the case of B .....	148
Malfunction of Transmission Between Master		Simplified Remote Controller .....	121
and Slave Remote Controllers .....	227	BRC2A51 .....	121
Malfunction of Transmission Between Optional		T	
Controllers for Centralized Control .....	238, 245	Test Operation .....	115
Malfunction of Transmission Between		Thermostat Sensor in Remote Controller	
Outdoor Units .....	225	Cooling .....	106
Malfunction of Transmission Between Remote		Heating .....	107
Controller and Indoor Unit .....	224	Torque wrench .....	323
Method of Replacing The Inverter's		Troubleshooting (OP	
Power Transistors and Diode Modules .....	314	Central Remote Controller) .....	236
Diode Module .....	315	Schedule Timer) .....	242
Power Transistor IGBT		Unified ON/OFF Controller) .....	249
(On Inverter PC Board) .....	315		
O		U	
Operation Lamp Blinks .....	249	Unit No. transfer .....	167
Outdoor Unit PC Board Layout .....	118	V	
P		Vacuum pump with check valve .....	323
PC Board Defect .....	174, 188, 237, 244	W	
Piping Diagrams .....	260	Weigher for refrigerant charge .....	326
Indoor Unit .....	263	Wired Remote Controller .....	119
Outdoor Unit .....	260	Wireless Remote Controller - Indoor Unit .....	120
Piping Installation Point .....	304	BRC7C type .....	120
The Example of A Wrong Pattern .....	305	Wiring Diagrams for Reference .....	269
Power Supply Insufficient or		Field Wiring .....	272
Instantaneous Failure .....	219	Indoor Unit .....	275
Pressure Sensor .....	313	Outdoor Unit .....	269
R			
Refrigerant Circuit .....	50		
FXMQ125~250MFV1 .....	56		
RXYQ14, 16M .....	54		
RXYQ5M .....	50		



Daikin Europe N.V. is approved by LRQA for its Quality Management System in accordance with the ISO9001 standard. ISO9001 pertains to quality assurance regarding design, development, manufacturing as well as to services related to the product.



Daikin units comply with the European regulations that guarantee the safety of the product.



ISO14001 assures an effective environmental management system in order to help protect human health and the environment from the potential impact of our activities, products and services and to assist in maintaining and improving the quality of the environment.

VRV products are not within the scope of the Eurovent certification programme.

Specifications are subject to change without prior notice



**DAIKIN EUROPE N.V.**

Zandvoordestraat 300  
B-8400 Ostend - Belgium  
www.daikineurope.com